

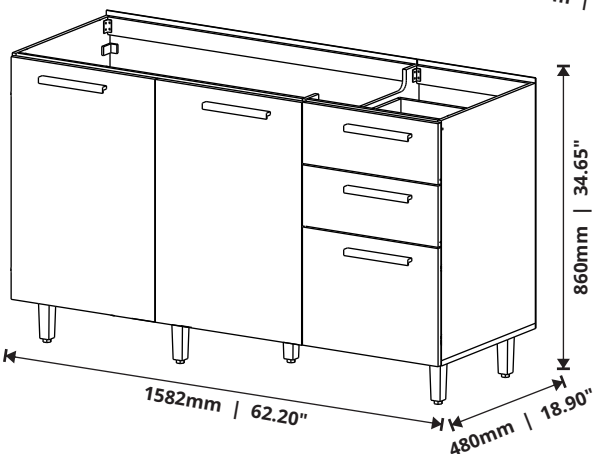

VITAMOV

BALCÃO ELOA 1.58 ELOA1.58 COUNTER ENCIMERA ELOA1.58

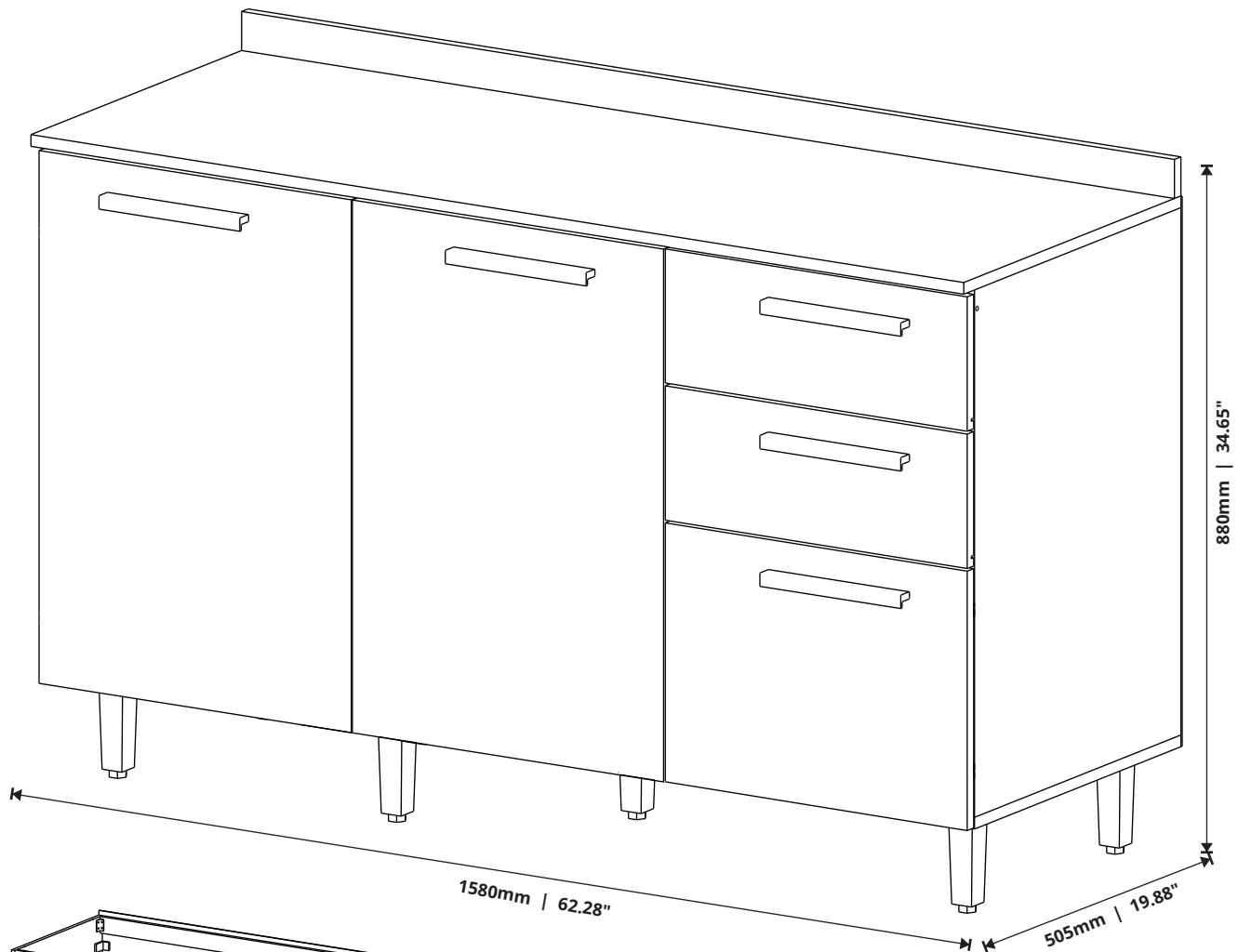

Opção sem tampo
Option without the top
Opción sin tapa

Rua Augusto Zanforlim, 1-25 - Distrito Industrial
CEP: 15520-000, Valentim Gentil/SP - Cx. Postal 18
Fone: (17) 3485-1336
vitamov@vitamov.com.br

ACESSÓRIOS

ACCESSORIES - ACCESORIOS

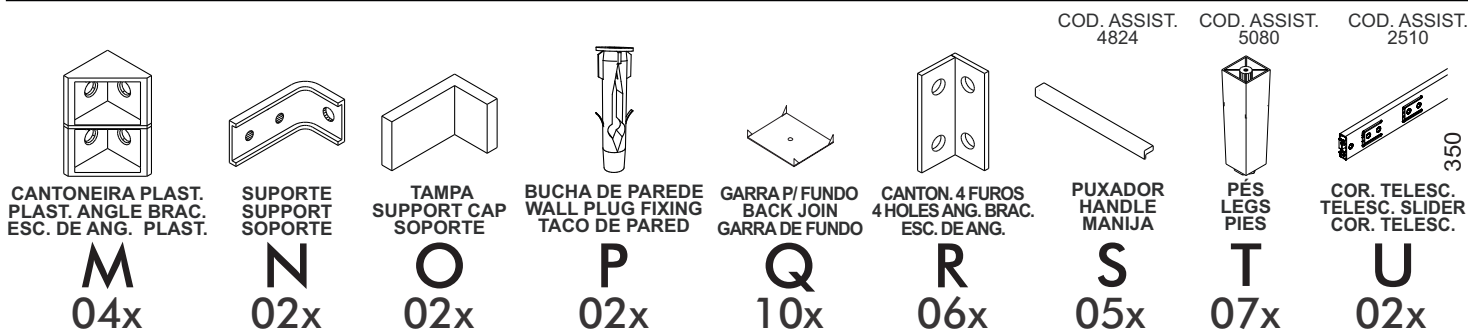
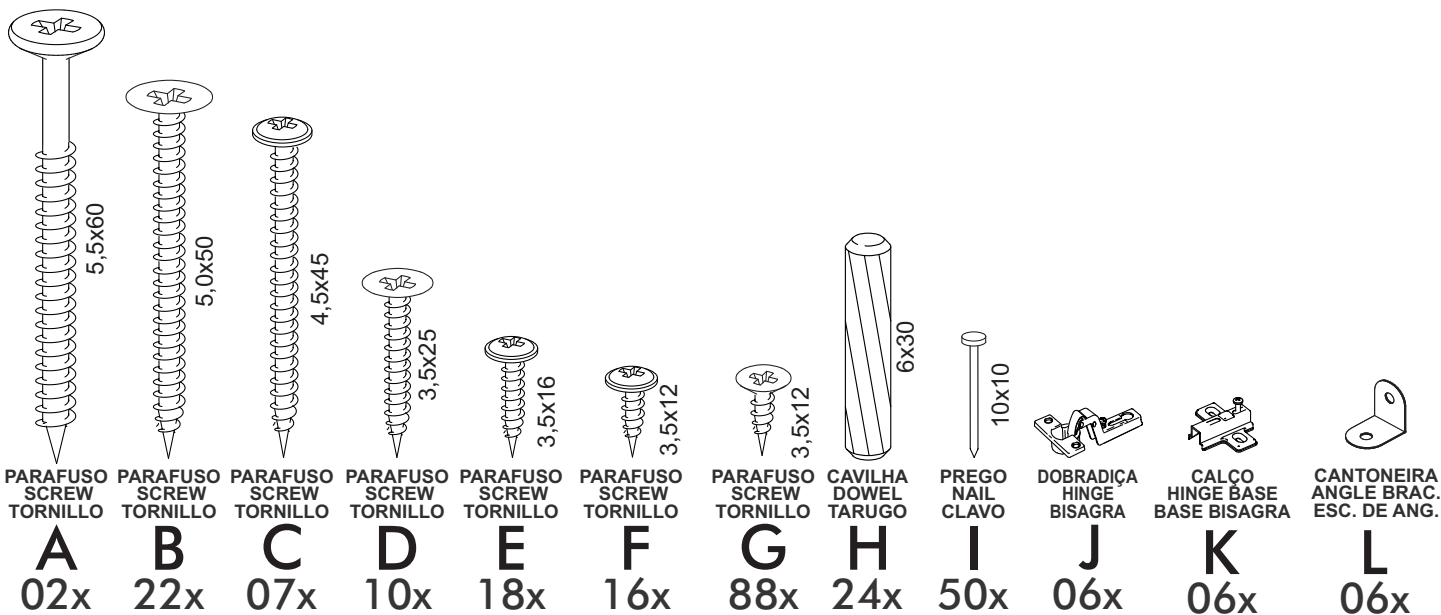

CAPACIDADE DE CARGA

LOAD CAPACITY - CAPACIDAD DE CARGA

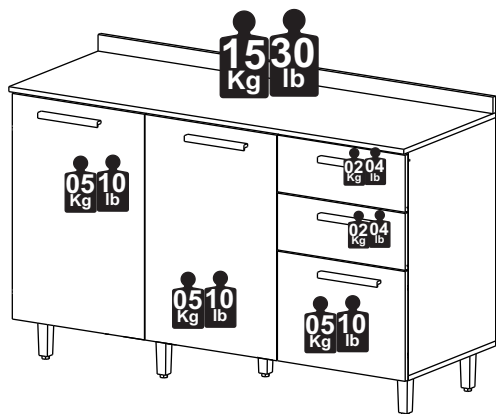

A CAPACIDADE DE CARGA INDICADA É DISTRIBUÍDA NAS ÁREAS DEMONSTRADAS.

THE INDICATED LOAD CAPACITY IS DISTRIBUTED IN THE SHOWN AREAS.
LA CAPACIDAD DE CARGA INDICADA ES DISTRIBUIDA EN ZONAS DEMONSTRADAS.

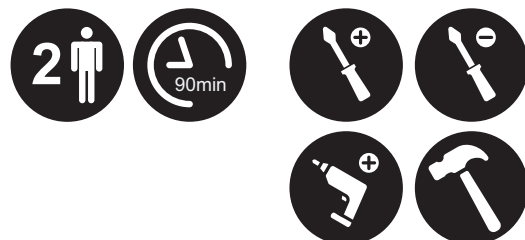

AS FERRAMENTAS NECESSÁRIAS PARA A MONTAGEM DO PRODUTO NÃO SÃO FORNECIDAS PELA EMPRESA.
THE TOOLS NEEDED FOR THE PRODUCT ASSEMBLY ARE NOT PROVIDED BY THE COMPANY.
LAS HERRAMIENTAS NECESARIAS PARA LA EL MONTAJE DEL PRODUCTO NO SON PROPORCIONADO POR LA EMPRESA.

CERTIFICADO DE GARANTIA

CERTIFICATE OF WARRANTY - CERTIFICADO DE GARANTÍA

DISPOSIÇÕES

O projeto, instalação e a montagem na residência do consumidor não é responsabilidade da Vitamov. A montagem deve seguir corretamente as instruções que se encontram dentro da embalagem de cada módulo.

A Vitamov se reserva o direito de efetuar modificações de caráter técnico em seus produtos, sem aviso prévio.

EXCLUSÃO DA GARANTIA

O presente termo exclui de sua garantia:

- danos causados em consequência de acidentes, mau uso, manuseio ou deslocamento incorreto dos produtos;
- danos causados por montagem inadequada;
- danos em decorrência de agentes externos (inundações, incêndio, etc);
- defeitos oriundos de umidade excessiva

A fixação dos armários de forma segura e garantida depende da qualidade da parede na qual os mesmos serão instalados.

A Vitamov não se responsabiliza por danos causados por instalações dos armários em paredes inadequadas.

PROVISIONS

The design, installation and assembly in the consumer's home is not the responsibility of Vitamov. Assembly must correctly follow the instructions given found inside the packaging of each module. Vitamov reserves the right to make technical changes to its products without prior notice.

EXCLUSION OF WARRANTY

This term excludes from its warranty:

- damage caused as a result of accidents, misuse, incorrect handling or displacement of the products;
- damage caused by improper assembly;
- damage resulting from external agents (floods, fire, etc.);
- defects from excessive humidity. Fixing the cabinets safely and securely depends on the quality of the wall on which they will be installed. Vitamov is not responsible for damage caused by installing cabinets on inadequate walls.

PROVISIONES

El diseño, instalación y montaje en el domicilio del consumidor no es responsabilidad de Vitamov. El montaje debe seguir correctamente las instrucciones dadas que se encuentra dentro del embalaje de cada módulo. Vitamov se reserva el derecho de realizar cambios técnicos en sus productos sin previo aviso.

EXCLUSIÓN DE GARANTÍA

Este certificado excluye de su garantía:

- daños causados como consecuencia de accidentes, mal uso, manejo incorrecto o desplazamiento de los productos;
- daños causados por un montaje inadecuado;
- daños resultantes de agentes externos (inundaciones, incendios, etc.);
- defectos por exceso de humedad. La fijación de los gabinetes de manera segura y segura depende de la calidad de la pared en la que se instalarán.

Vitamov no es responsable de daños causados por instalar gabinetes en paredes inadecuadas.

PEÇAS

PIECES - PIEZAS

Nº PÇ	PORTUGUÊS	ENGLISH	ESPAÑOL	Medidas/Measures/ Medidas	Qtde.	Cod. Assist.
1	Base	Base	Base	1582 x 480 x 15	1	5031
2	Lateral Direita	Right Side	Lado Derecho	675 x 480 x 12	1	5029
3	Lateral Esquerda	Left Side	Lado Izquierdo	675 x 480 x 12	1	5033
4	Divisória	Partición	Partición	675 x 480 x 12	1	5034
5	Prateleira	Shelf	Repisa	1033 x 306 x 12	1	5043
6	Travessa Traseira Maior	Larger Back Frame	Moldura Trasera Mayor	1033 x 50 x 12	1	5035
7	Batente Dianteiro Maior	Larger Back Stop	Tope Delantero Mayor	1033 x 50 x 12	1	5036
8	Travessa Traseira Menor	Smaller Back Frame	Moldura Trasera Menor	511 x 50 x 12	1	5038
9	Batente Dianteiro Menor	Smaller Back Stop	Tope Delantero Menor	511 x 50 x 12	1	5030
10	Pontalete	Frame	Moldura	332 x 70 x 12	1	5037
11	Porta Esquerda Maior	Larger Left Door	Puerta Izquierda Mayor	682 x 523 x 15	1	5028
12	Porta Direita Maior	Larger Right Door	Puerta Derecha Mayor	682 x 523 x 15	1	5028
13	Porta Menor	Smaller Door	Puerta Menor	523 x 332 x 15	1	5039
14	Frente de Gaveta	Drawer Front	Frente De Cajón	523 x 172 x 15	2	5032
15	Lateral De Gaveta	Drawer Side	Lado De Cajón	350 x 100 x 12	4	5041
16	Contra Fundo de Gaveta	Counter Bottom	Contrafondo De Cajón	487 x 100 x 12	2	5040
17	Fundo 1	Back Panel 1	Fondo 1	1050 x 352 x 03	2	5138
18	Fundo 2	Back Panel 2	Fondo 2	704 x 528 x 03	1	5044
19	Fundo de Gaveta	Drawer Back	Fondo De Cajón	485 x 366 x 03	2	5045
20	Tampo do Balcão (Opcional)	Counter Top (Optional)	Tapa Encimera (Optional)	1580 x 505 x 15	1	5026
21	Régua do Tampo (Opcional)	Top Frame (Optional)	Moldura Encimera (Optional)	1580 x 50 x 15	1	5027

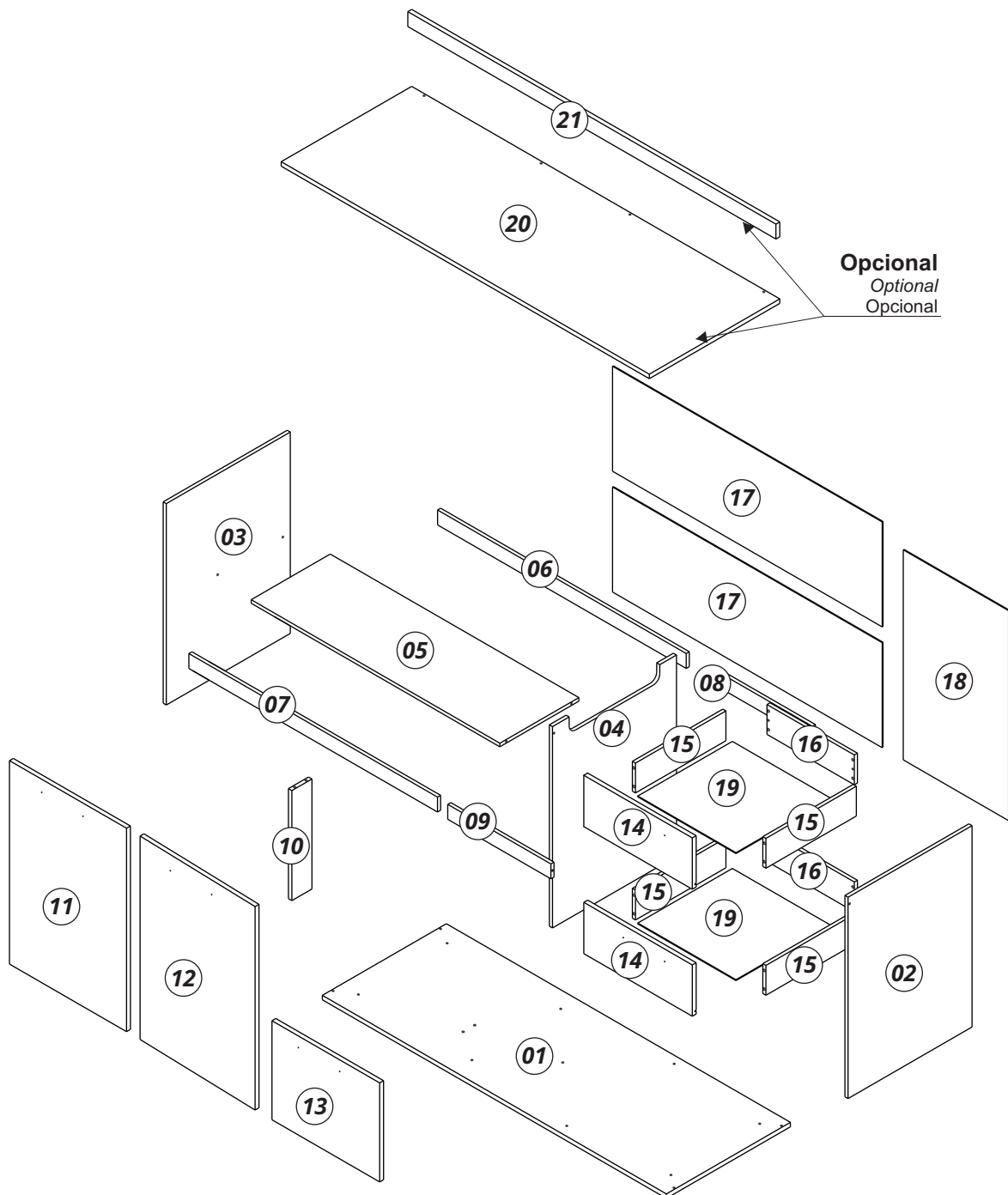

PRÉ-MONTAGEM

PRE ASSEMBLY - PRÉ-MONTAJE

IMPORTANT ATTENTION - IMPORTANTE
 A MONTAGEM DEVE SER REALIZADA POR UM PROFISSIONAL DE MONTAGEM.
 ASSEMBLY MUST BE CARRIED OUT BY AN ASSEMBLY PROFESSIONAL.
 EL MONTAJE DEBE SER HECHO POR UN MONTADOR DE MUEBLES.

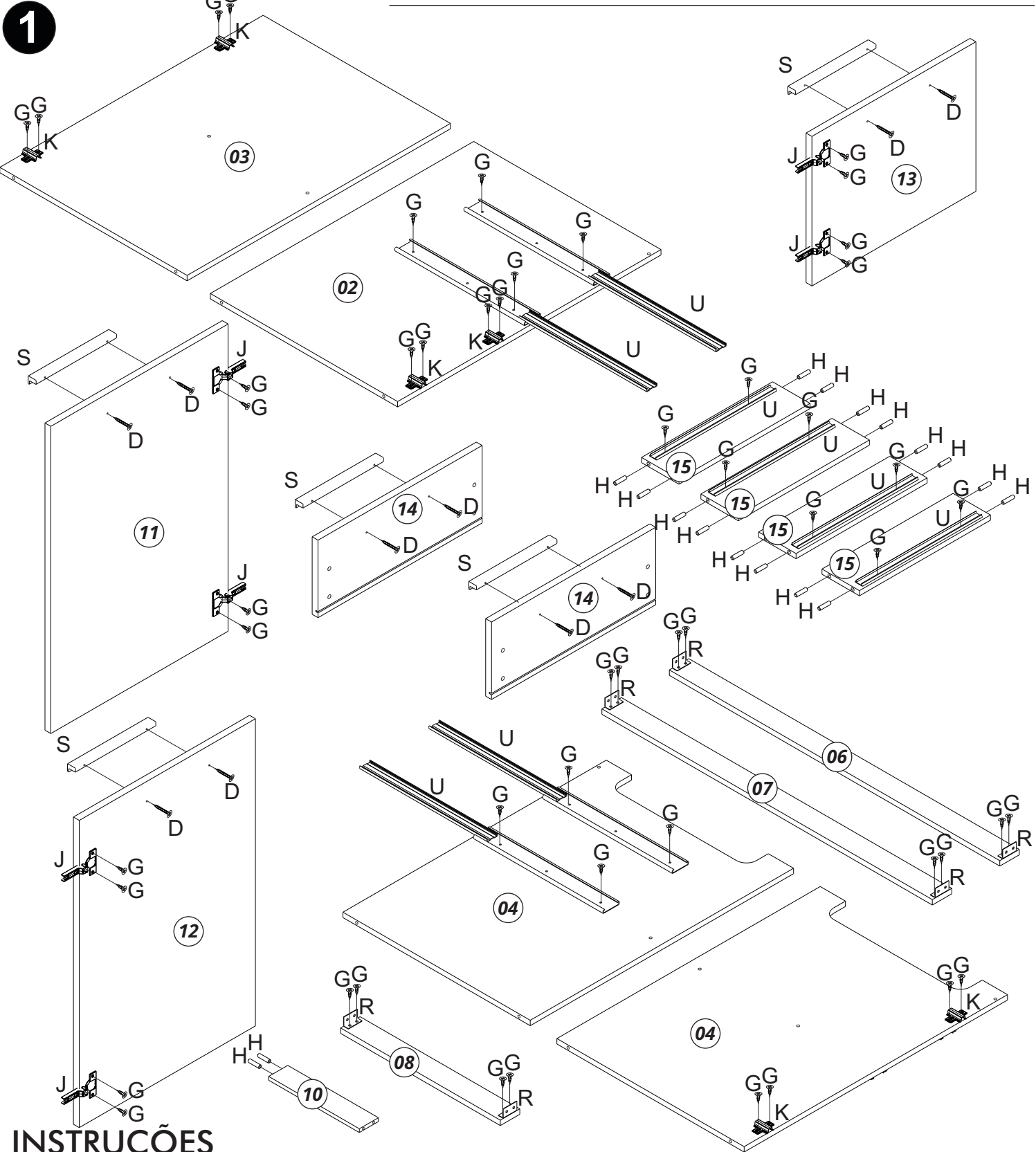

INSTRUÇÕES

INSTRUCTIONS - INSTRUCCIONES

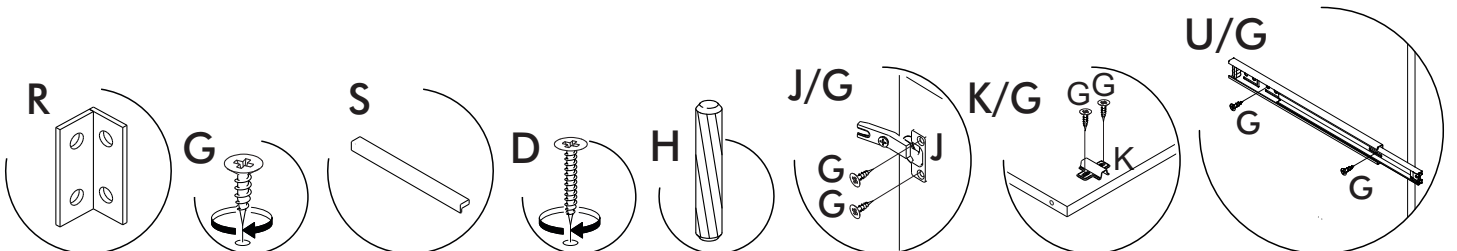

MONTAGEM

ASSEMBLY - MONTAJE

1

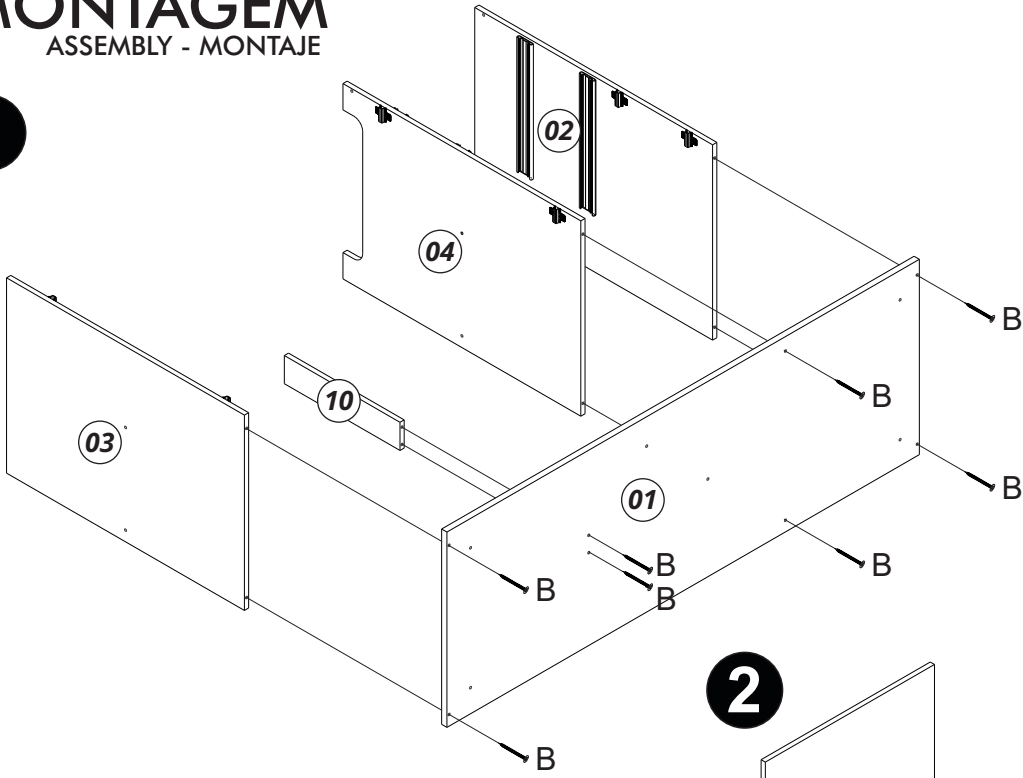

2

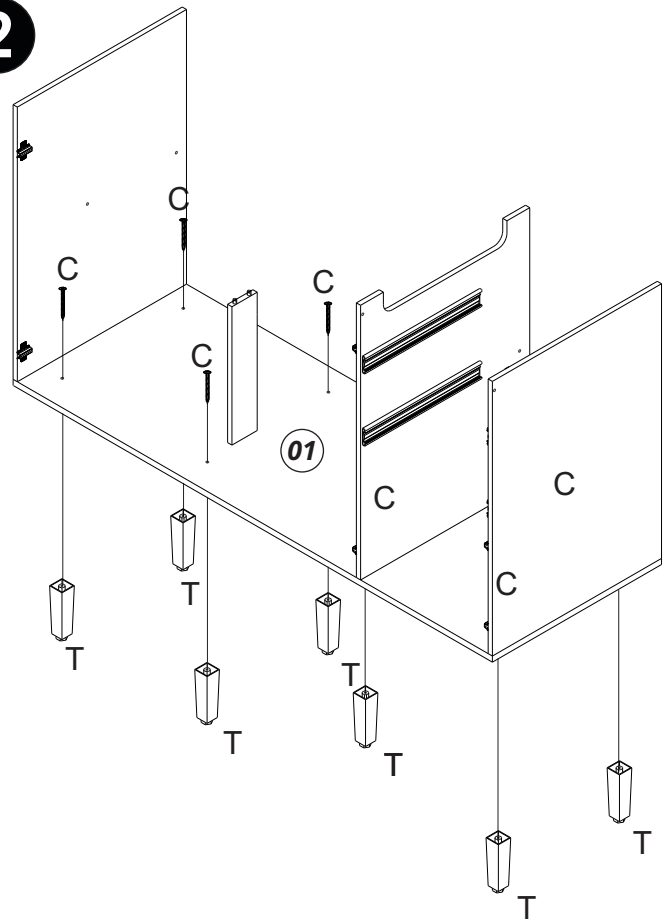

3

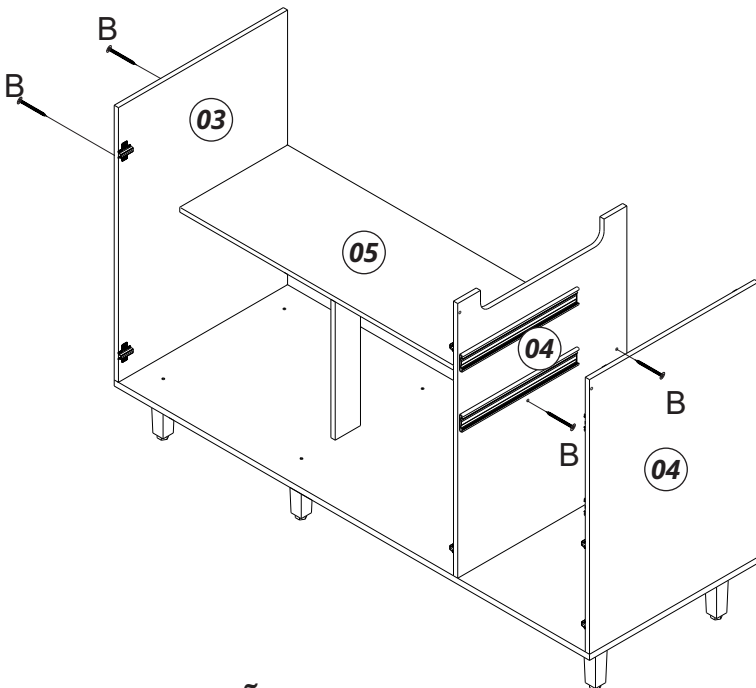

INSTRUÇÕES

INSTRUCTIONS - INSTRUCCIONES

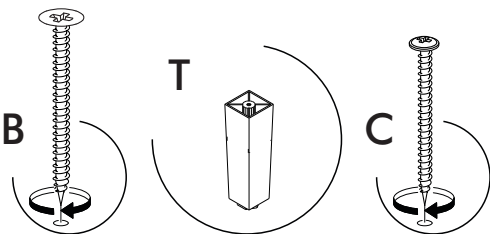

MONTAGEM

ASSEMBLY - MONTAJE

4

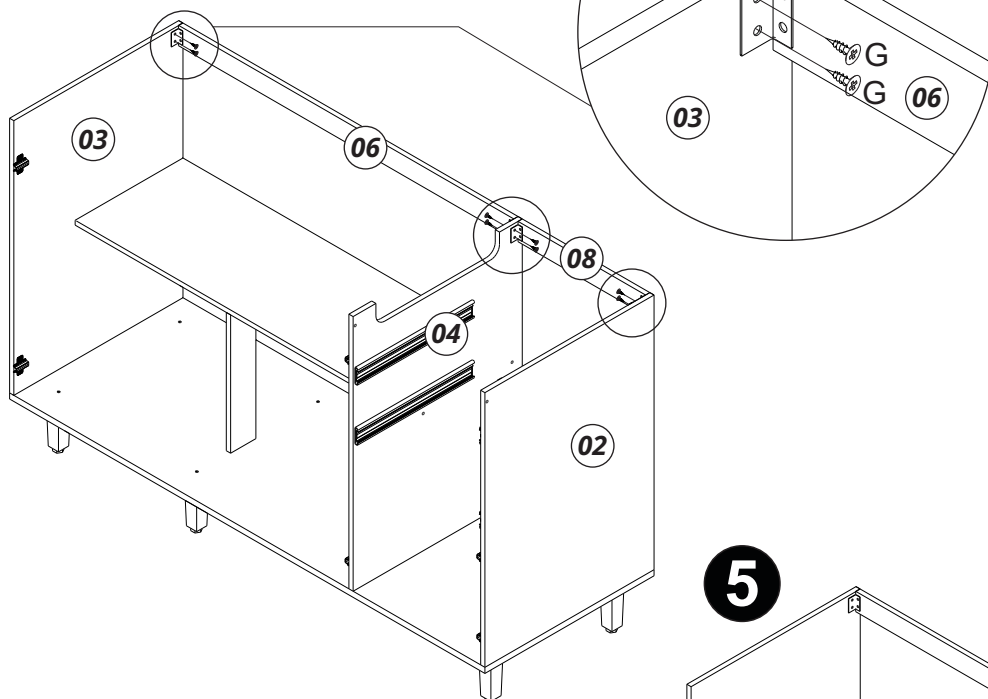

5

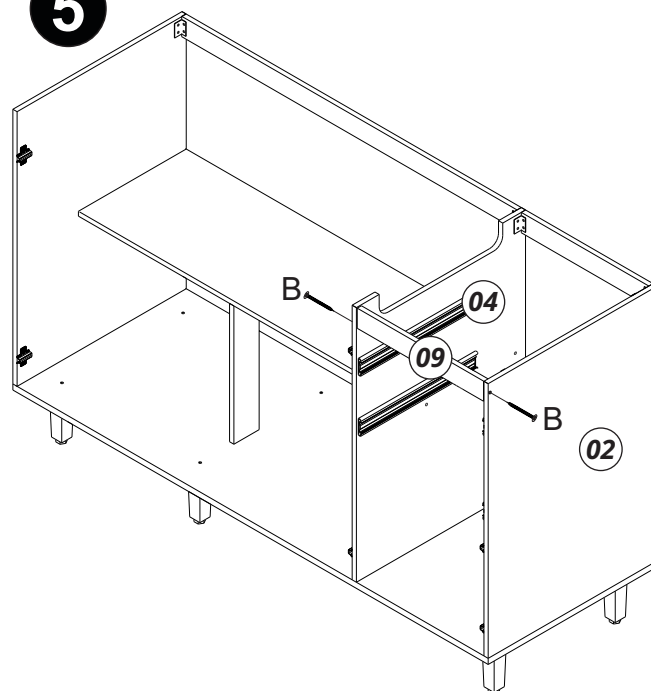

6

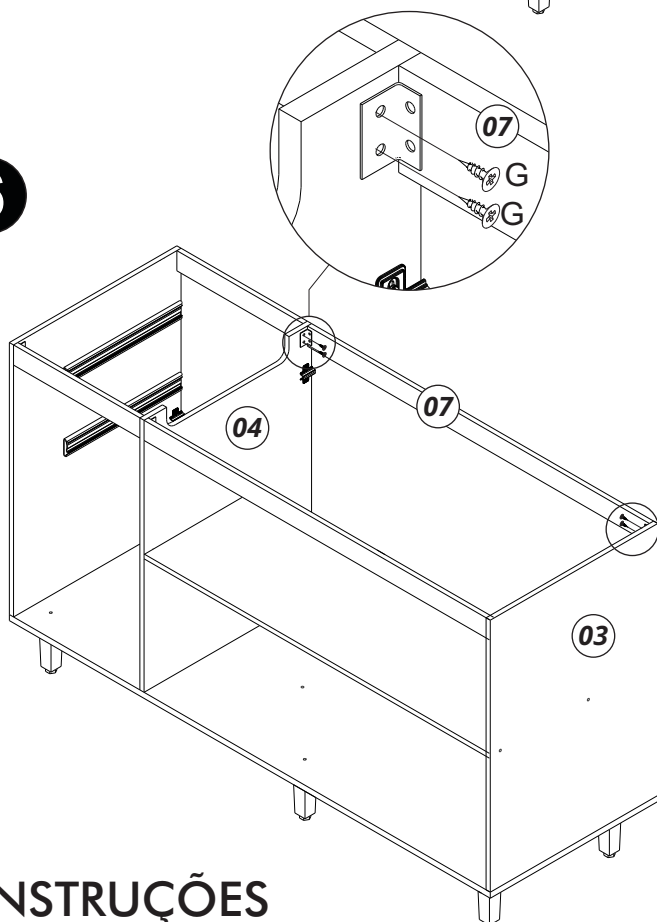

INSTRUÇÕES

INSTRUCTIONS - INSTRUCCIONES

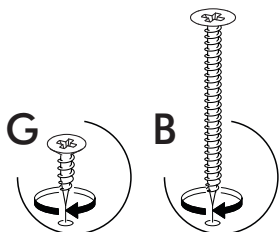

MONTAGEM

ASSEMBLY - MONTAJE

7

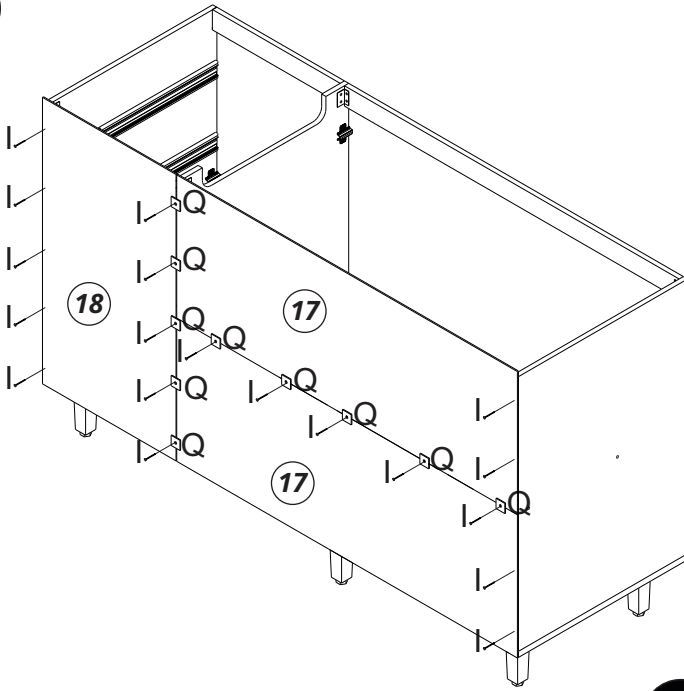

8 2x

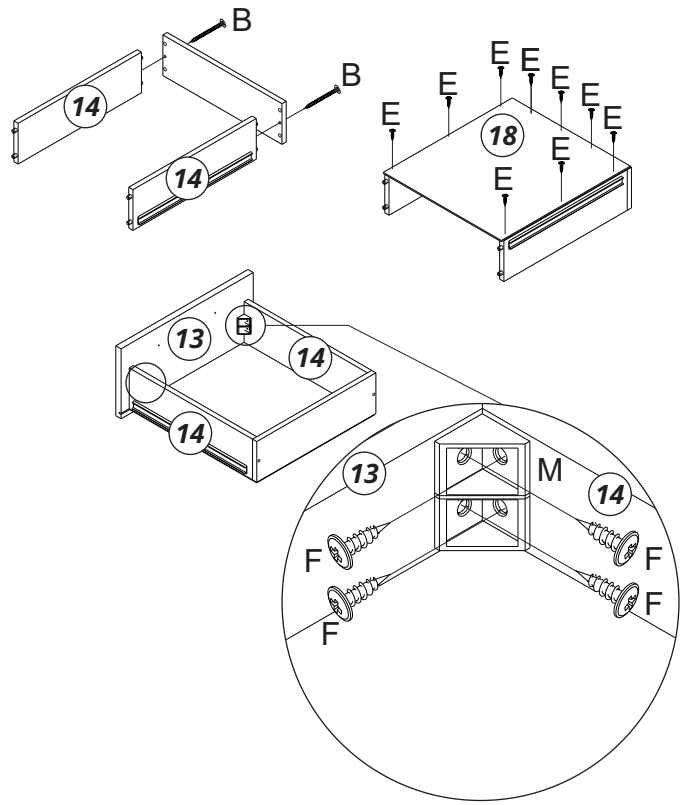

9

Tampo Opcional
Optional Top
Tapa Opcional

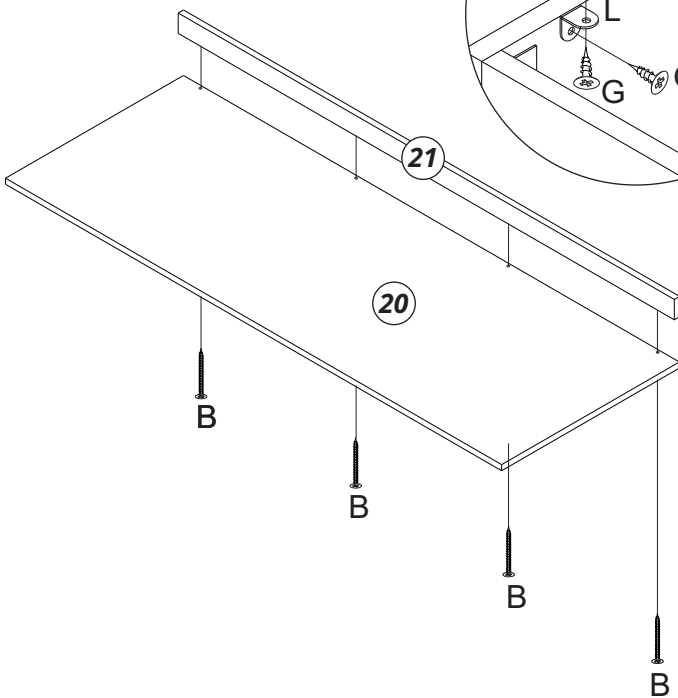

10

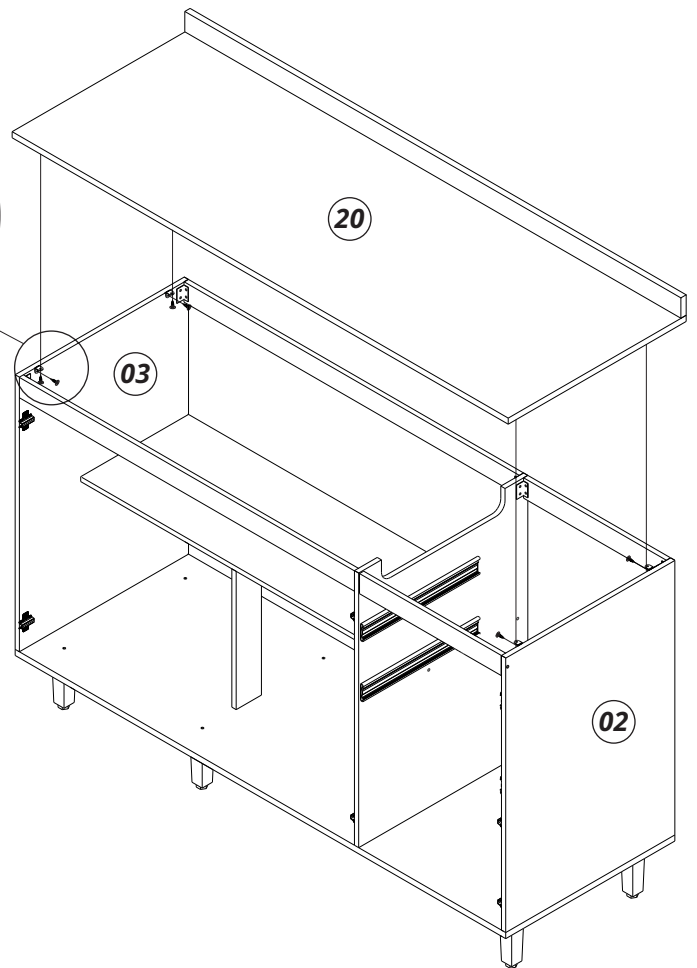
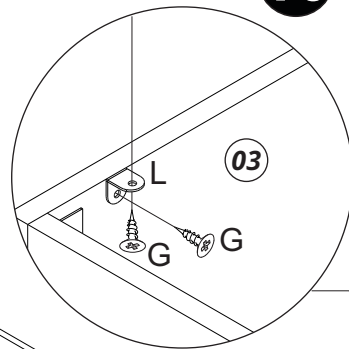

INSTRUÇÕES

INSTRUCTIONS - INSTRUCCIONES

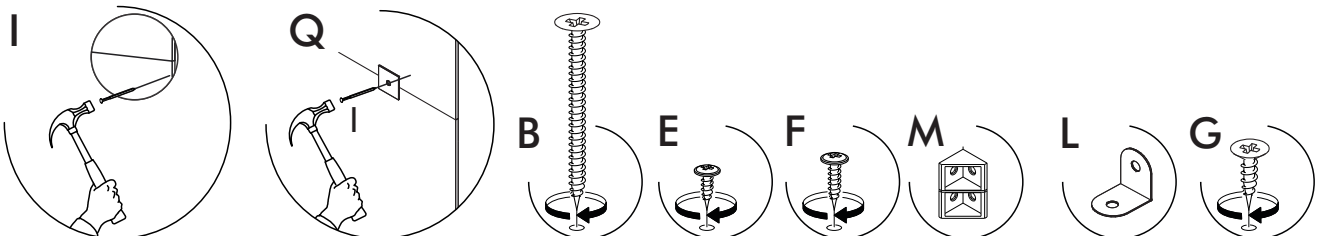

MONTAGEM

ASSEMBLY - MONTAJE

11

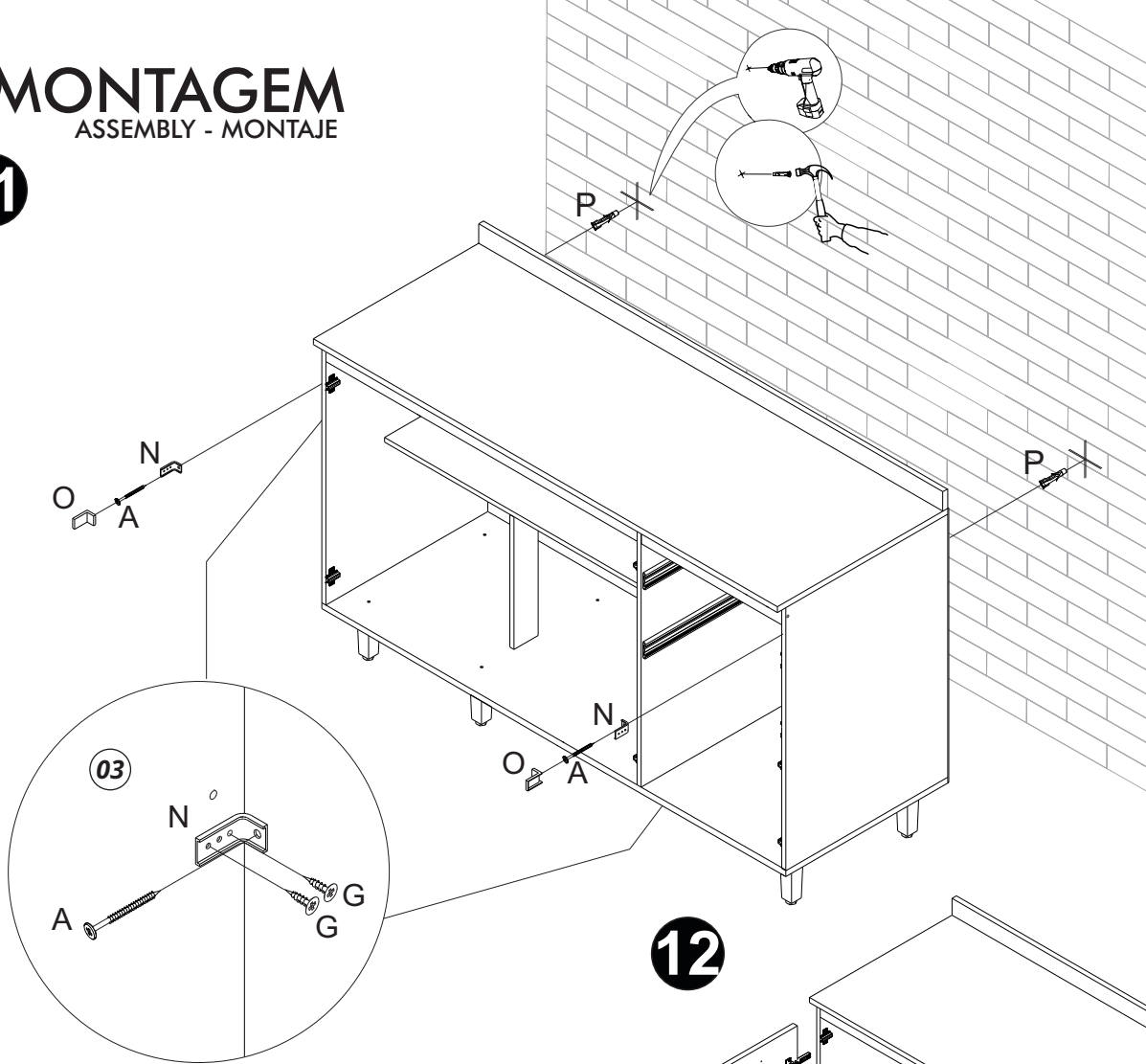

12

13

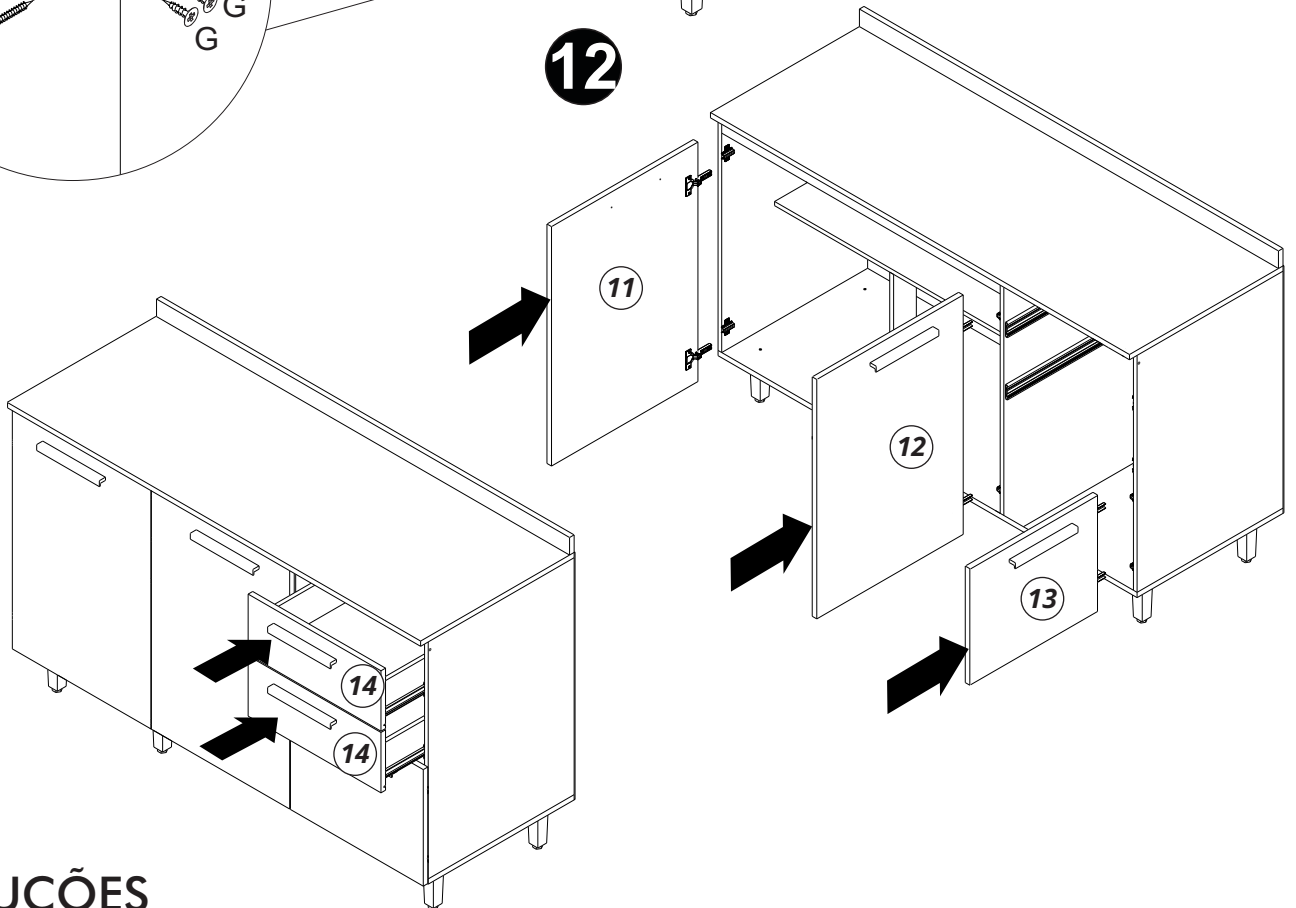

INSTRUÇÕES

INSTRUCTIONS - INSTRUCCIONES

