

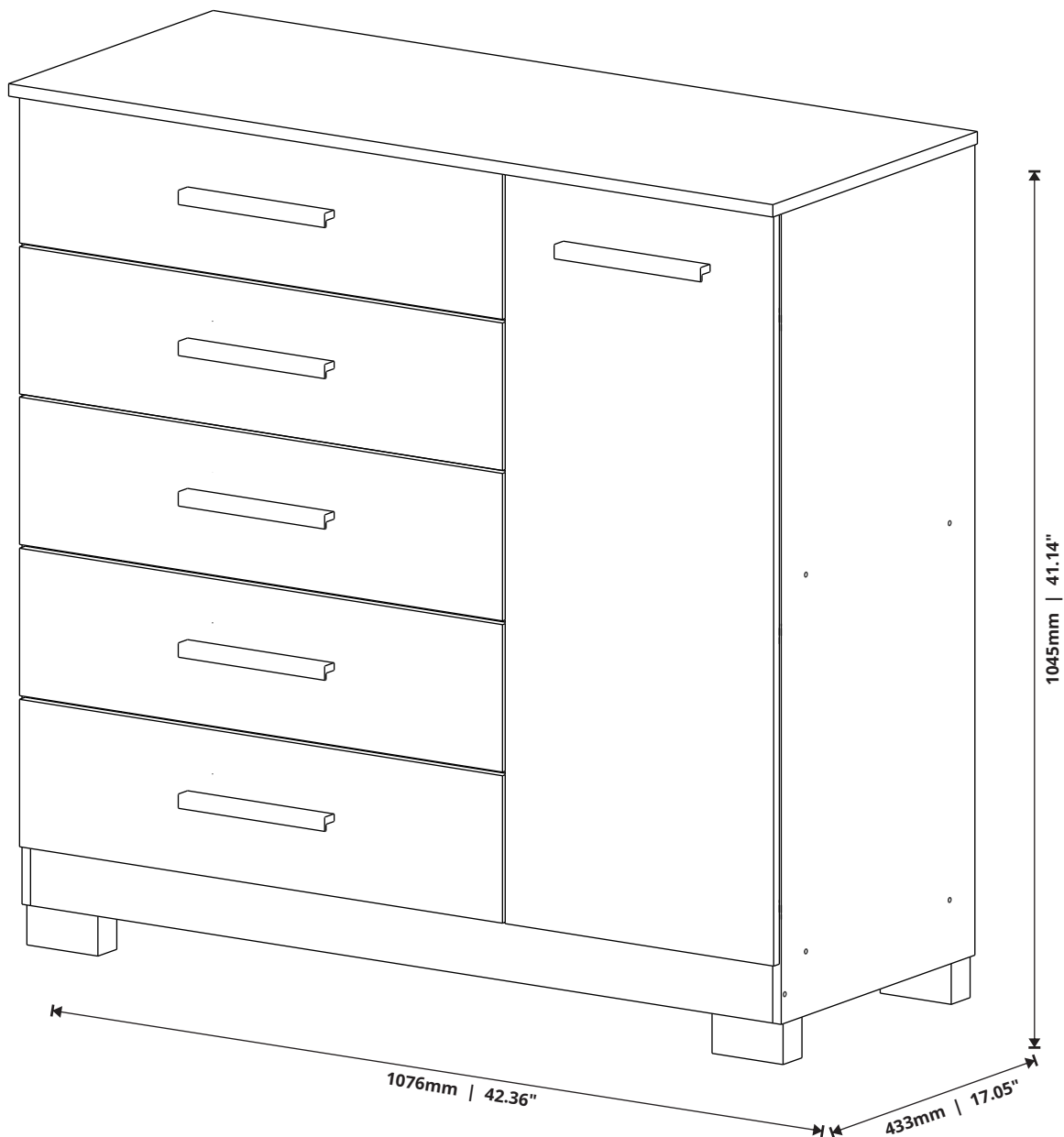

VITAMOV











COMODA ROMA ROMA CHEST COMODA ROMA

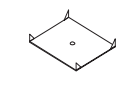
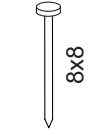
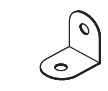
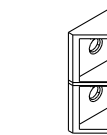
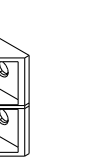
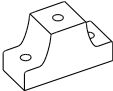
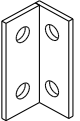

Rua Augusto Zanforlim, 1-25 - Distrito Industrial
CEP: 15520-000, Valentim Gentil/SP - Cx. Postal 18
Fone: (17) 3485-1336
vitamov@vitamov.com.br

ACESSÓRIOS

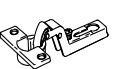
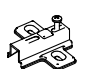
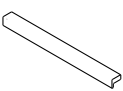
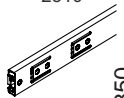
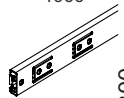
ACCESSORIES - ACCESORIOS

| | | | | | | | | | | | |
|--|---|---|---|---|---|--|---|---|---|---|---|
|  |  |  |  |  |  |  |  |  |  |  |  |
| PARAFUSO SCREW TORNILLO | PARAFUSO SCREW TORNILLO | PARAFUSO SCREW TORNILLO | PARAFUSO SCREW TORNILLO | PARAFUSO SCREW TORNILLO | PARAFUSO SCREW TORNILLO | CAVILHA DOWEL TARUGO | GARRAP/FUNDO BACK JOIN GARRA DE FUNDO | PREGO NAIL CLAVO | CANTONEIRA ANGLE BRAC. ESC. DE ANG. | CANTONEIRA PLAST. PLAST. ANGLE BRAC. ESC. DE ANG. | FECHADURA LOCK CERRADURA |
| A | B | C | D | E | F | G | H | I | J | K | L |
| 31x | 12x | 04x | 40x | 62x | 96x | 57x | 08x | 25x | 11x | 12x | 04x |
|  |  |  |  |  |  |  |  |  |  | | |
| DIST. CORREDIÇA SLIDER SPACER ESP. CORREDERA | CANTON. 4 FURUS 4 HOLES ANG. BRAC. ESC. DE ANG. | TAPAFURO CAP TAPA | DOBRADIÇA HINGE BISAGRA | CALÇO HINGE BASE BASE BISAGRA | PUXADOR HANDLE MANIJA | COR. TElesc. TElesc. SLIDER COR. TElesc. | COR. TElesc. TElesc. SLIDER COR. TElesc. | PÉS LEGS PIES | PERFIL H H PROFILE PERFIL H | | |
| M | N | O | P | Q | R | S | T | U | V | | |
| 02x | 04x | 06x | 03x | 03x | 06x | 05x | 01x | 04x | 01x | | |
| | | | | | | COD. ASSIST. 4829 | COD. ASSIST. 2510 | COD. ASSIST. 1966 | COD. ASSIST. 5156 | | |

CAPACIDADE DE CARGA

LOAD CAPACITY - CAPACIDAD DE CARGA

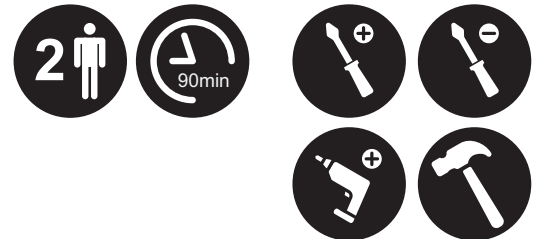
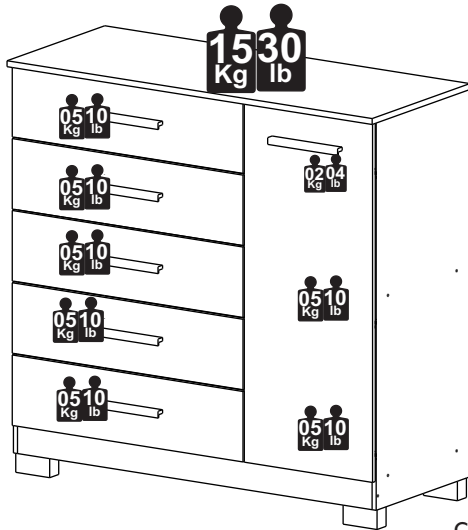

AS FERRAMENTAS NECESSÁRIAS PARA A MONTAGEM DO PRODUTO NÃO SÃO FORNECIDAS PELA EMPRESA.
THE TOOLS NEEDED FOR THE PRODUCT ASSEMBLY ARE NOT PROVIDED BY THE COMPANY.
LAS HERRAMIENTAS NECESARIAS PARA LA EL MONTAJE DEL PRODUCTO NO SON PROPORCIONADO POR LA EMPRESA.

A CAPACIDADE DE CARGA INDICADA É DISTRIBUÍDA NAS ÁREAS DEMONSTRADAS.

THE INDICATED LOAD CAPACITY IS DISTRIBUTED IN THE SHOWN AREAS.
LA CAPACIDAD DE CARGA INDICADA ES DISTRIBUIDA EN ZONAS DEMONSTRADAS.

CERTIFICADO DE GARANTIA

CERTIFICATE OF WARRANTY - CERTIFICADO DE GARANTÍA

DISPOSIÇÕES

O projeto, instalação e a montagem na residência do consumidor não é responsabilidade da Vitamov. A montagem deve seguir corretamente as instruções que se encontram dentro da embalagem de cada módulo.

A Vitamov se reserva o direito de efetuar modificações de caráter técnico em seus produtos, sem aviso prévio.

EXCLUSÃO DA GARANTIA

O presente termo exclui de sua garantia:

- danos causados em consequência de acidentes, mau uso, manuseio ou deslocamento incorreto dos produtos;
- danos causados por montagem inadequada;
- danos em decorrência de agentes externos (inundações, incêndio, etc);
- defeitos oriundos de umidade excessiva

A fixação dos armários de forma segura e garantida depende da qualidade da parede na qual os mesmos serão instalados.

A Vitamov não se responsabiliza por danos causados por instalações dos armários em paredes inadequadas.

PROVISIONS

The design, installation and assembly in the consumer's home is not the responsibility of Vitamov. Assembly must correctly follow the instructions given found inside the packaging of each module. Vitamov reserves the right to make technical changes to its products without prior notice.

EXCLUSION OF WARRANTY

This term excludes from its warranty:

- damage caused as a result of accidents, misuse, incorrect handling or displacement of the products;
- damage caused by improper assembly;
- damage resulting from external agents (floods, fire, etc.);
- defects from excessive humidity. Fixing the cabinets safely and securely depends on the quality of the wall on which they will be installed. Vitamov is not responsible for damage caused by installing cabinets on inadequate walls.

PROVISIONES

El diseño, instalación y montaje en el domicilio del consumidor no es responsabilidad de Vitamov. El montaje debe seguir correctamente las instrucciones dadas que se encuentra dentro del embalaje de cada módulo. Vitamov se reserva el derecho de realizar cambios técnicos en sus productos sin previo aviso.

EXCLUSIÓN DE GARANTÍA

Este certificado excluye de su garantía:

- daños causados como consecuencia de accidentes, mal uso, manejo incorrecto o desplazamiento de los productos;
- daños causados por un montaje inadecuado;
- daños resultantes de agentes externos (inundaciones, incendios, etc.);
- defectos por exceso de humedad. La fijación de los gabinetes de manera segura y segura depende de la calidad de la pared en la que se instalarán.

Vitamov no es responsable de daños causados por instalar gabinetes en paredes inadecuadas.

PEÇAS

PIECES - PIEZAS

| Nº PÇ | PORTUGUÊS | ENGLISH | ESPAÑOL | Medidas/Measures/ Medidas | Qtde. | Cod. Assist. |
|-------|---------------------------|---------------------------|------------------------------|---------------------------|-------|--------------|
| 1 | Tampo | Top | Tapa | 1076 x 433 x 15 | 1 | 5139 |
| 2 | Base | Base | Base | 381 x 410 x 15 | 1 | 5151 |
| 3 | Lateral Direita | Right Side | Lado Derecho | 980 x 410 x 12 | 1 | 5149 |
| 4 | Lateral Esquerda | Left Side | Lado Izquierdo | 980 x 410 x 12 | 1 | 5150 |
| 5 | Divisória | Partition | Partición | 895 x 410 x 12 | 1 | 5154 |
| 6 | Prateleira | Shelf | Repisa | 385 x 367 x 12 | 1 | 5152 |
| 7 | Porta | Door | Puerta | 907 x 378 x 12 | 1 | 5153 |
| 8 | Frente de Gaveta Maior | Bigger Drawer Front | Frente de Cajón Grande | 680 x 176 x 12 | 5 | 5140 |
| 9 | Frente de Gaveta Menor | Smaller Drawer Front | Frente de Cajón Pequeño | 324 x 176 x 12 | 1 | 5141 |
| 10 | Contra Fundo Maior | Bigger Counter Bottom | Contra Fondo Grande | 642 x 120 x 12 | 5 | 5143 |
| 11 | Contra Fundo Menor | Smaller Counter Bottom | Contra Fondo Pequeño | 320 x 100 x 12 | 1 | 5146 |
| 12 | Lateral Esq. Gaveta Maior | Bigger Left Drawer Side | Lado Izquierdo Cajón Grande | 350 x 100 x 12 | 5 | 5146 |
| 13 | Lateral Dir. Gaveta Maior | Bigger Right Drawer Side | Lado Derecho Cajón Grande | 350 x 100 x 12 | 5 | 5146 |
| 14 | Lateral Esq. Gaveta Menor | Smaller Left Drawer Side | Lado Izquierdo Cajón Pequeño | 300 x 100 x 12 | 1 | 5147 |
| 15 | Lateral Dir. Gaveta Menor | Smaller Right Drawer Side | Lado Derecho Cajón Pequeño | 300 x 100 x 12 | 1 | 5147 |
| 16 | Trava da Gaveta | Drawer Frame | Moldura de Cajón | 350 x 50 x 12 | 5 | 5142 |
| 17 | Trava Reforço | Reinforcement Lock | Moldura de Refuerzo | 666 x 70 x 12 | 1 | 5144 |
| 18 | Rodapé Frontal | Front Baseboard | Zócalo Frontal | 1045 x 70 x 15 | 1 | 5145 |
| 19 | Rodapé Traseiro | Back Baseboard | Zócalo Trasero | 1045 x 70 x 15 | 1 | 5145 |
| 20 | Fundo 1 | Back Panel 1 | Fondo 1 | 550 x 382 x 03 | 1 | 5157 |
| 21 | Fundo 2 | Back Panel 2 | Fondo 2 | 933 x 339 x 03 | 2 | 5217 |
| 22 | Fundo 3 | Back Panel 3 | Fondo 3 | 382 x 372 x 03 | 1 | 5266 |
| 23 | Fundo Gaveta Maior | Bigger Drawer Back | Fondo Cajón Grande | 640 x 360 x 03 | 5 | 5158 |
| 24 | Fundo Gaveta Menor | Smaller Drawer Back | Fondo Cajón Pequeño | 318 x 316 x 03 | 1 | 5159 |

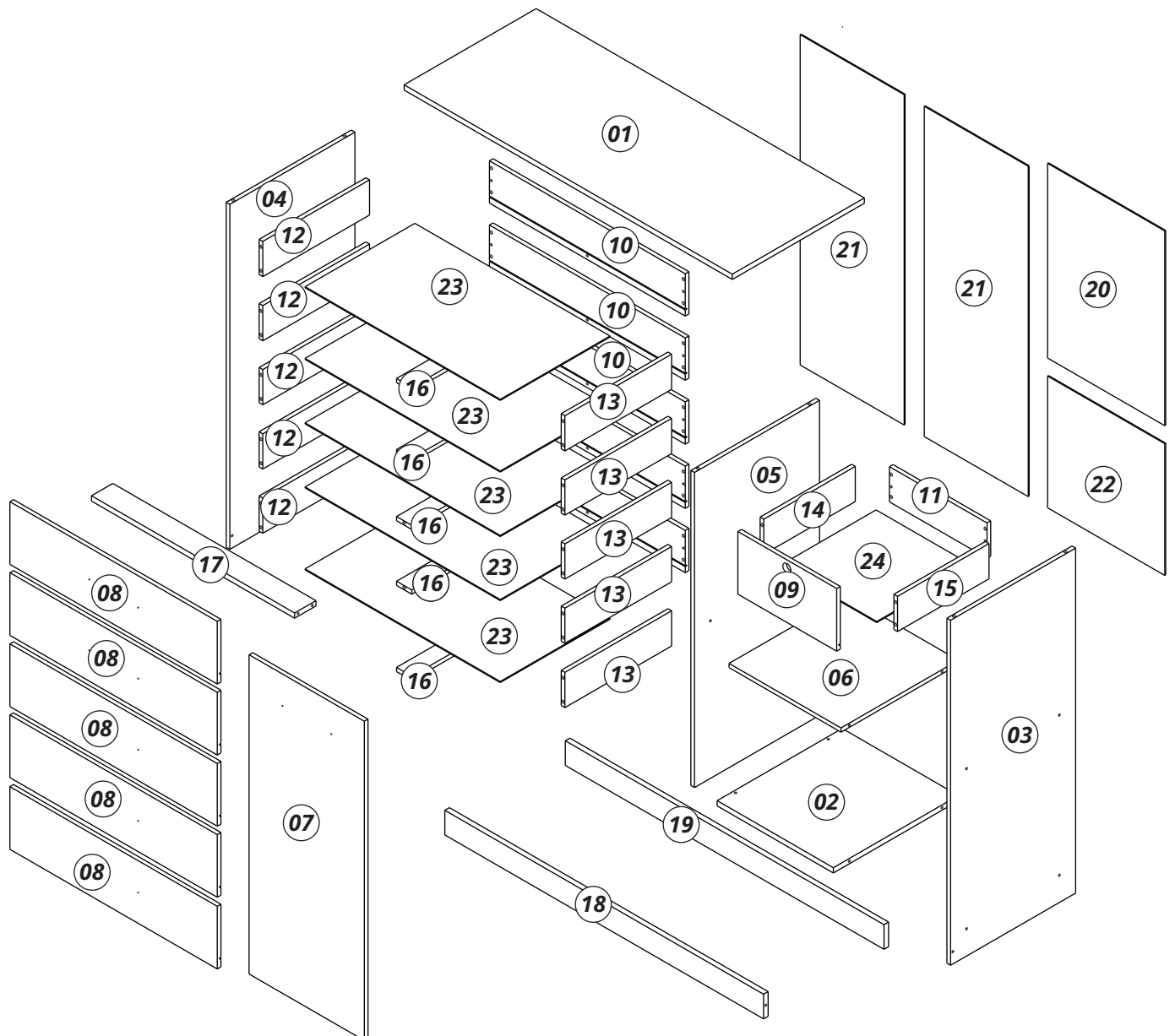

PRÉ-MONTAGEM

PRE ASSEMBLY - PRÉ-MONTAJE

IMPORTANT ATTENTION - IMPORTANTE
 A MONTAGEM DEVE SER REALIZADA POR UM PROFISSIONAL DE MONTAGEM.
 ASSEMBLY MUST BE CARRIED OUT BY AN ASSEMBLY PROFESSIONAL.
 EL MONTAJE DEBE SER HECHO POR UN MONTADOR DE MUEBLES.

1

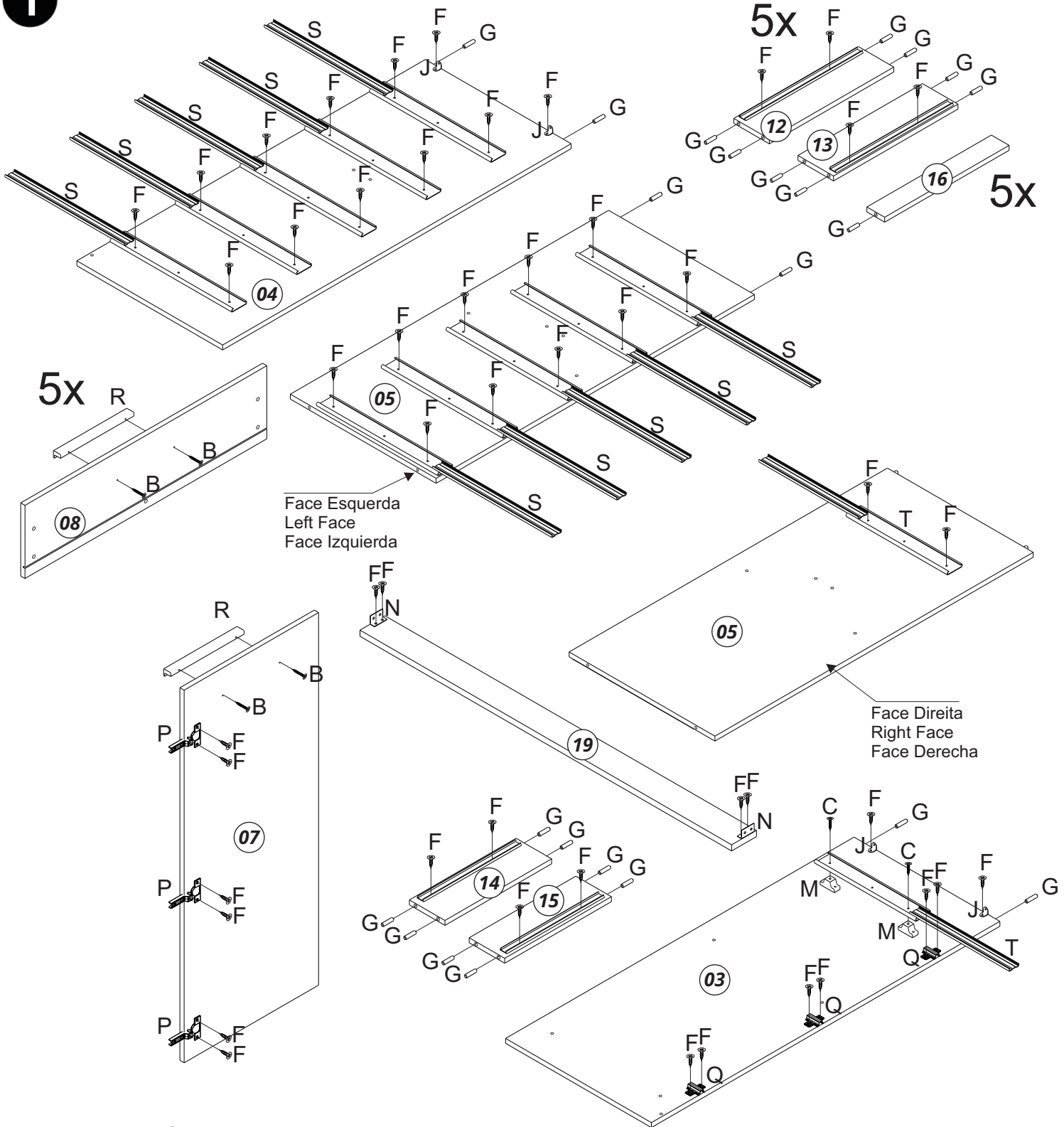

INSTRUÇÕES

INSTRUCTIONS - INSTRUCCIONES

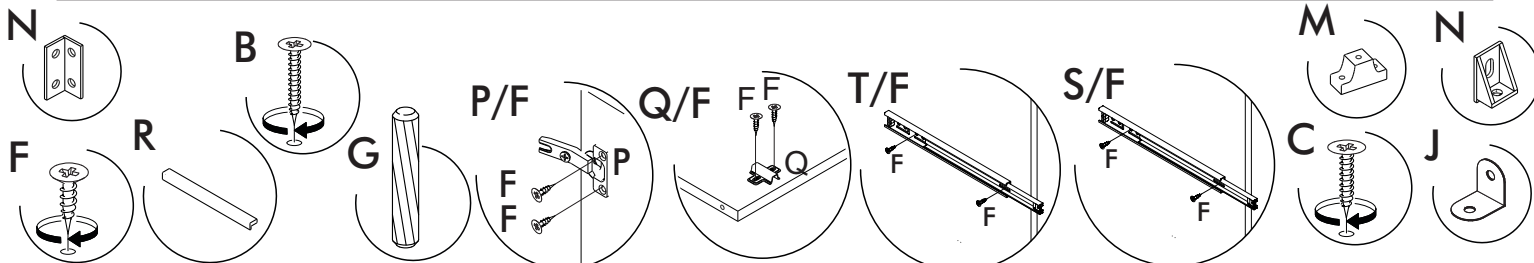

MONTAGEM

ASSEMBLY - MONTAJE

1

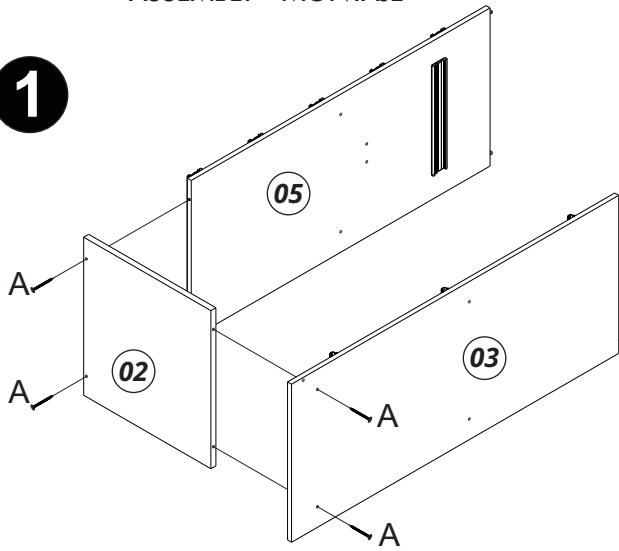

2

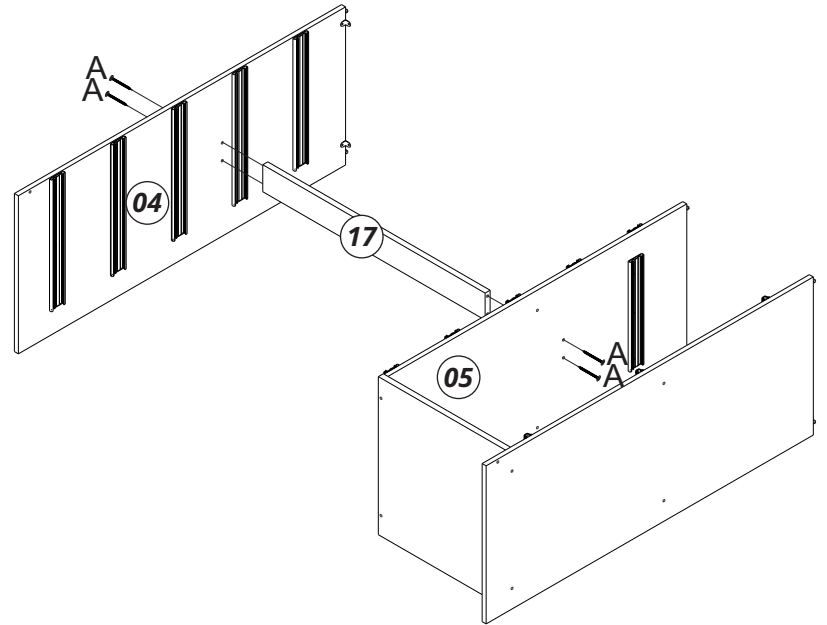

3

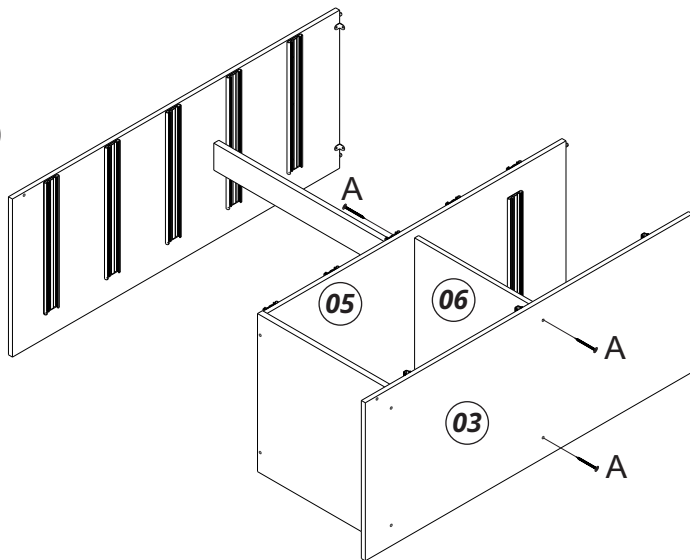

4

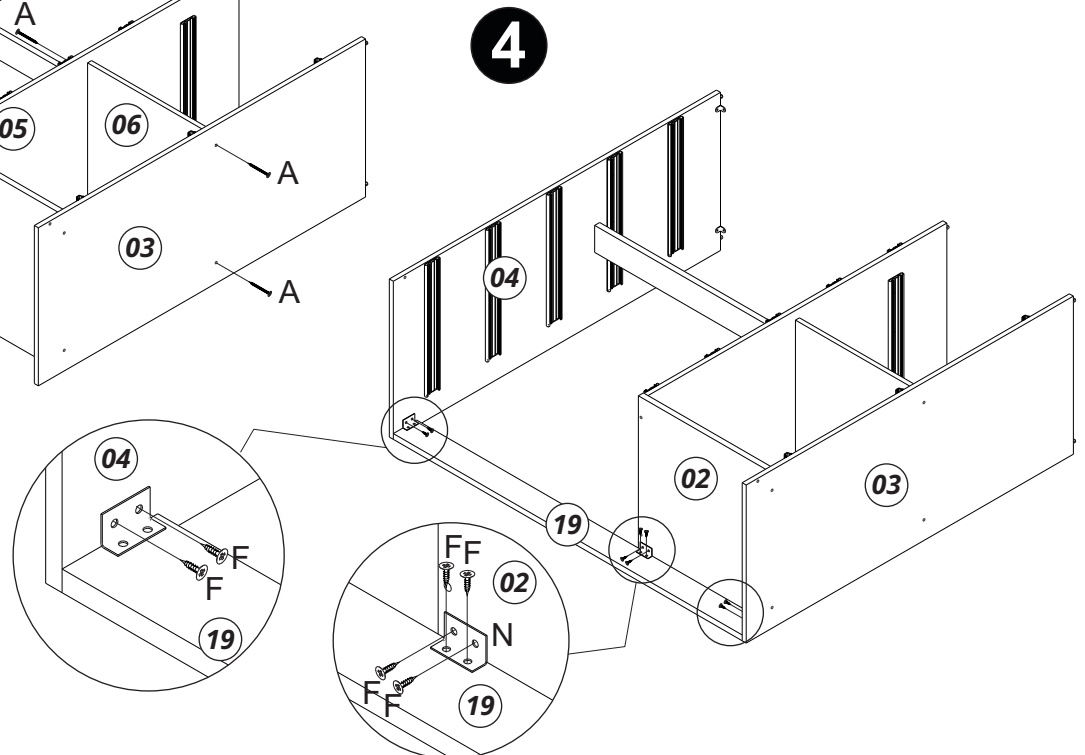

INSTRUÇÕES

INSTRUCTIONS - INSTRUCCIONES

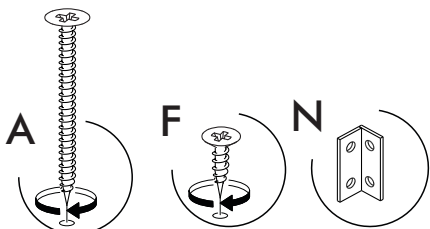

MONTAGEM

ASSEMBLY - MONTAJE

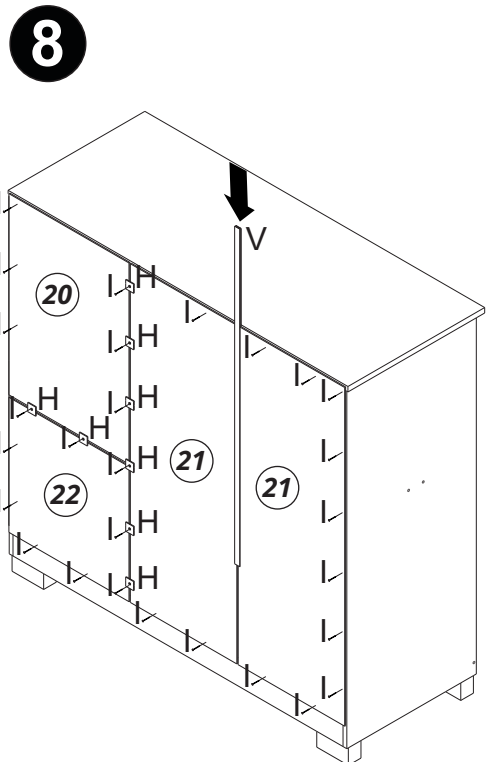
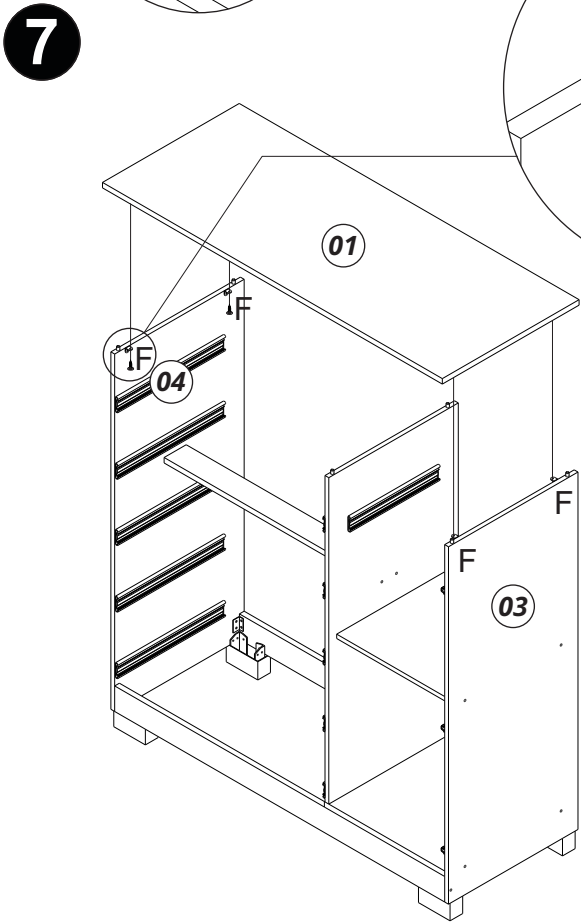
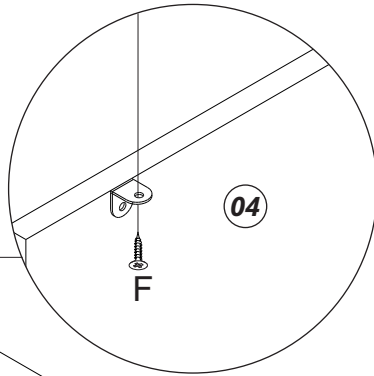
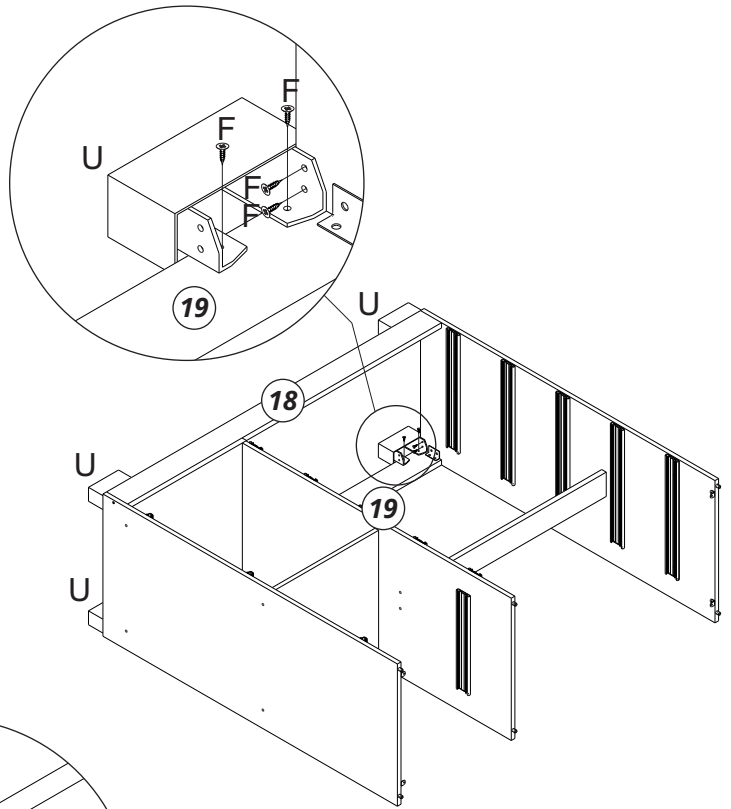
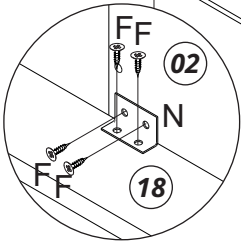
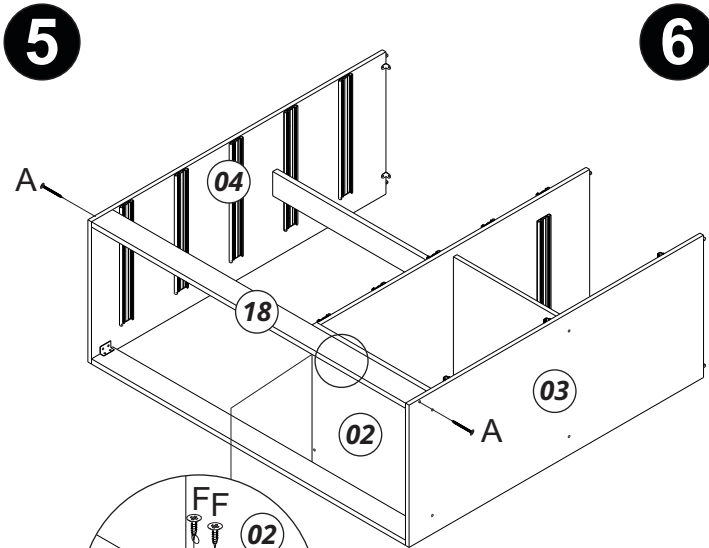

INSTRUÇÕES

INSTRUCTIONS - INSTRUCCIONES

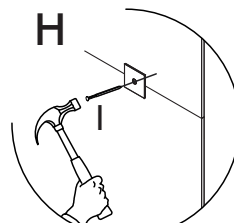
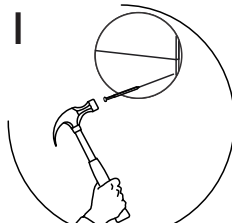
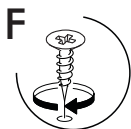
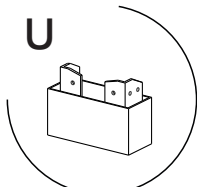
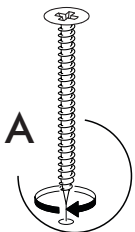

MONTAGEM

ASSEMBLY - MONTAJE

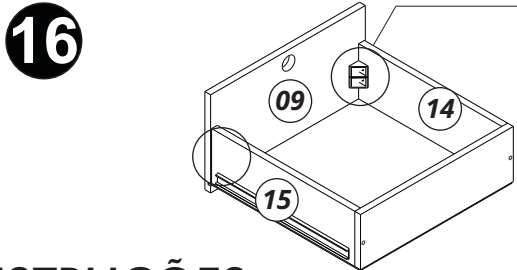
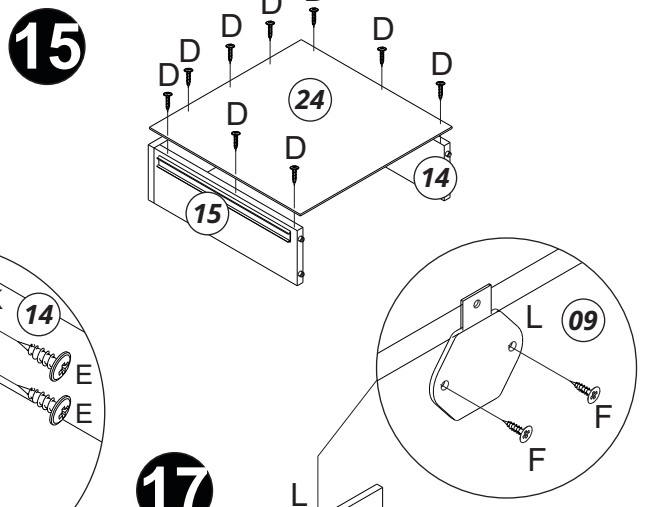
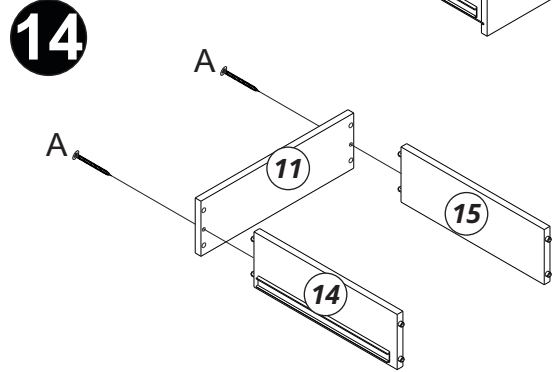
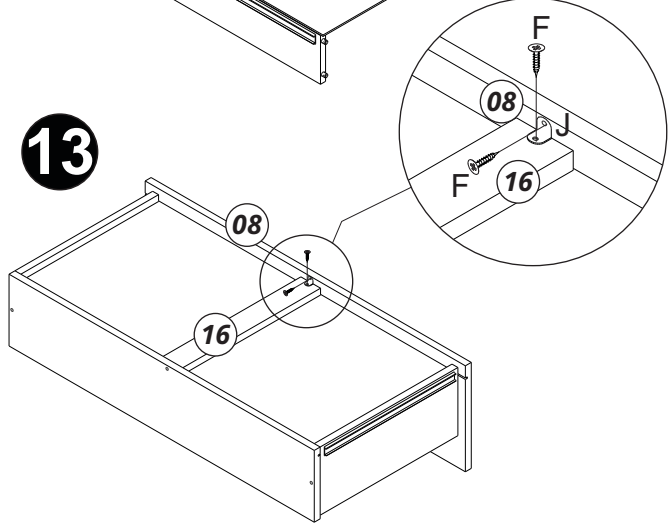
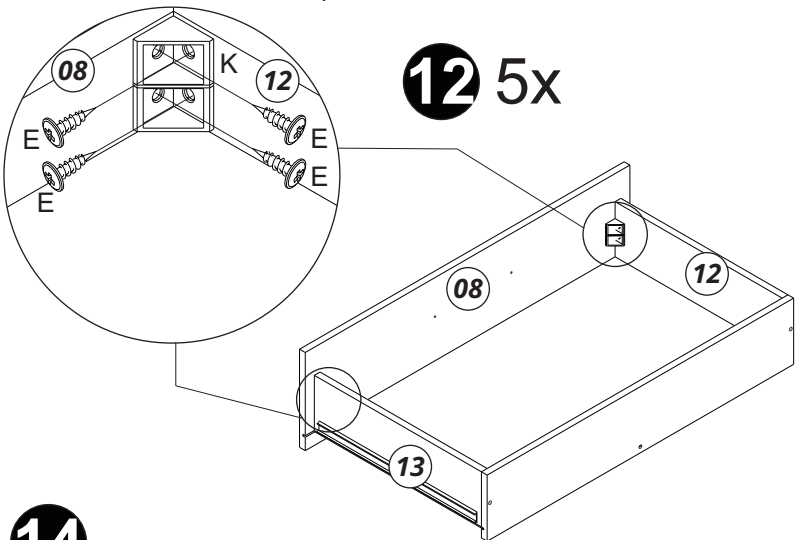
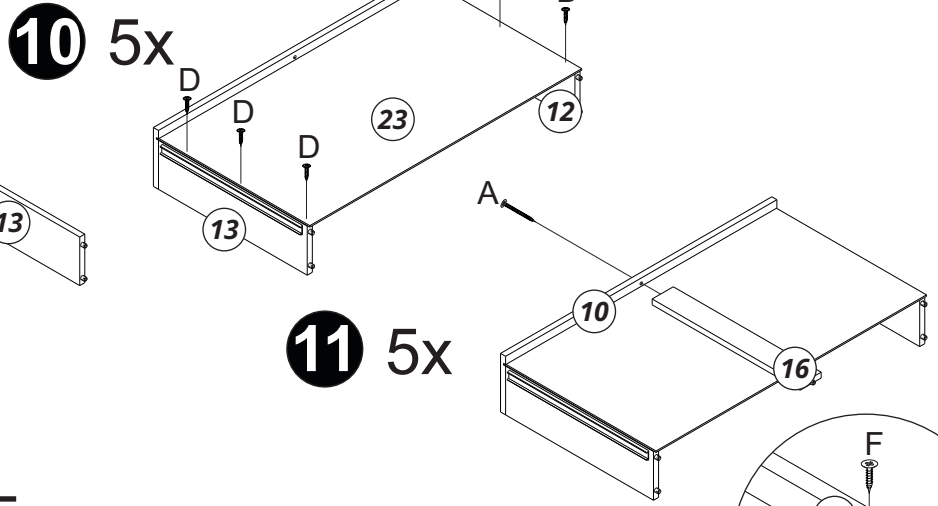
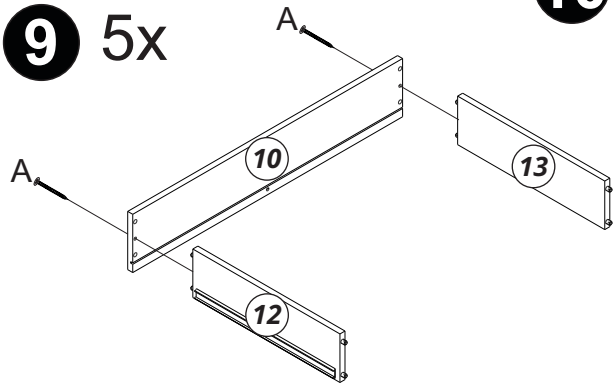

INSTRUÇÕES

INSTRUCTIONS - INSTRUCCIONES

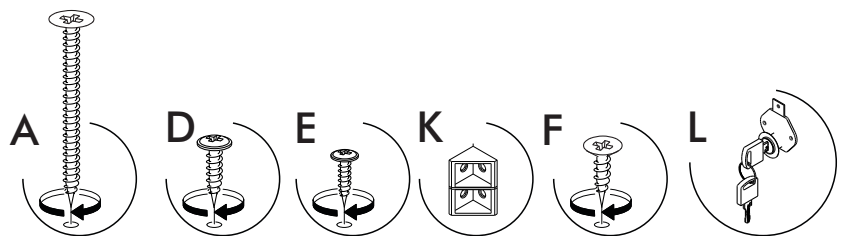

MONTAGEM

ASSEMBLY - MONTAJE

18

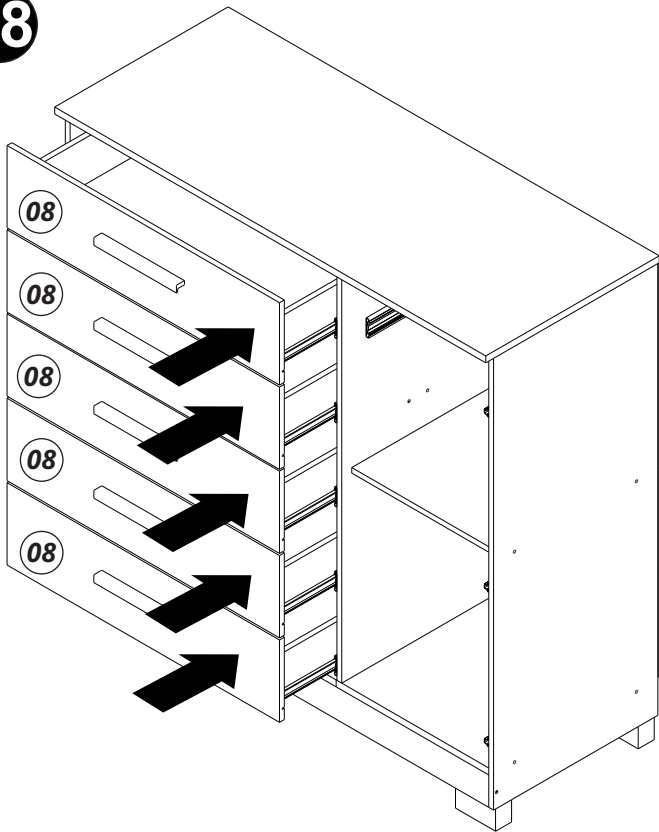

19

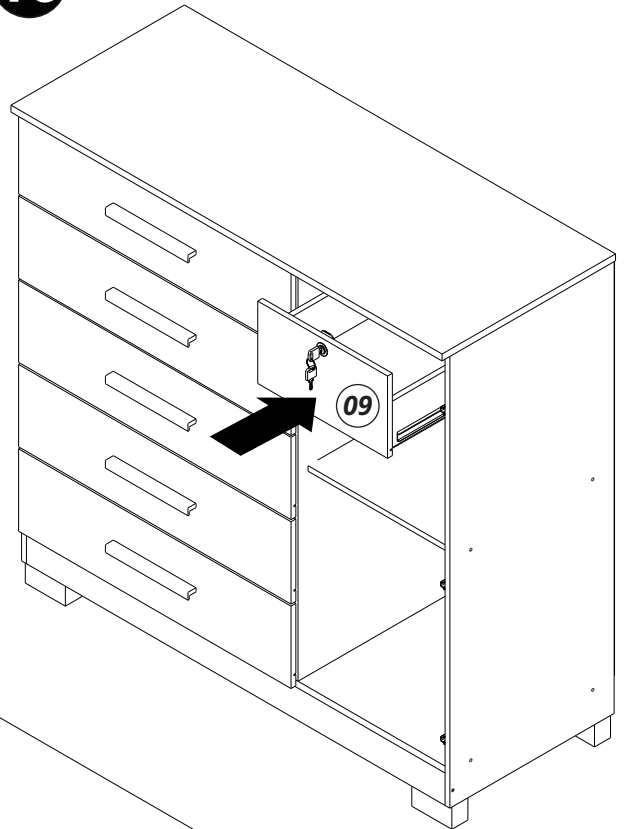

20

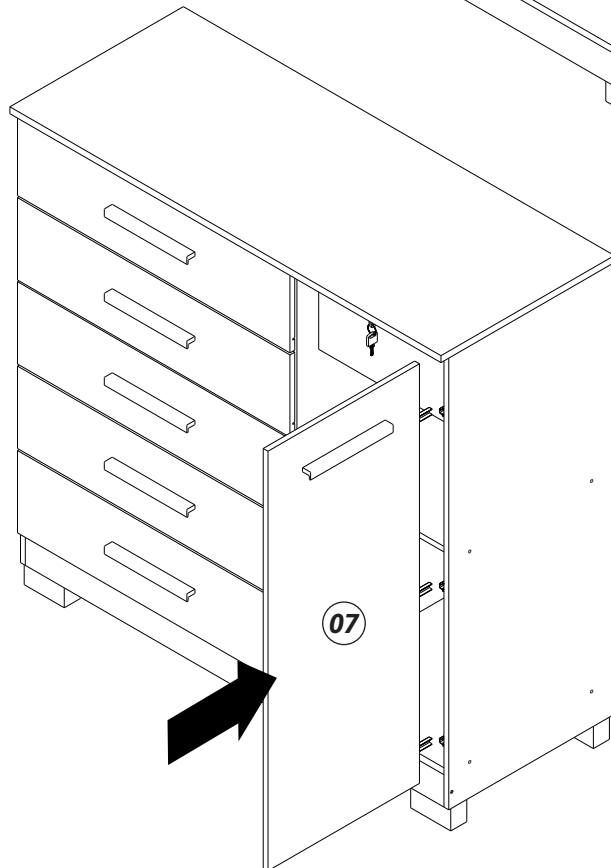

INSTRUÇÕES

INSTRUCTIONS - INSTRUCCIONES