

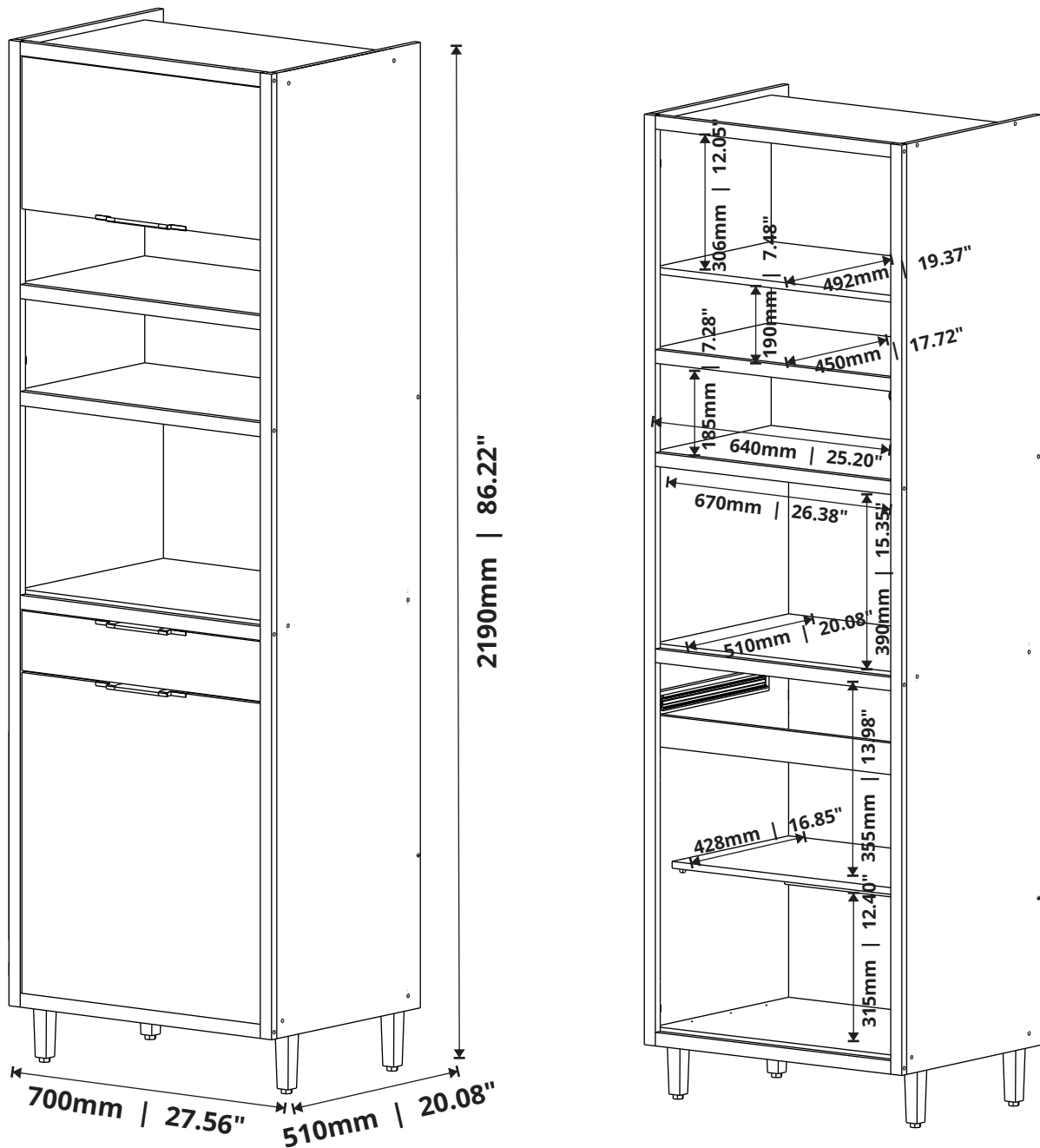

# VITAMOV

## TORRE BARONESA BARONESA TOWER TORRE BARONESA



Rua Augusto Zanforlim, 1-25 - Distrito Industrial  
CEP: 15520-000, Valentim Gentil/SP - Cx. Postal 18  
Fone: (17) 3485-1336  
vitamov@vitamov.com.br

# ACESSÓRIOS

ACCESSORIES - ACCESORIOS

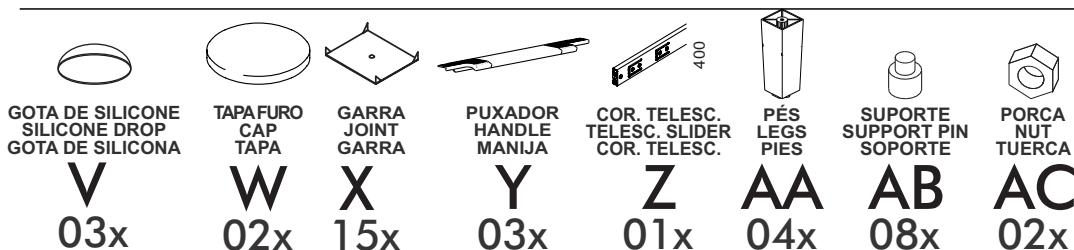
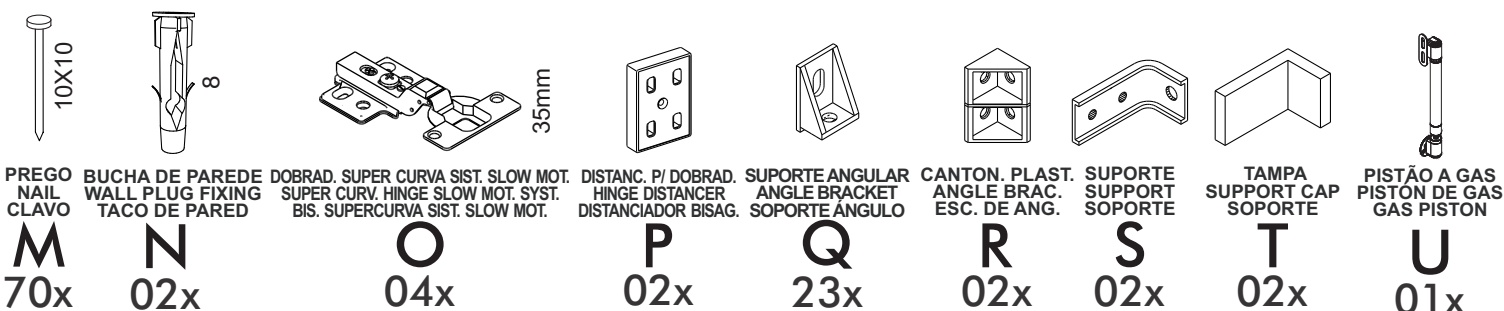
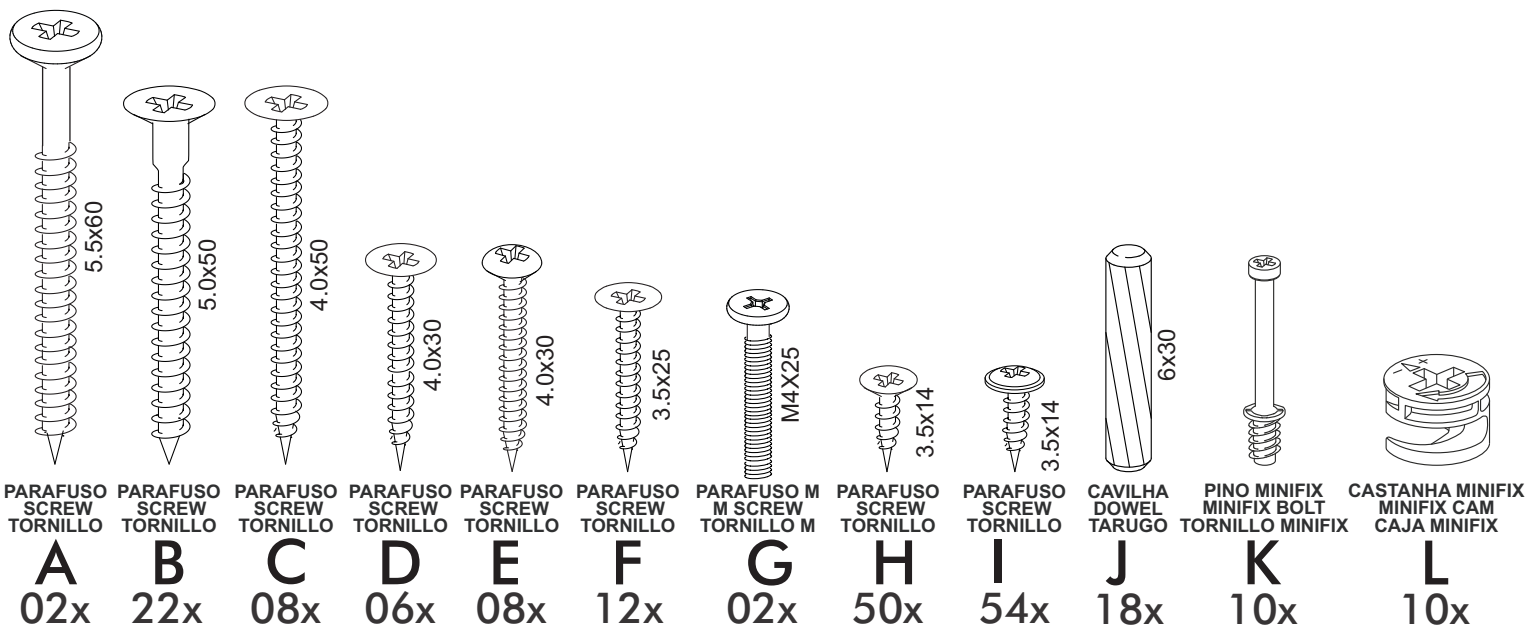

## CAPACIDADE DE CARGA

LOAD CAPACITY - CAPACIDAD DE CARGA

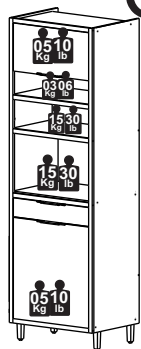

A CAPACIDADE DE CARGA INDICADA É DISTRIBUÍDA NAS ÁREAS DEMONSTRADAS.

THE INDICATED LOAD CAPACITY IS DISTRIBUTED IN THE SHOWN AREAS.

LA CAPACIDAD DE CARGA INDICADA ES DISTRIBUIDA EN ZONAS DEMONSTRADAS.

## CERTIFICADO DE GARANTIA

CERTIFICATE OF WARRANTY - CERTIFICADO DE GARANTÍA

### DISPOSIÇÕES

O projeto, instalação e a montagem na residência do consumidor não é responsabilidade da Vitamov. A montagem deve seguir corretamente as instruções que se encontram dentro da embalagem de cada módulo.

A Vitamov se reserva o direito de efetuar modificações de caráter técnico em seus produtos, sem aviso prévio.

### EXCLUSÃO DA GARANTIA

O presente termo exclui de sua garantia:

- danos causados em consequência de acidentes, mau uso, manuseio ou deslocamento incorreto dos produtos;
- danos causados por montagem inadequada;
- danos em decorrência de agentes externos (inundações, incêndio, etc);
- defeitos oriundos de umidade excessiva

A fixação dos armários de forma segura e garantida depende da qualidade da parede na qual os mesmos serão instalados.

A Vitamov não se responsabiliza por danos causados por instalações dos armários em paredes inadequadas.

### PROVISIONS

The design, installation and assembly in the consumer's home is not the responsibility of Vitamov. Assembly must correctly follow the instructions given found inside the packaging of each module. Vitamov reserves the right to make technical changes to its products without prior notice.

### EXCLUSION OF WARRANTY

This term excludes from its warranty:

- damage caused as a result of accidents, misuse, incorrect handling or displacement of the products;
- damage caused by improper assembly;
- damage resulting from external agents (floods, fire, etc.);
- defects from excessive humidity. Fixing the cabinets safely and securely depends on the quality of the wall on which they will be installed. Vitamov is not responsible for damage caused by installing cabinets on inadequate walls.

### PROVISIONES

El diseño, instalación y montaje en el domicilio del consumidor no es responsabilidad de Vitamov. El montaje debe seguir correctamente las instrucciones dadas que se encuentra dentro del embalaje de cada módulo. Vitamov se reserva el derecho de realizar cambios técnicos en sus productos sin previo aviso.

### EXCLUSIÓN DE GARANTÍA

Este certificado excluye de su garantía:

- daños causados como consecuencia de accidentes, mal uso, manejo incorrecto o desplazamiento de los productos;
- daños causados por un montaje inadecuado;
- daños resultantes de agentes externos (inundaciones, incendios, etc.);
- defectos por exceso de humedad.

La fijación de los gabinetes de manera segura y segura depende de la calidad de la pared en la que se instalarán.

Vitamov no es responsable de daños causados por instalar gabinetes en paredes inadecuadas.

# PEÇAS

PIECES - PIEZAS

Nº PÇ	PORTUGUÊS	ENGLISH	ESPAÑOL	Medidas/Measures/ Medidas	Qtde.	Cod. Assist.
1	Base	Base	Base	670 x 492 x 15	1	4689
2	Lateral Direita	Right Side	Lado Derecho	2060 x 492 x 15	1	4678
3	Lateral Esquerda	Left Side	Lado Izquierdo	2060 x 492 x 15	1	4679
4	Prateleira 1	Shelf 1	Repisa 1	670 x 428 x 15	1	4680
5	Prateleira 2	Shelf 2	Repisa 2	670 x 428 x 15	1	4681
6	Prateleira 3	Shelf 3	Repisa 3	670 x 428 x 15	1	4682
7	Prateleira 4 Inferior	Bottom Shelf 4	Repisa 4 Inferior	670 x 428 x 15	1	4699
8	Tampo Superior	Upper Top	Tapa Superior	670 x 428 x 15	1	4700
9	Batente de Porta	Door Flap	Solapa Puerta	670 x 70 x 15	1	4696
10	Trava Superior	Upper Frame	Moldura Superior	670 x 70 x 15	2	4692
11	Porta	Door	Puerta	684 x 636 x 15	1	4688
12	Porta Basculante	Swing Door	Puerta Abatible	636 x 325 x 15	1	4695
13	Frente de Gaveta	Drawer Front	Frente Del Cajón	636 x 128 x 15	1	4690
14	Lateral de Gaveta	Drawer Side	Lado Del Cajón	385 x 128 x 15	2	4697
15	Contra Fundo	Counter Bottom	Contra Fondo	615 x 80 x 15	1	4694
16	Suporte para Corrediça	Slider Support	Soporte Corredera	400 x 50 x 15	2	4698
17	Tampo	Top	Tapa	670 x 492 x 24	1	4691
18	Suporte Pé Lateral	Side Leg Support	Soporte Pié Lado	491 x 50 x 24	2	4693
19	Fundo de Gaveta	Drawer Back	Fondo Del Cajón	595 x 395 x 03	1	4685
20	Fundo 1	Back Panel 1	Fondo 1	694 x 296 x 03	1	4686
21	Fundo 2 c/ furo	Back Panel 2	Fondo 2	694 x 540 x 03	1	4702
22	Fundo 3 c/ Furo	Back Panel 3 w/ hole	Fondo 3 c/ Agujero	694 x 440 x 03	1	4703
23	Fundo 4	Back Panel 4	Fondo 4	670 x 433 x 03	1	4705
24	Fundo 5	Back Panel 5	Fondo 5	670 x 327 x 03	1	4687
25	Organizador de Talheres	Cutlery Organizer	Organizador de Cubiertos		1	4706
A16	Moldura Lateral Esquerda	Left Side Frame	Moldura Lado Izquierdo	2060 - Canal 21	1	4684
A17	Moldura Lateral Direita	Right Side Frame	Moldura Lado Derecho	2060 - Canal 21	1	4683
A7	Moldura Superior/Central	Center/Upper Frame	Moldura Superior/Central	642 - Canal 21	4	4512
A23	Moldura Inferior	Bottom Frame	Moldura Inferior	642 - Canal 16	1	4602

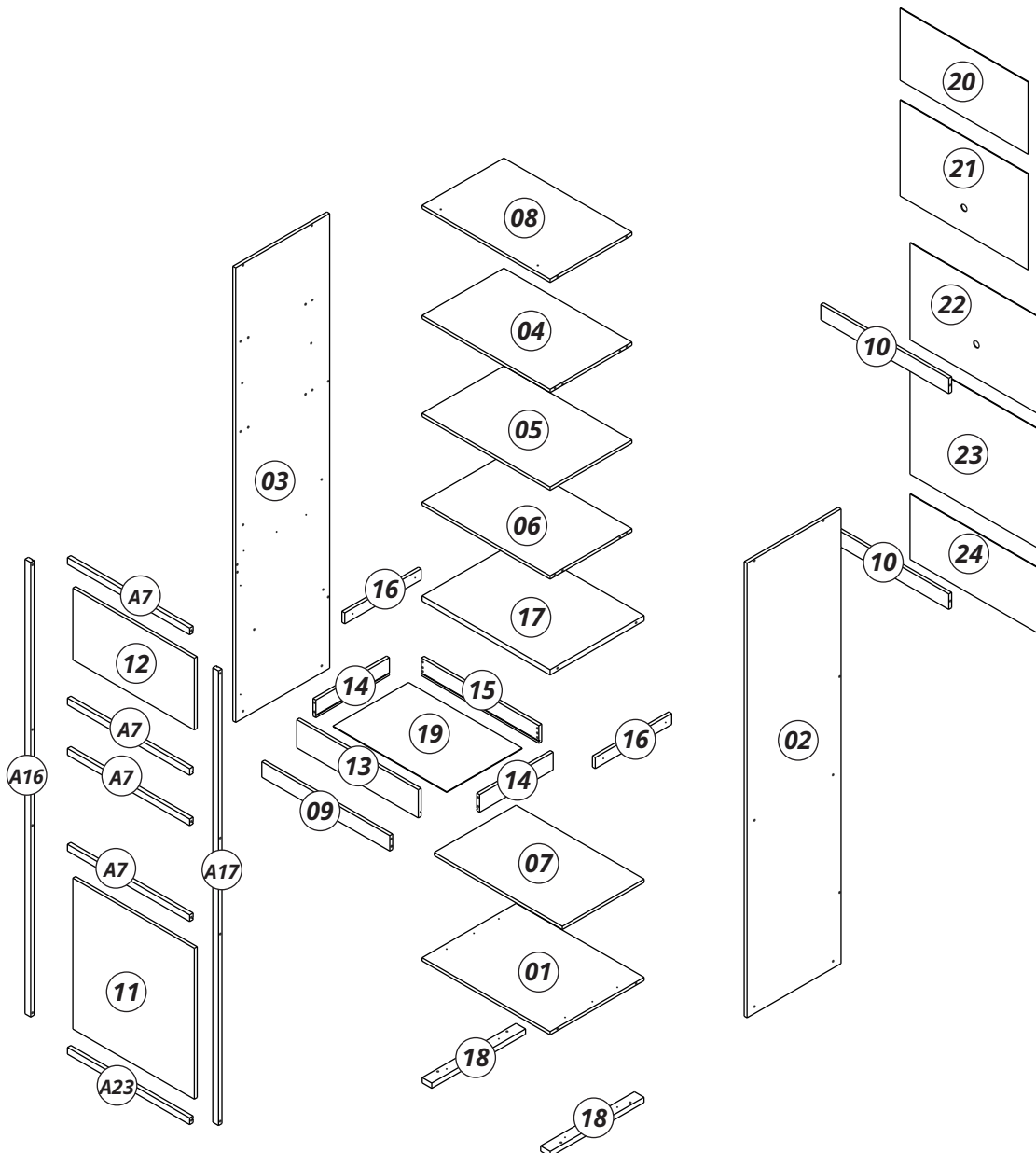

# PRÉ-MONTAGEM

PRE ASSEMBLY - PRÉ-MONTAJE

**IMPORTANT** ATTENTION - IMPORTANTE  
 A MONTAGEM DEVE SER REALIZADA POR UM PROFISSIONAL DE MONTAGEM.  
 ASSEMBLY MUST BE CARRIED OUT BY AN ASSEMBLY PROFESSIONAL.  
 EL MONTAJE DEBE SER HECHO POR UN MONTADOR DE MUEBLES.

1

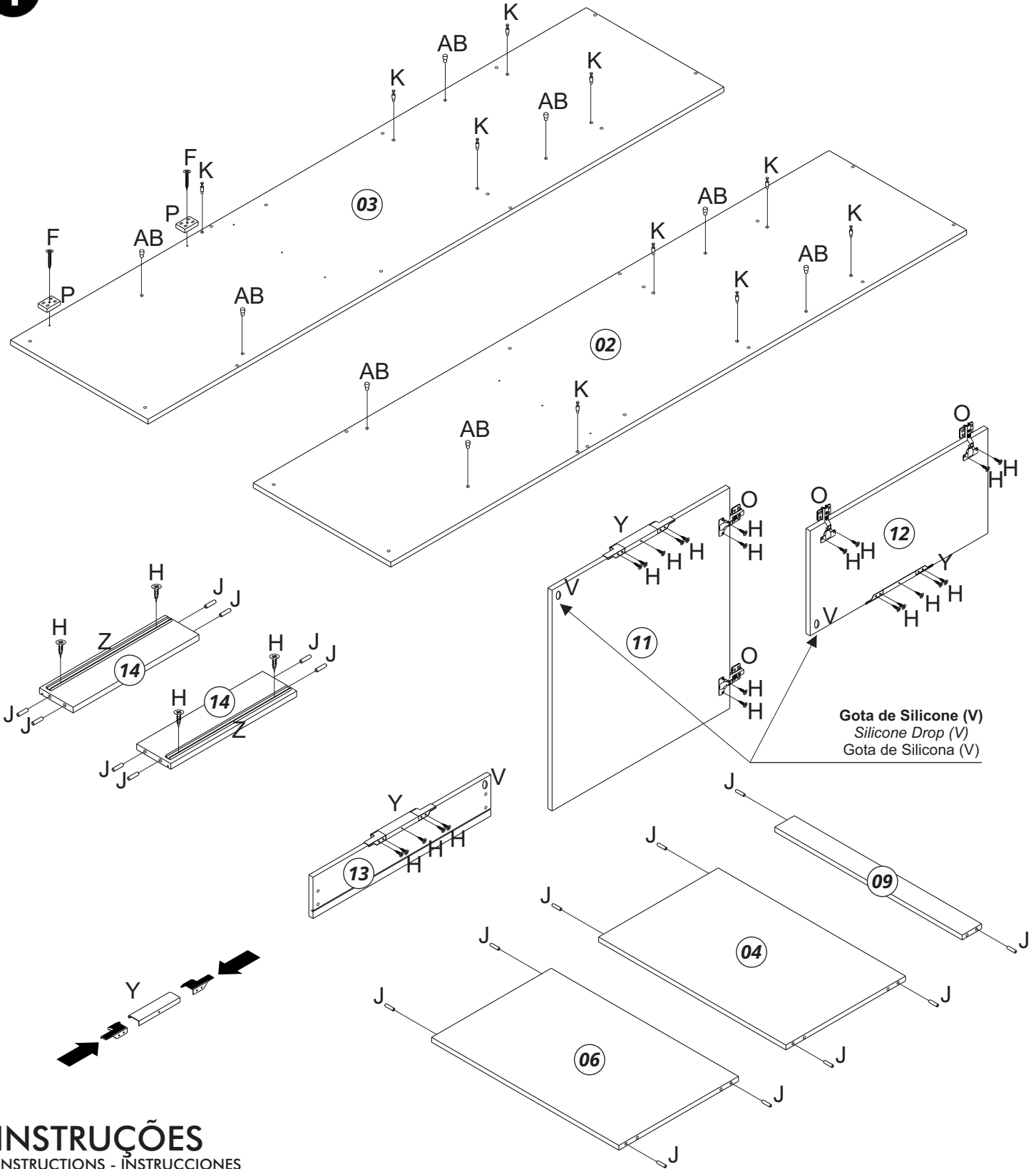

## INSTRUÇÕES

INSTRUCTIONS - INSTRUCCIONES

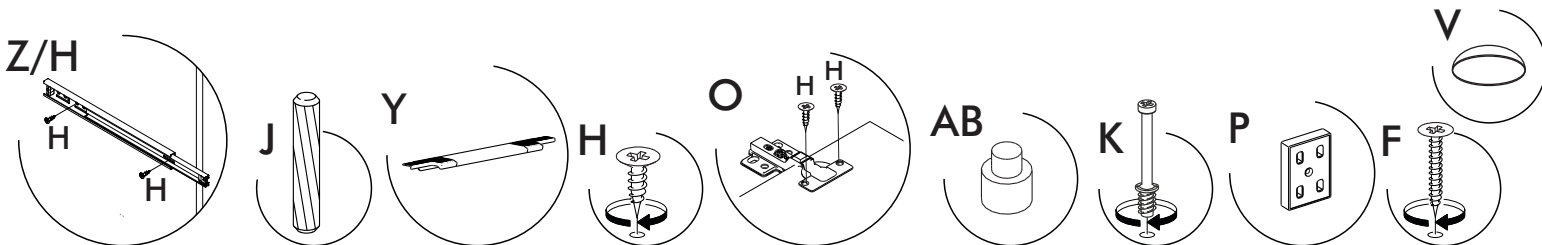

# MONTAGEM

ASSEMBLY - MONTAJE

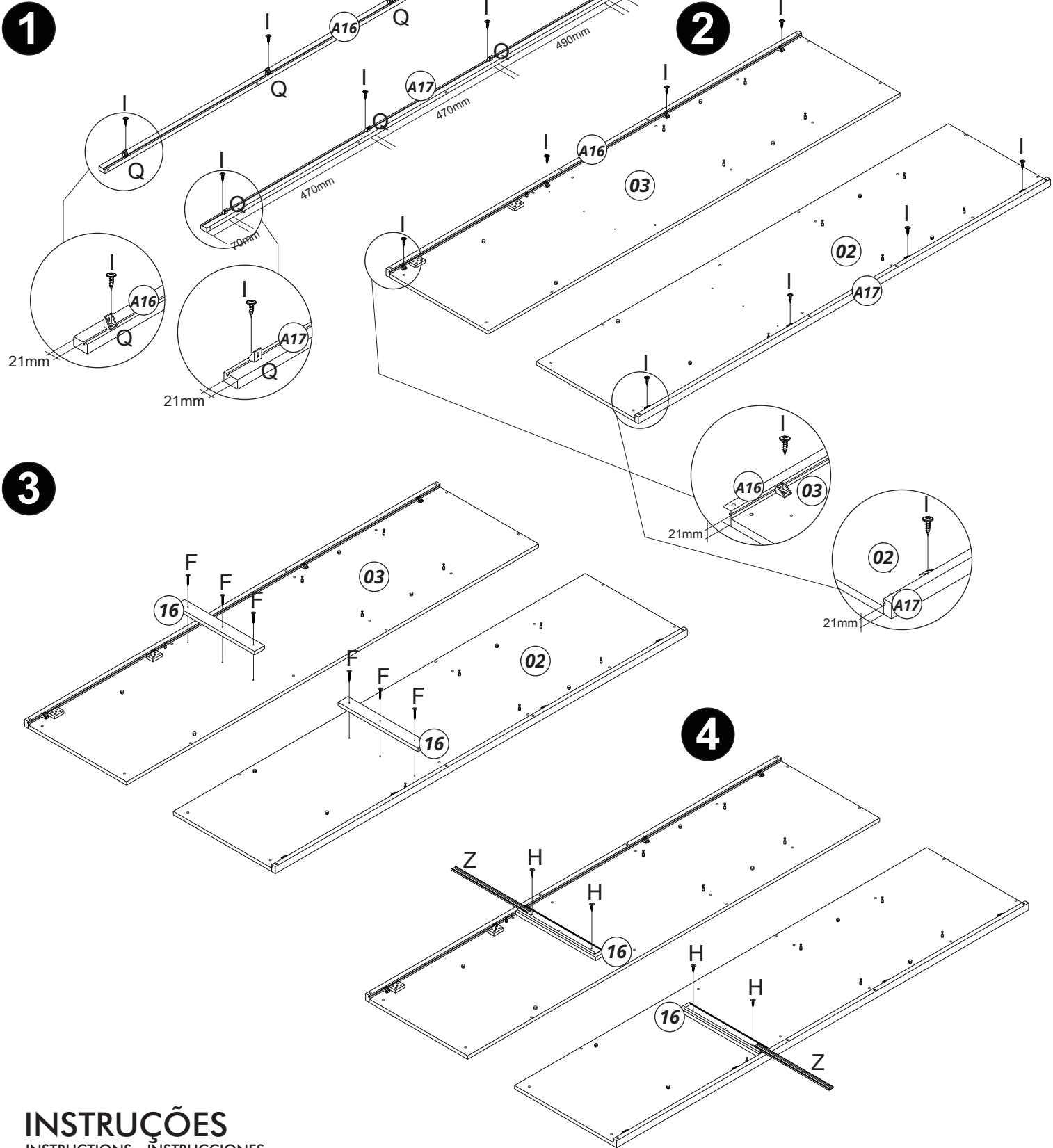

## INSTRUÇÕES

INSTRUCTIONS - INSTRUCCIONES

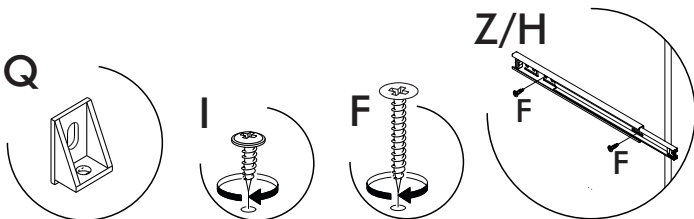

# MONTAGEM

ASSEMBLY - MONTAJE

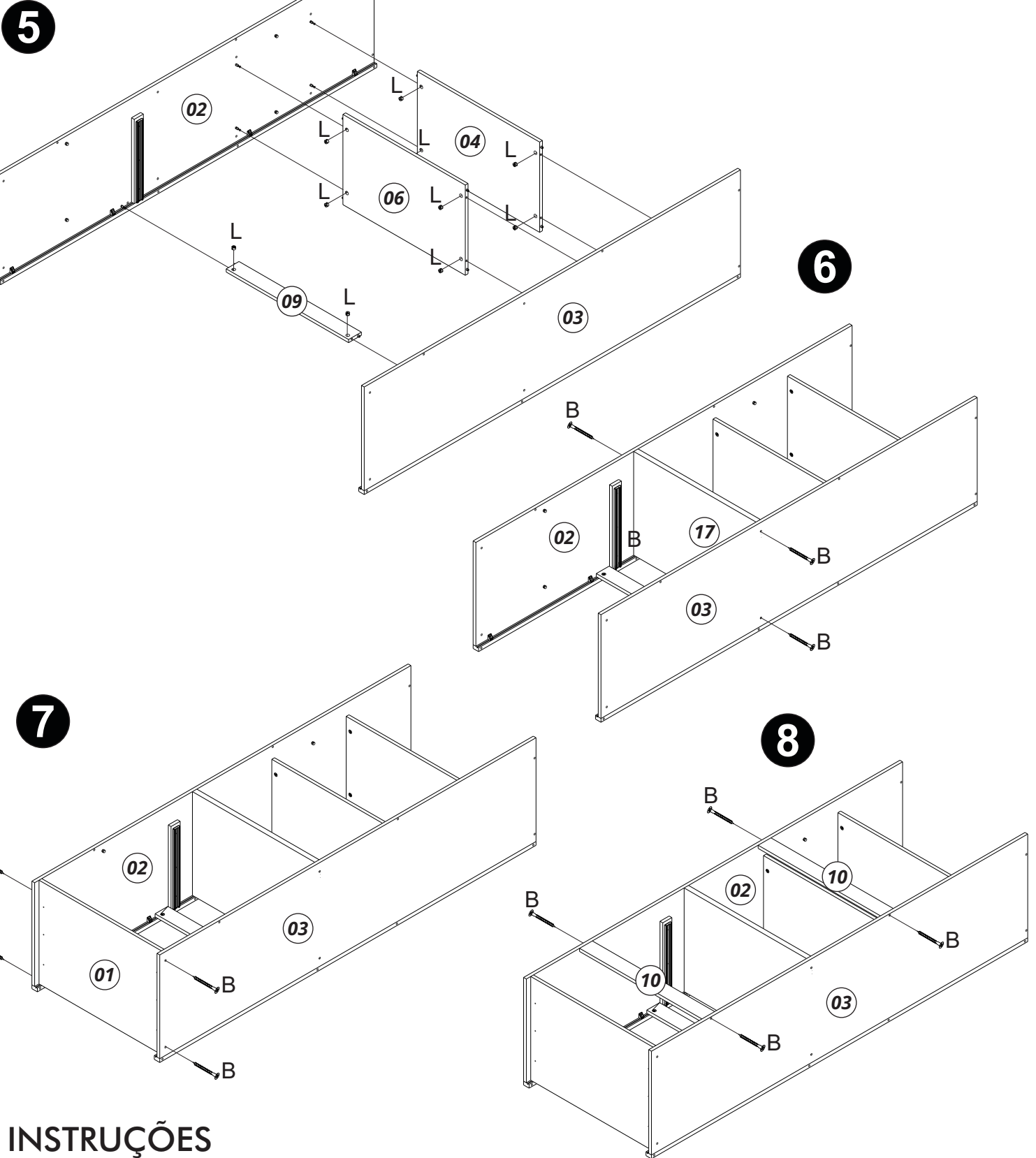

## INSTRUÇÕES

INSTRUCTIONS - INSTRUCCIONES

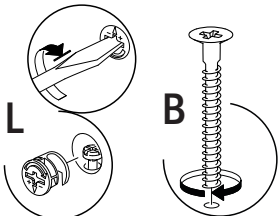

# MONTAGEM

ASSEMBLY - MONTAJE

9

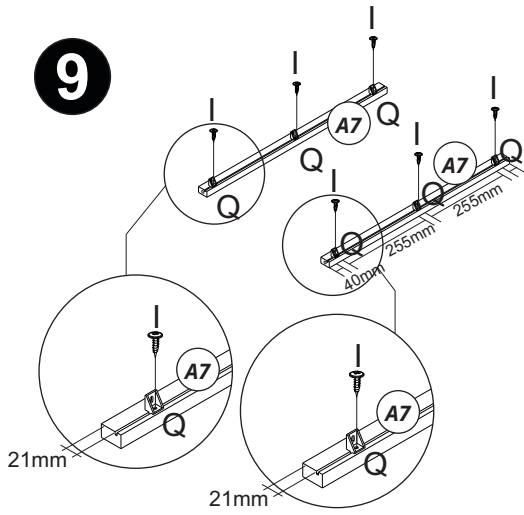

10

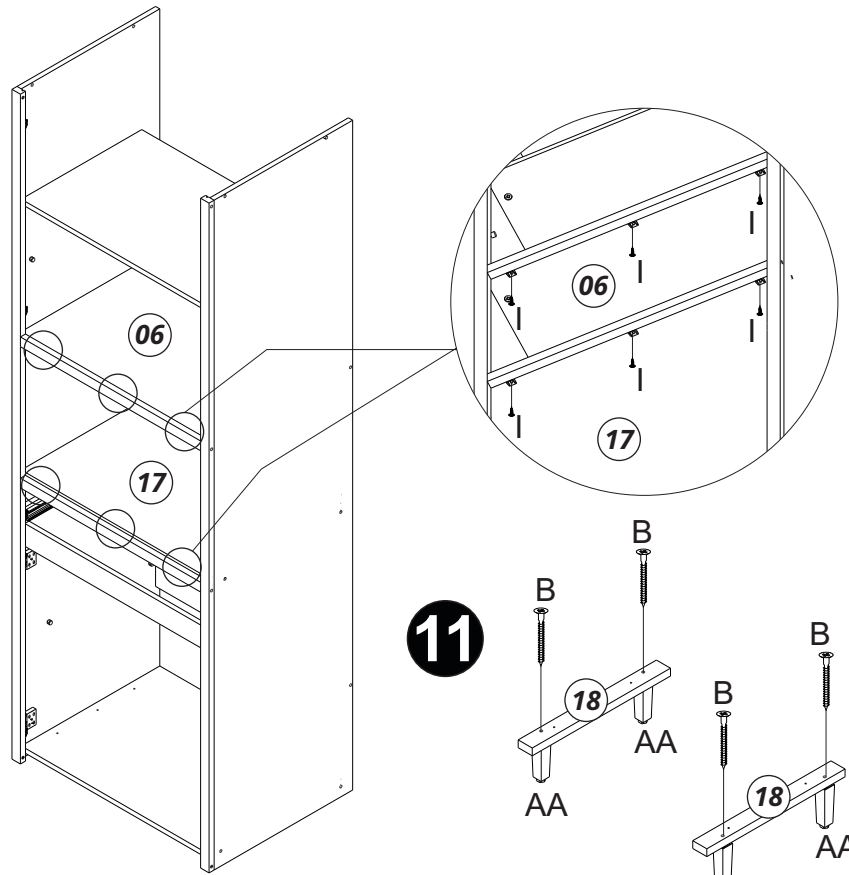

11

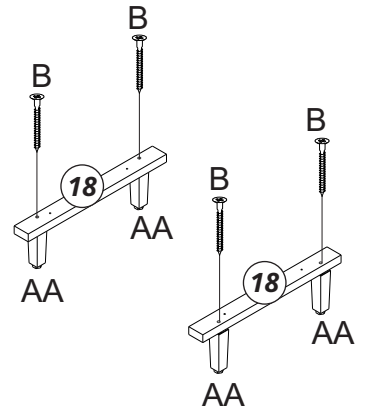

12

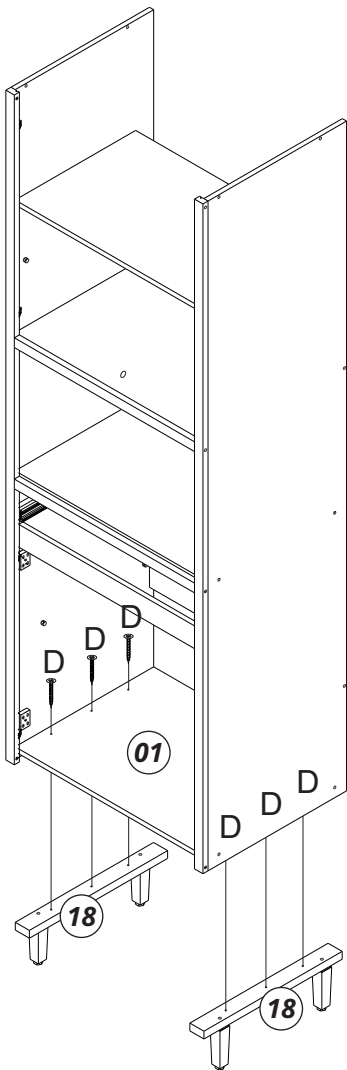

13

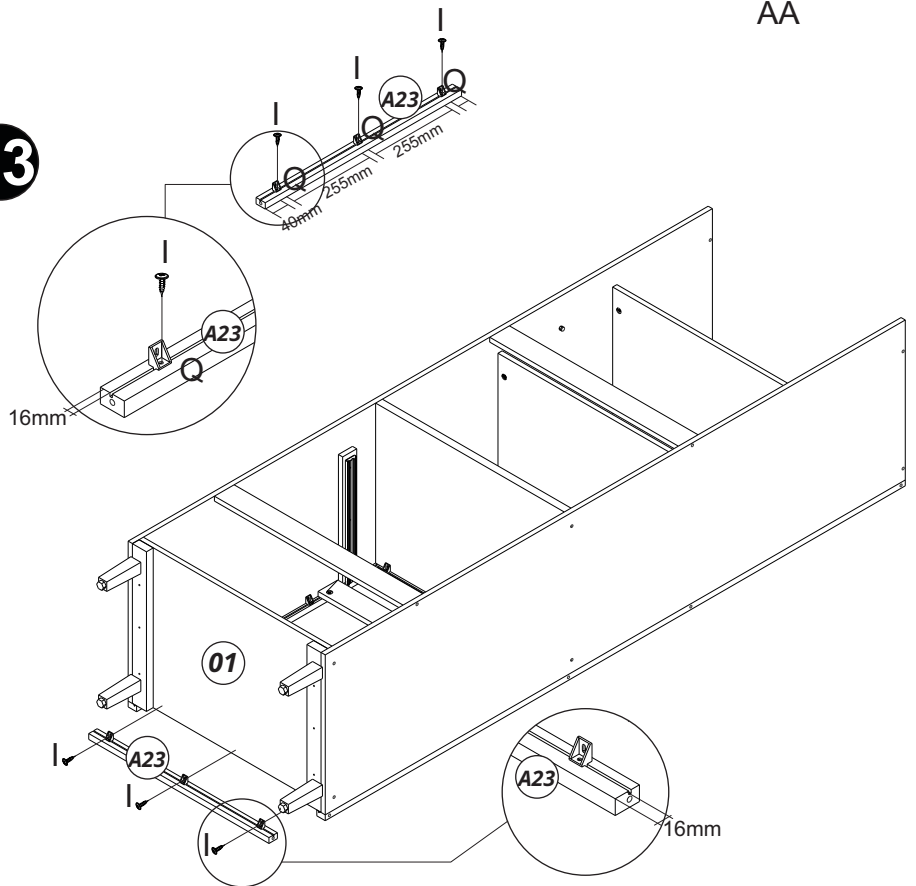

## INSTRUÇÕES

INSTRUCTIONS - INSTRUCCIONES

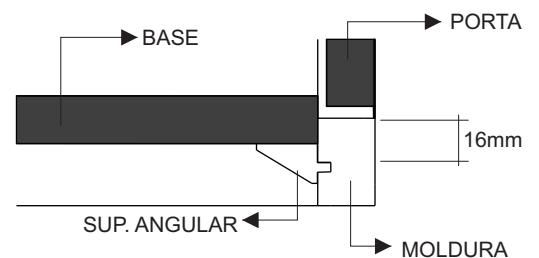
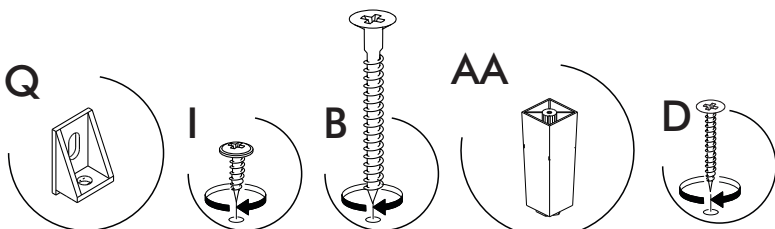

# MONTAGEM

ASSEMBLY - MONTAJE

14

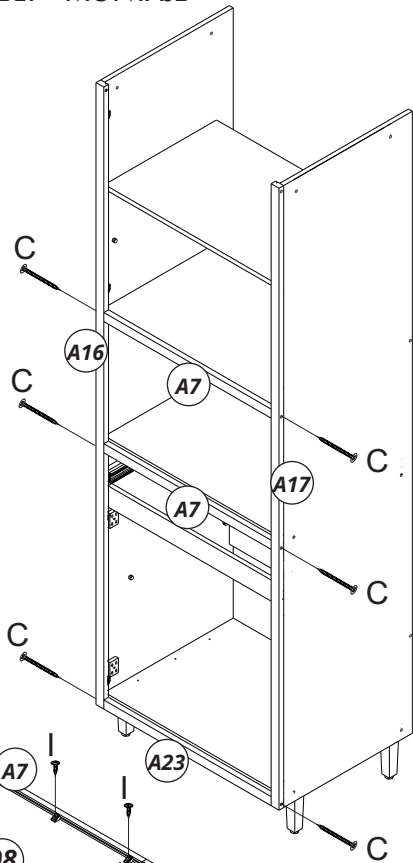

15

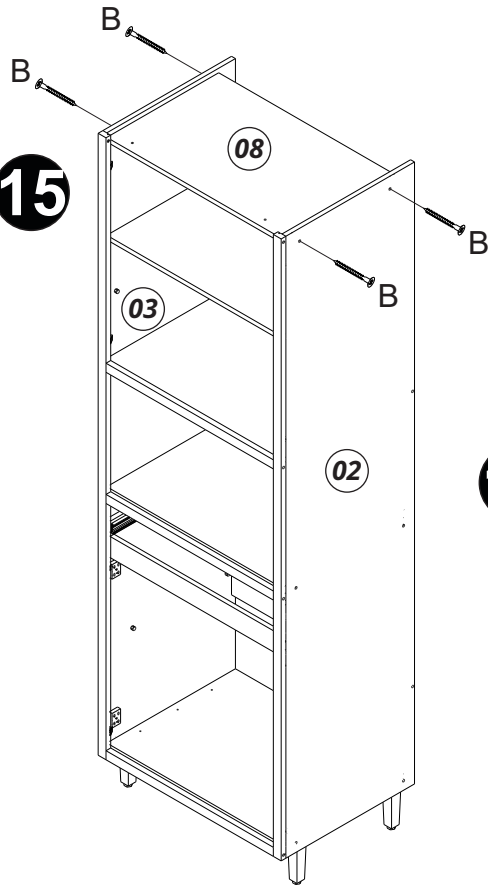

16

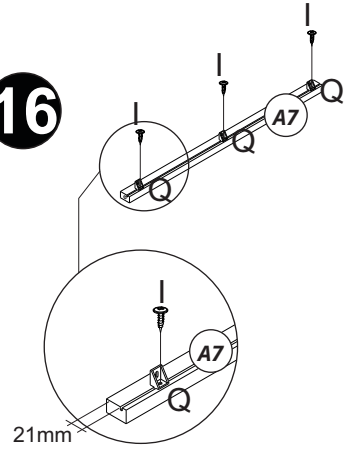

17

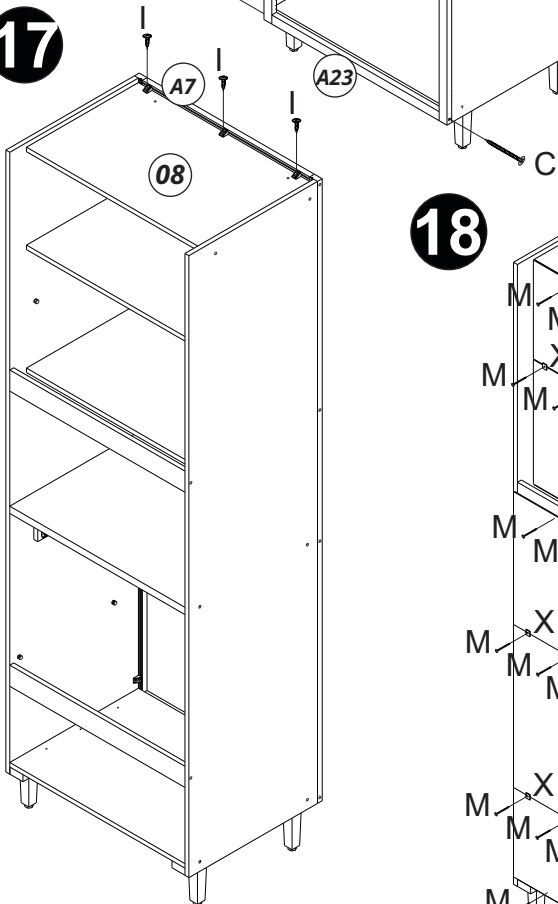

18

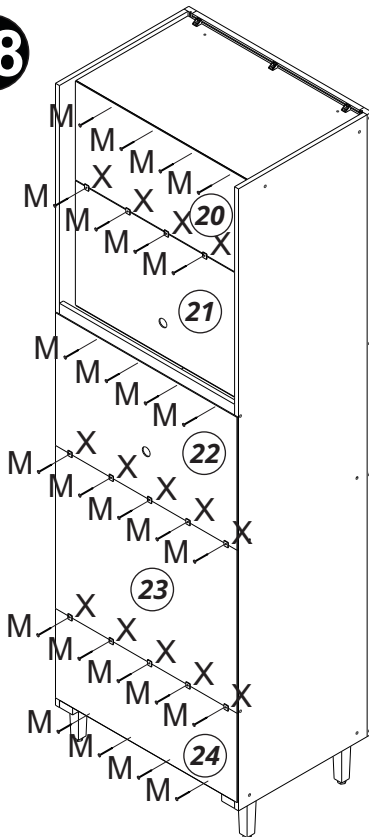

19

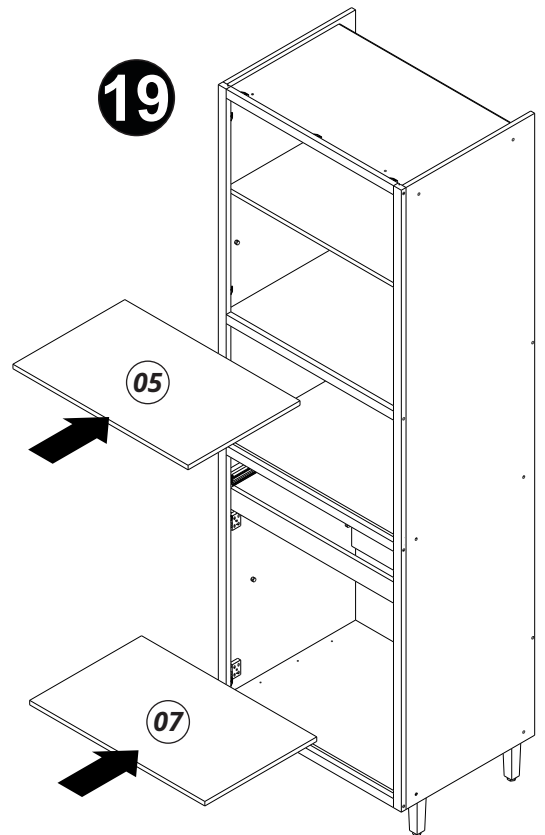

## INSTRUÇÕES

INSTRUCTIONS - INSTRUCCIONES

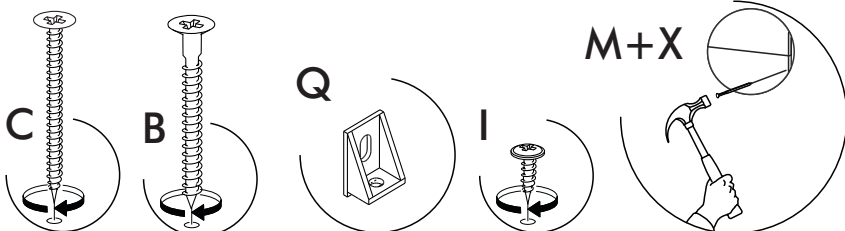

# MONTAGEM

ASSEMBLY - MONTAJE

14

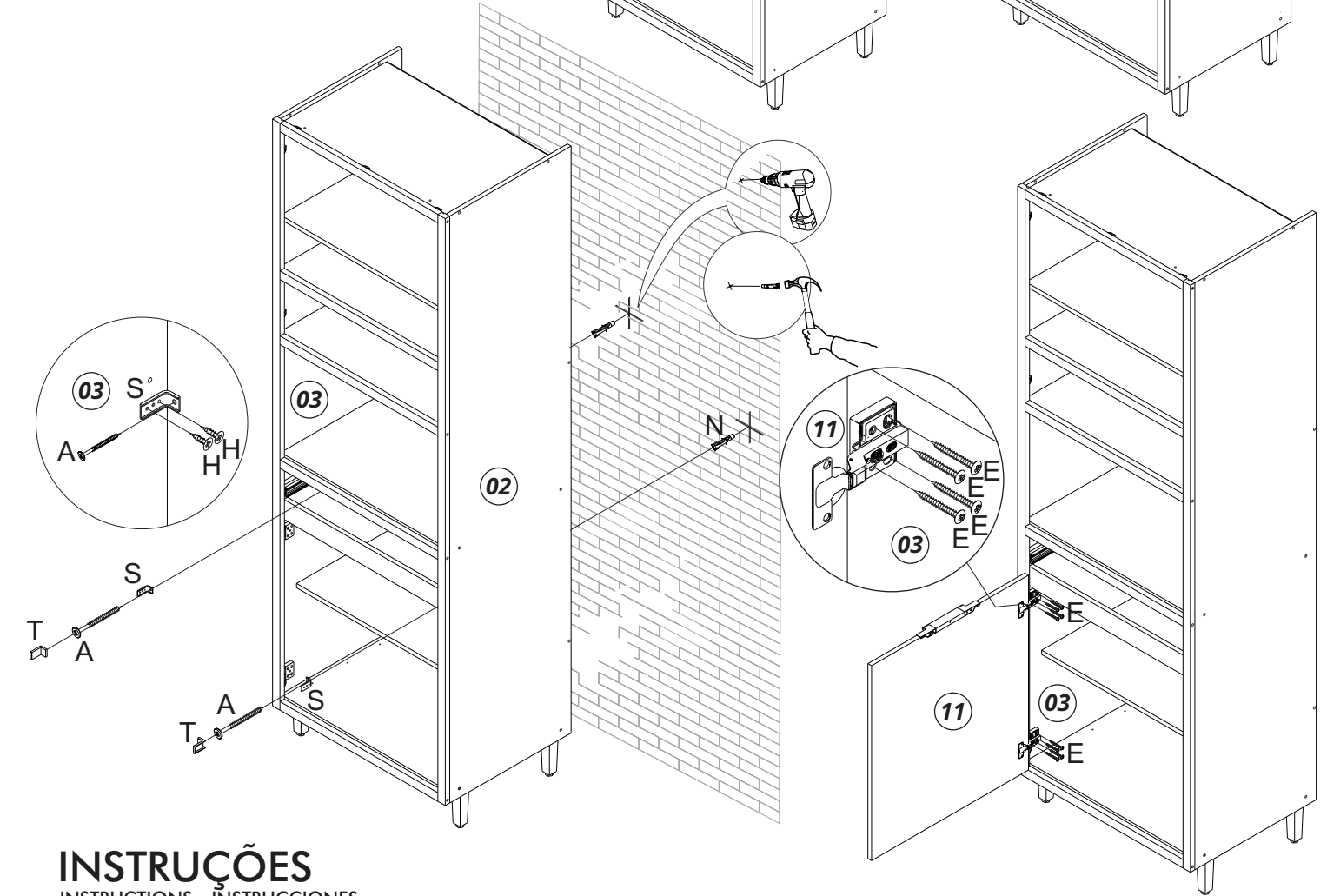
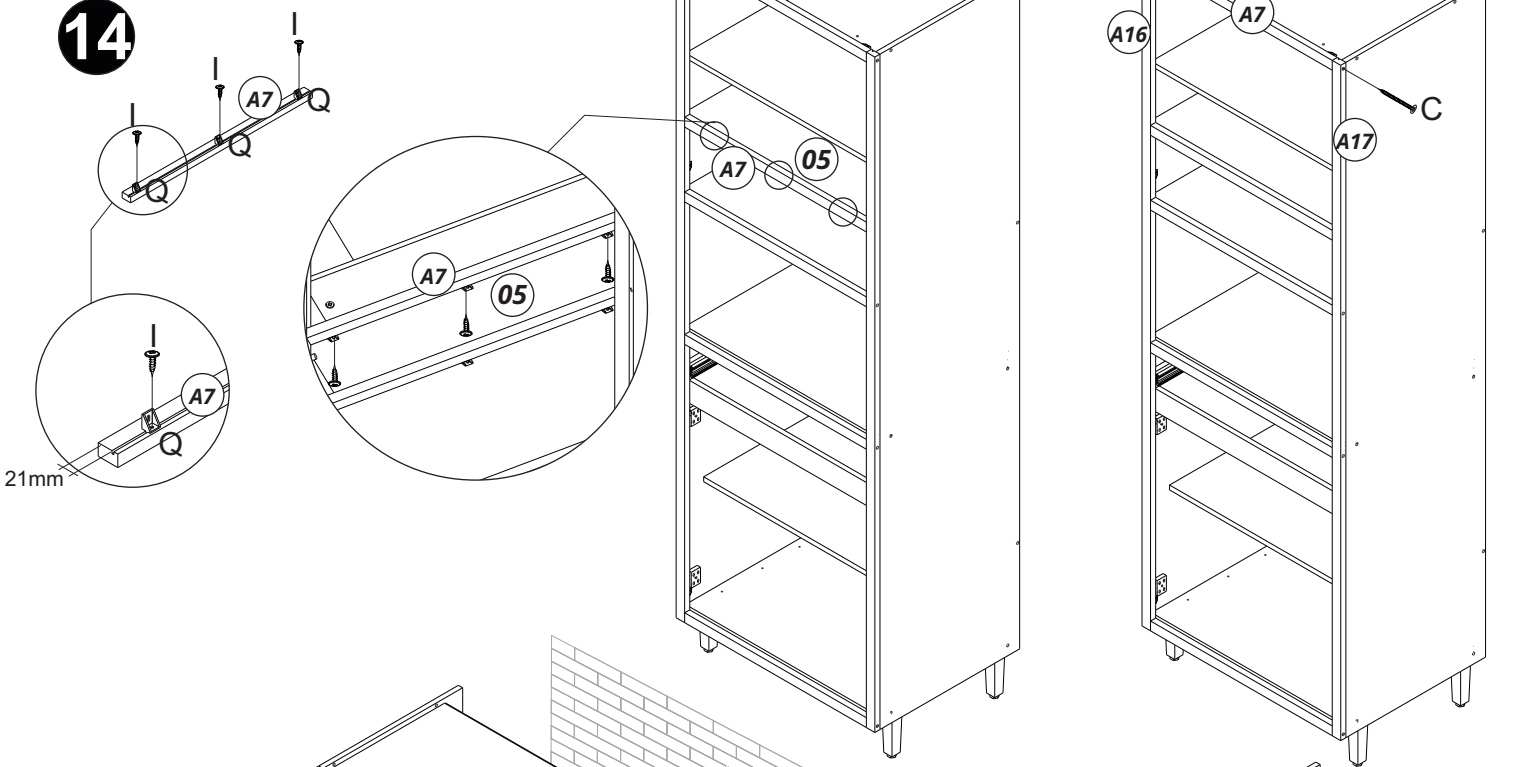

# INSTRUÇÕES

INSTRUCTIONS - INSTRUCCIONES

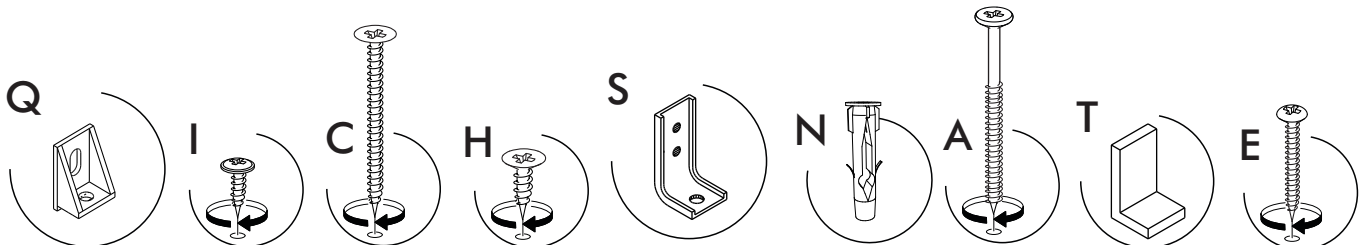

# MONTAGEM

ASSEMBLY - MONTAJE

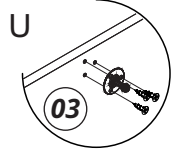
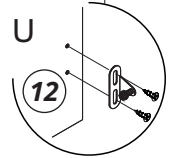
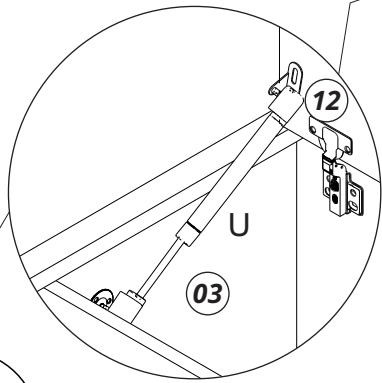
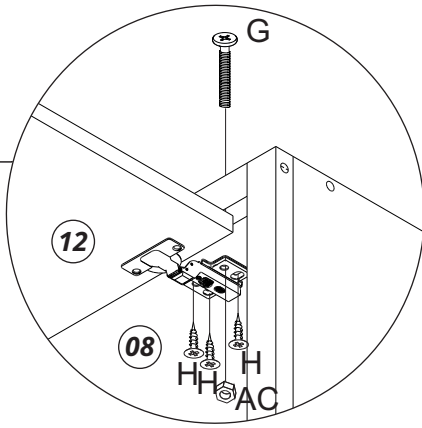
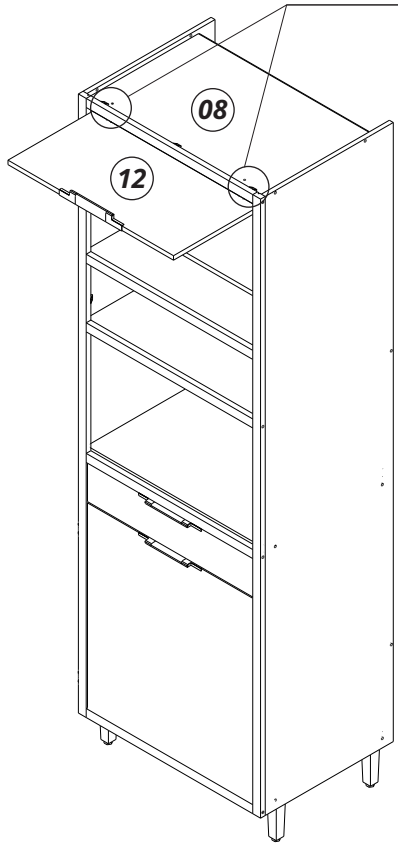
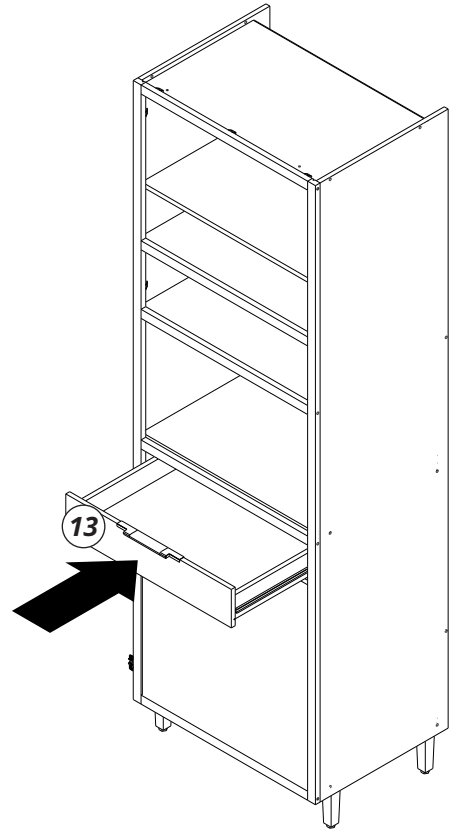
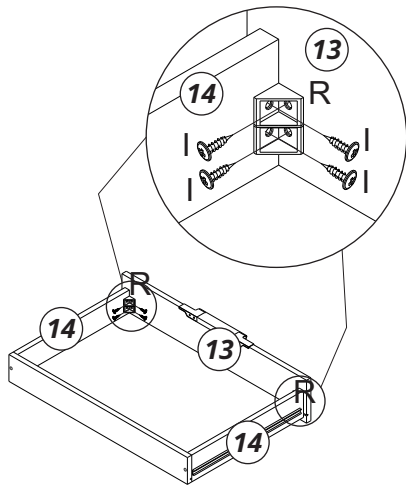
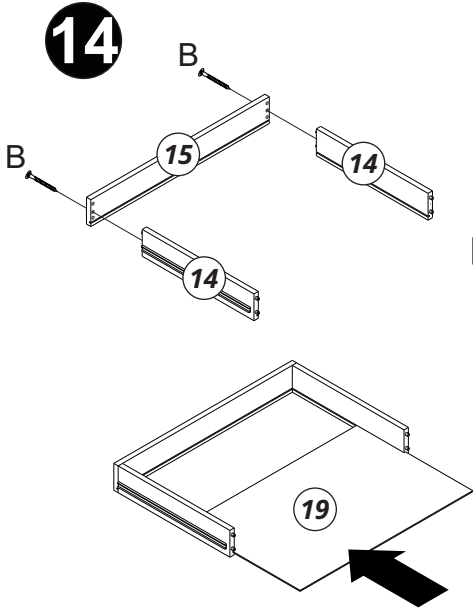

Para a fixação do pistão de amortecimento a porta do armário, siga as furações pré marcadas.  
 For mounting the damping piston on the door of the cabinet follow the holes pre marked.  
 Para montar el pistón de amortiguación en la puerta del gabinete siga los agujeros pre marcado.

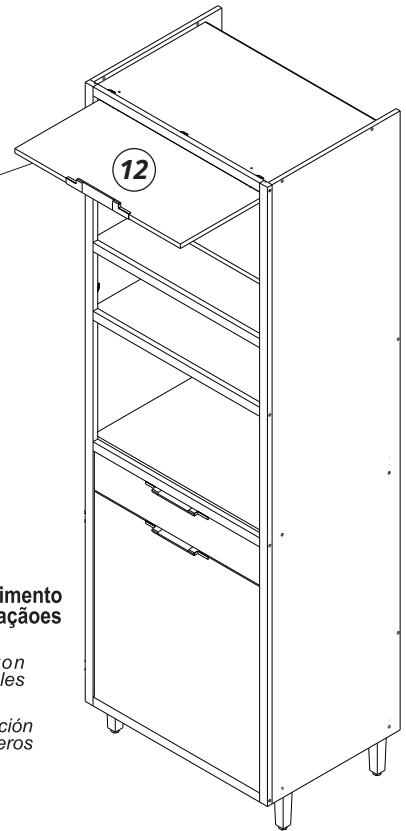

## INSTRUÇÕES

INSTRUCTIONS - INSTRUCCIONES

