

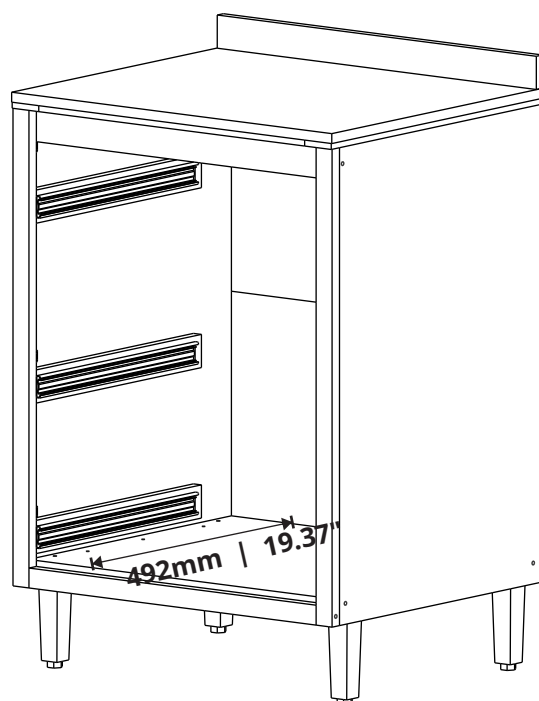

VITAMOV

BALCÃO BARONESA 60 GAVETA BARONESA 60 COUNTER DRAWER ENCIMERA BARONESA 60 CAJÓN

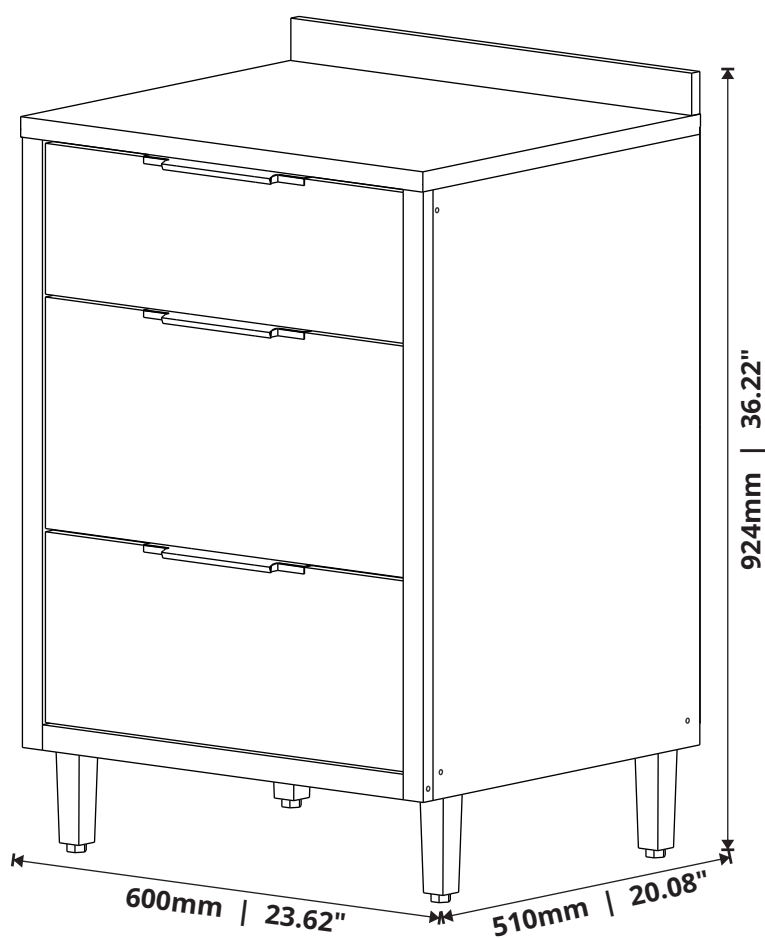

Rua Augusto Zanforlim, 1-25 - Distrito Industrial
CEP: 15520-000, Valentim Gentil/SP - Cx. Postal 18
Fone: (17) 3485-1336
vitamov@vitamov.com.br

ACESSÓRIOS

ACCESSORIES - ACCESORIOS

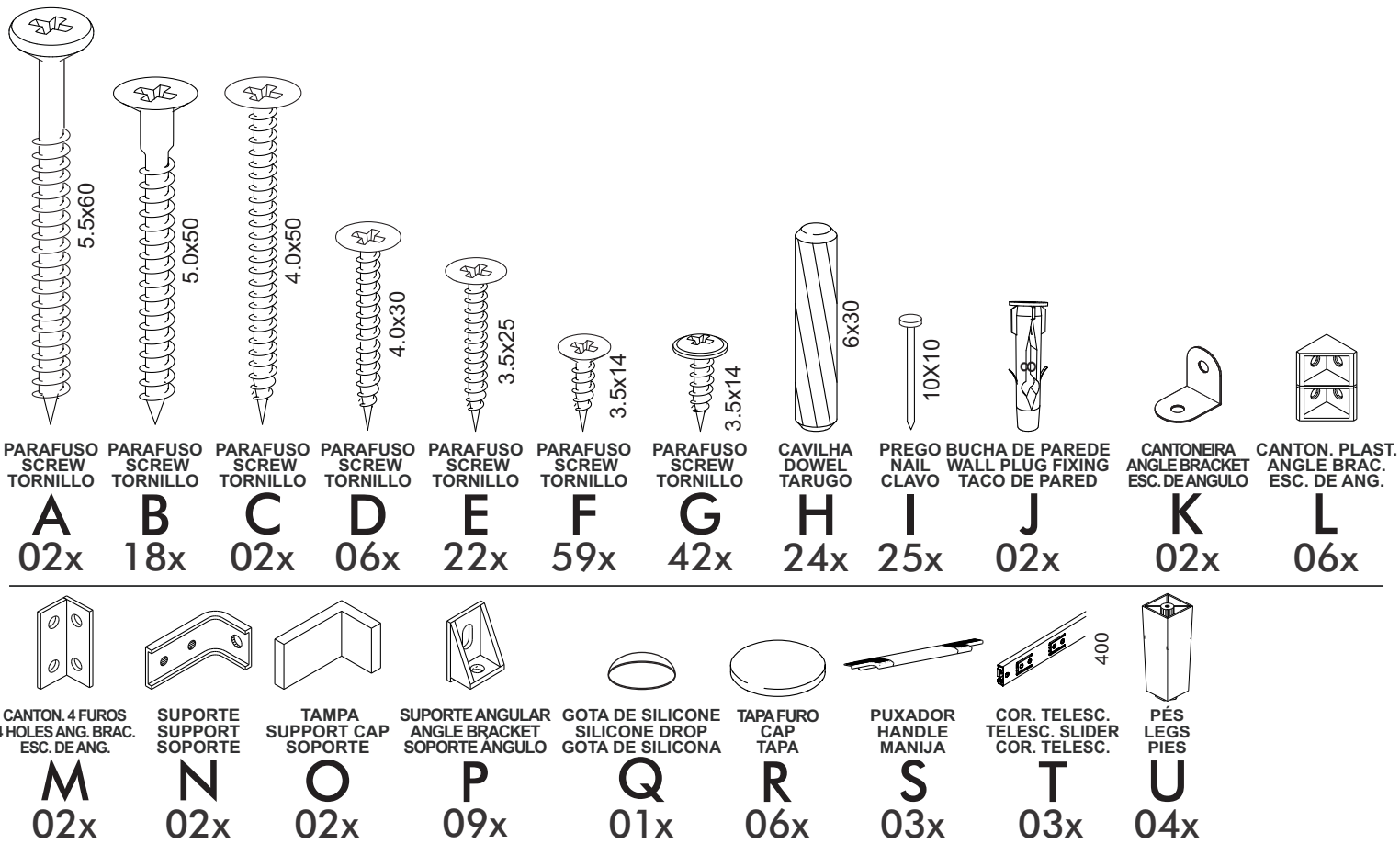

CAPACIDADE DE CARGA

LOAD CAPACITY - CAPACIDAD DE CARGA

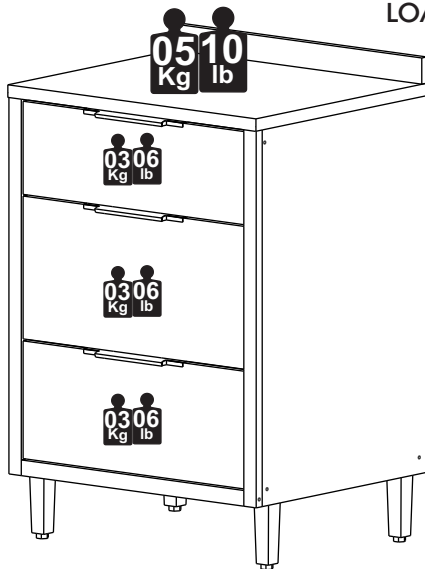

AS FERRAMENTAS NECESSÁRIAS PARA A MONTAGEM DO PRODUTO NÃO SÃO FORNECIDAS PELA EMPRESA.
THE TOOLS NEEDED FOR THE PRODUCT ASSEMBLY ARE NOT PROVIDED BY THE COMPANY.
LAS HERRAMIENTAS NECESARIAS PARA LA EL MONTAJE DEL PRODUCTO NO SON PROPORCIONADO POR LA EMPRESA.

A CAPACIDADE DE CARGA INDICADA É DISTRIBUÍDA NAS ÁREAS DEMONSTRADAS.

THE INDICATED LOAD CAPACITY IS DISTRIBUTED IN THE SHOWN AREAS.

LA CAPACIDAD DE CARGA INDICADA ES DISTRIBUIDA EN ZONAS DEMONSTRADAS.

CERTIFICADO DE GARANTIA

CERTIFICATE OF WARRANTY - CERTIFICADO DE GARANTÍA

DISPOSIÇÕES

O projeto, instalação e a montagem na residência do consumidor não é responsabilidade da Vitamov. A montagem deve seguir corretamente as instruções que se encontram dentro da embalagem de cada módulo.

A Vitamov se reserva o direito de efetuar modificações de caráter técnico em seus produtos, sem aviso prévio.

EXCLUSÃO DA GARANTIA

O presente termo exclui de sua garantia:

- danos causados em consequência de acidentes, mau uso, manuseio ou deslocamento incorreto dos produtos;
- danos causados por montagem inadequada;
- danos em decorrência de agentes externos (inundações, incêndio, etc);
- defeitos oriundos de umidade excessiva

A fixação dos armários de forma segura e garantida depende da qualidade da parede na qual os mesmos serão instalados.

A Vitamov não se responsabiliza por danos causados por instalações dos armários em paredes inadequadas.

PROVISIONS

The design, installation and assembly in the consumer's home is not the responsibility of Vitamov. Assembly must correctly follow the instructions given found inside the packaging of each module. Vitamov reserves the right to make technical changes to its products without prior notice.

EXCLUSION OF WARRANTY

This term excludes from its warranty:

- damage caused as a result of accidents, misuse, incorrect handling or displacement of the products;
- damage caused by improper assembly;
- damage resulting from external agents (floods, fire, etc.);
- defects from excessive humidity. Fixing the cabinets safely and securely depends on the quality of the wall on which they will be installed. Vitamov is not responsible for damage caused by installing cabinets on inadequate walls.

PROVISIONES

El diseño, instalación y montaje en el domicilio del consumidor no es responsabilidad de Vitamov. El montaje debe seguir correctamente las instrucciones dadas que se encuentra dentro del embalaje de cada módulo. Vitamov se reserva el derecho de realizar cambios técnicos en sus productos sin previo aviso.

EXCLUSIÓN DE GARANTÍA

Este certificado excluye de su garantía:

- daños causados como consecuencia de accidentes, mal uso, manejo incorrecto o desplazamiento de los productos;
- daños causados por un montaje inadecuado;
- daños resultantes de agentes externos (inundaciones, incendios, etc.);
- defectos por exceso de humedad. La fijación de los gabinetes de manera segura y segura depende de la calidad de la pared en la que se instalarán.

Vitamov no es responsable de daños causados por instalar gabinetes en paredes inadecuadas.

PEÇAS

PIECES - PIEZAS

Nº PÇ	PORTUGUÊS	ENGLISH	ESPAÑOL	Medidas/Measures/ Medidas	Qtde.	Cod. Assist.
1	Base	Base	Base	570 x 492 x 15	1	4582
2	Lateral Direita	Right Side	Lado Derecho	720 x 492 x 15	1	4581
3	Lateral Esquerda	Left Side	Lado Izquierdo	720 x 492 x 15	1	4599
4	Batente	Flap	Solapa	570 x 50 x 15	1	4596
5	Trava	Frame	Moldura	570 x 70 x 15	1	4597
6	Frente de Gaveta Menor	Smaller Drawer Front	Frente Del Cajón Menor	536 x 178 x 15	1	4588
7	Lateral de Gaveta Menor	Smaller Drawer Side	Lado Del Cajón Menor	385 x 100 x 15	2	4583
8	Contra Fundo de Gaveta Menor	Smaller Counter Bottom	Contra Fondo Del Cajón Menor	515 x 100 x 15	1	4592
9	Frente de Gaveta Central	Center Drawer Front	Frente Del Cajón Central	536 x 273 x 15	1	4585
10	Lateral de Gaveta Central	Center Drawer Side	Lado Del Cajón Central	385 x 150 x 15	2	4594
11	Contra Fundo de Gaveta Central	Center Counter Bottom	Contra Fondo Del Cajón Central	515 x 150 x 15	1	4589
12	Frente de Gaveta Inferior	Bottom Drawer Front	Frente Del Cajón Inferior	536 x 225 x 15	1	4586
13	Lateral de Gaveta Inferior	Bottom Drawer Side	Lado Del Cajón Inferior	385 x 150 x 15	2	4593
14	Contra Fundo de Gaveta Inferior	Under Counter Bottom	Contra Fondo Del Cajón Inferior	515 x 150 x 15	1	4590
15	Suporte para Corrediça	Slider Support	Soporte Corredera	400 x 50 x 15	6	4591
16	Régua do Tampo	Top Frame	Moldura Tapa	600 x 50 x 15	1	4595
17	Tampo do Balcão	Counter Top	Tapa Encimera	602 x 512 x 24	1	4584
18	Suporte Pé Lateral	Side Leg Support	Soporte Pié Lado	491 x 50 x 24	2	4587
19	Fundo de Gaveta	Drawer Back	Fondo Del Cajón	495 x 395 x 03	3	4600
20	Fundo Traseiro	Back Panel	Fondo Trasero	596 x 353 x 03	2	4601
A12	Moldura Lateral Esquerda	Left Side Frame	Moldura Lado Izquierdo	720 - Canal 21	1	4546
A21	Moldura Lateral Direita	Right Side Frame	Moldura Lado Derecho	720 - Canal 21	1	4547
A9	Moldura Inferior	Bottom Frame	Moldura Inferior	542 - Canal 16	1	4523

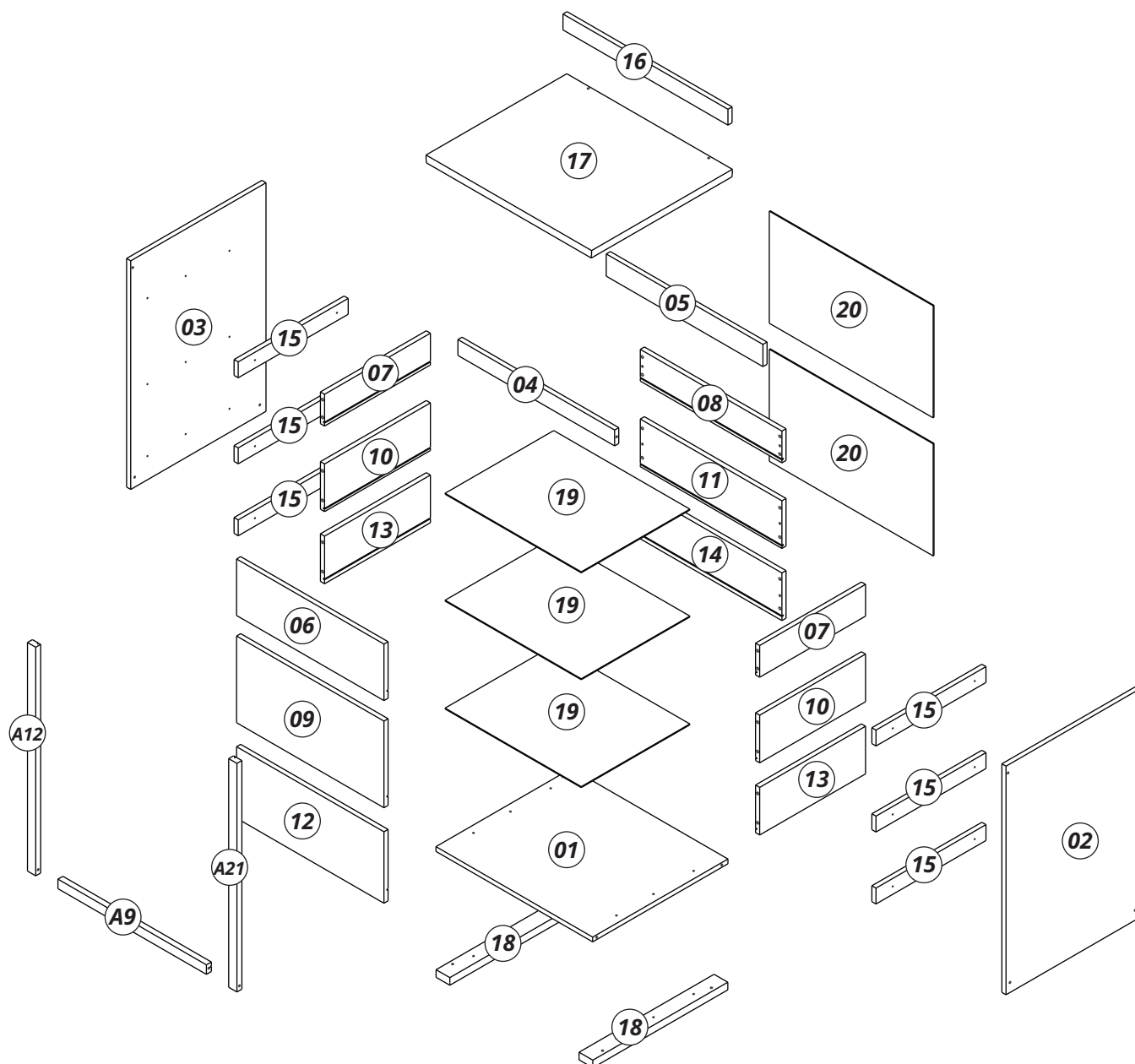

PRÉ-MONTAGEM

PRE ASSEMBLY - PRÉ-MONTAJE

IMPORTANT ATTENTION - IMPORTANTE
 A MONTAGEM DEVE SER REALIZADA POR UM PROFISSIONAL DE MONTAGEM.
 ASSEMBLY MUST BE CARRIED OUT BY AN ASSEMBLY PROFESSIONAL.
 EL MONTAJE DEBE SER HECHO POR UN MONTADOR DE MUEBLES.

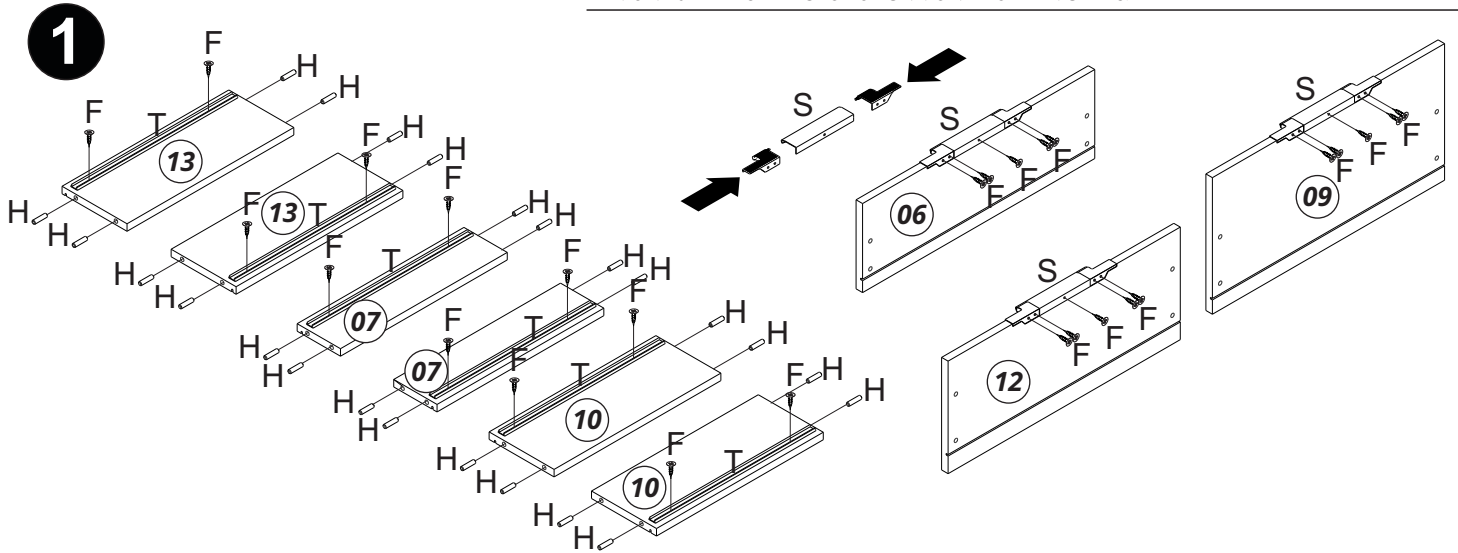

MONTAGEM

ASSEMBLY - MONTAJE

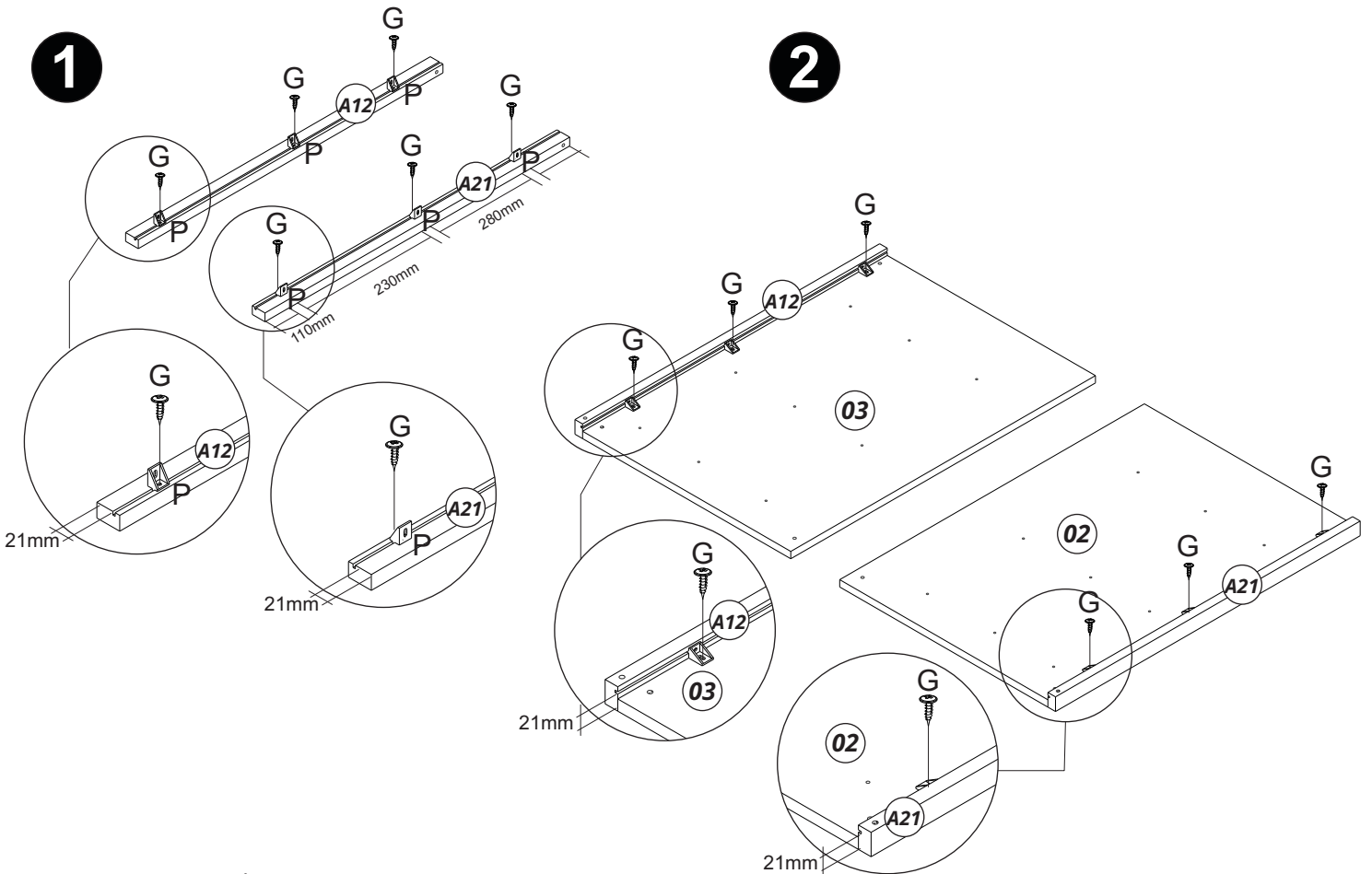

INSTRUÇÕES

INSTRUCTIONS - INSTRUCCIONES

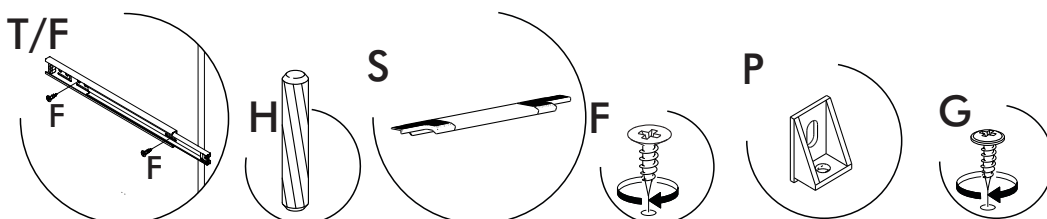

MONTAGEM

ASSEMBLY - MONTAJE

3

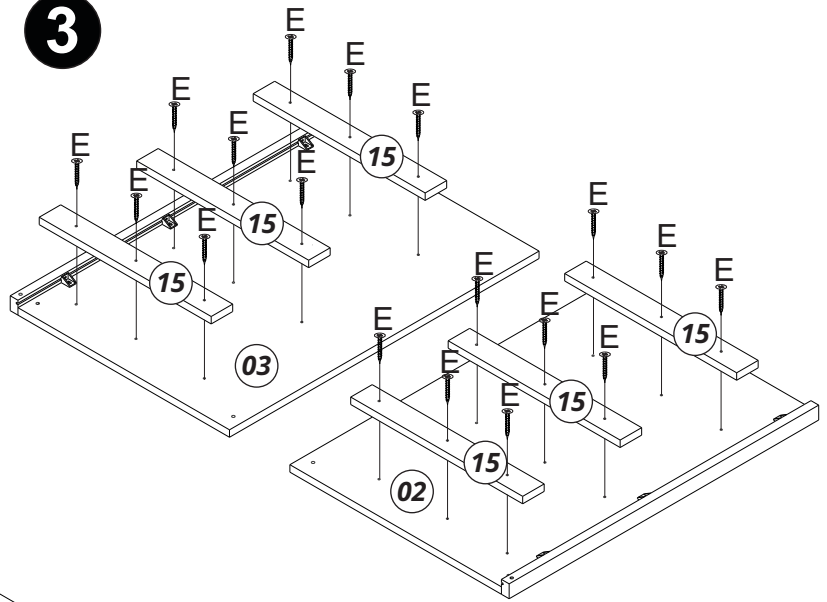

4

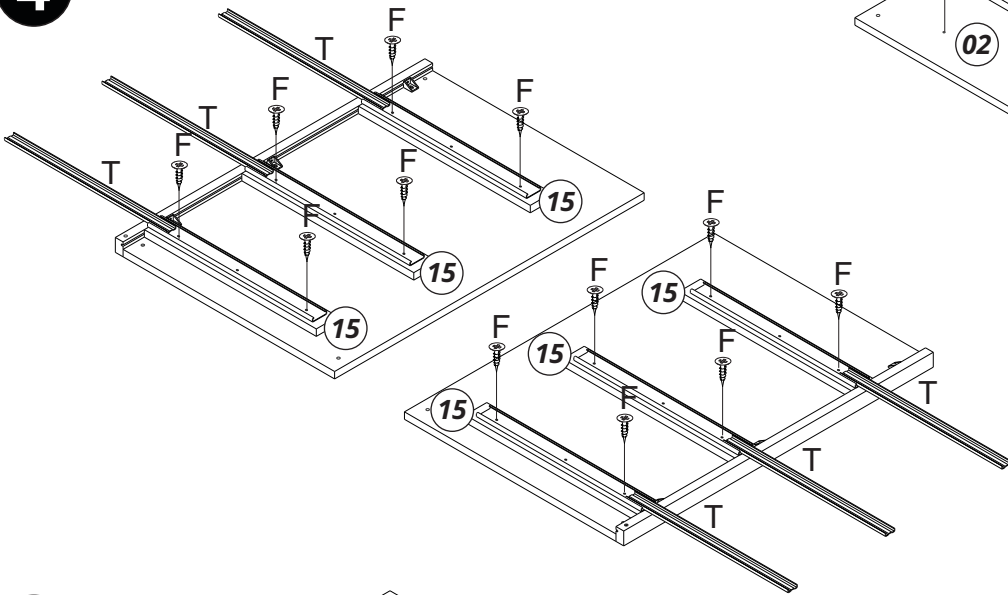

5

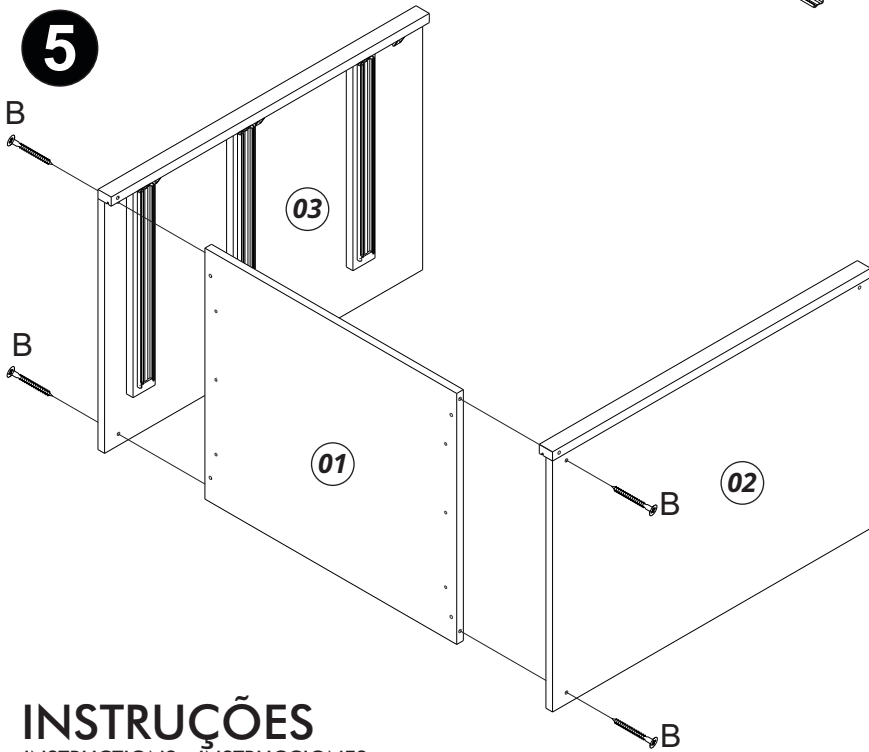

6

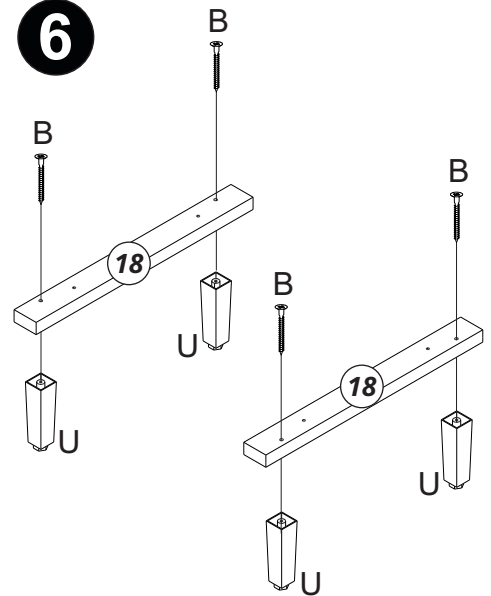

INSTRUÇÕES

INSTRUCTIONS - INSTRUCCIONES

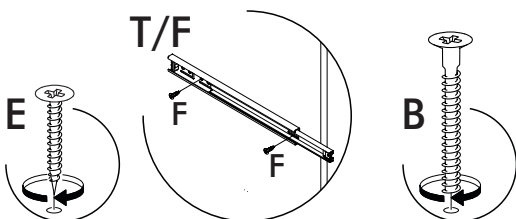

MONTAGEM

ASSEMBLY - MONTAJE

7

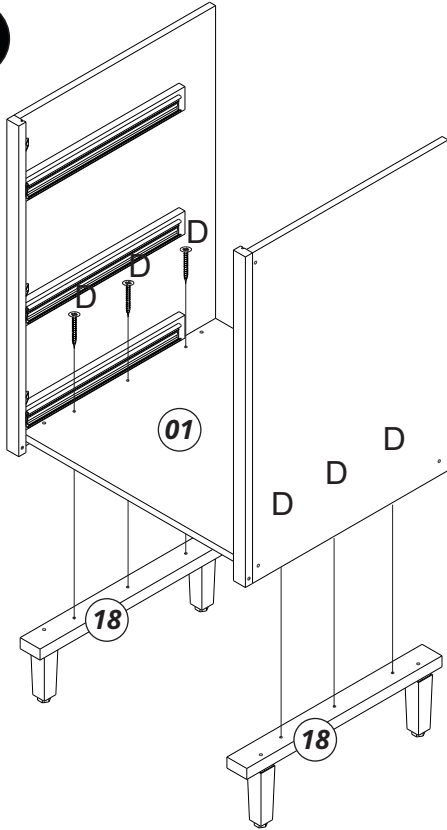

8

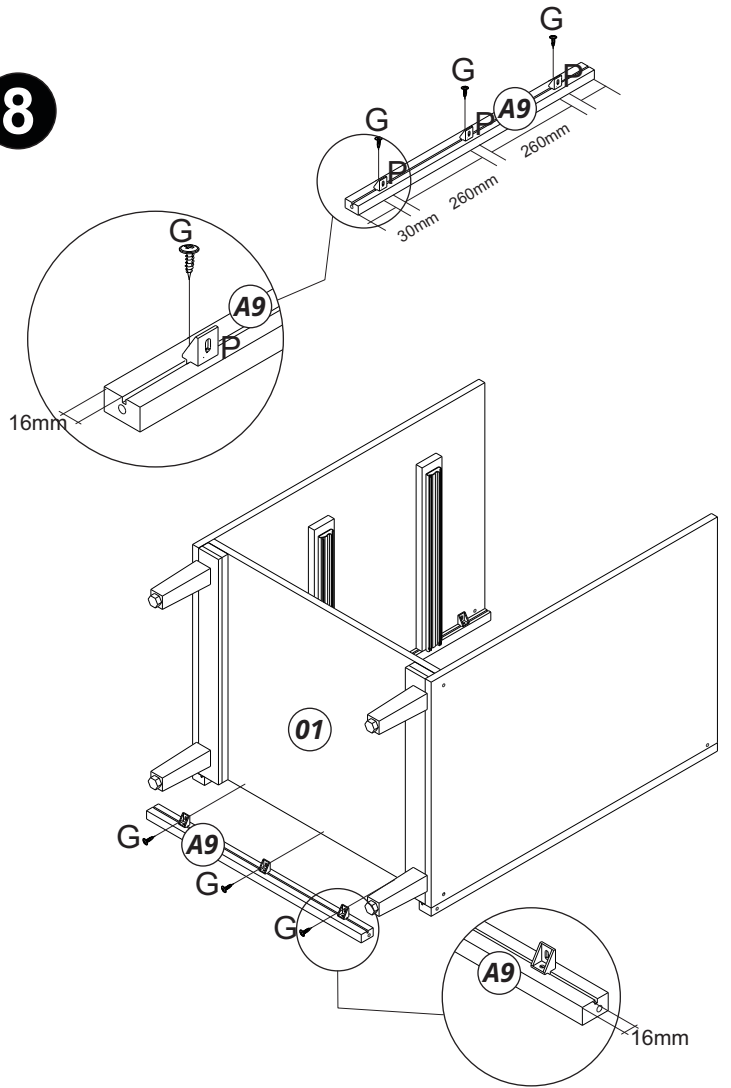

9

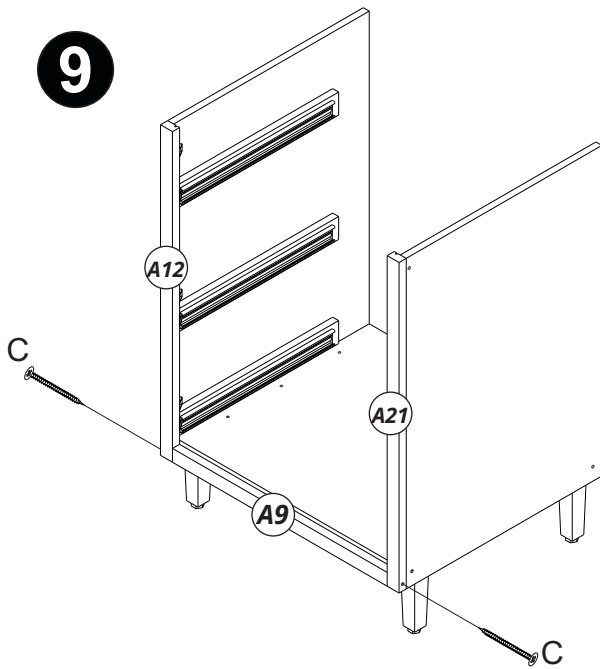

10

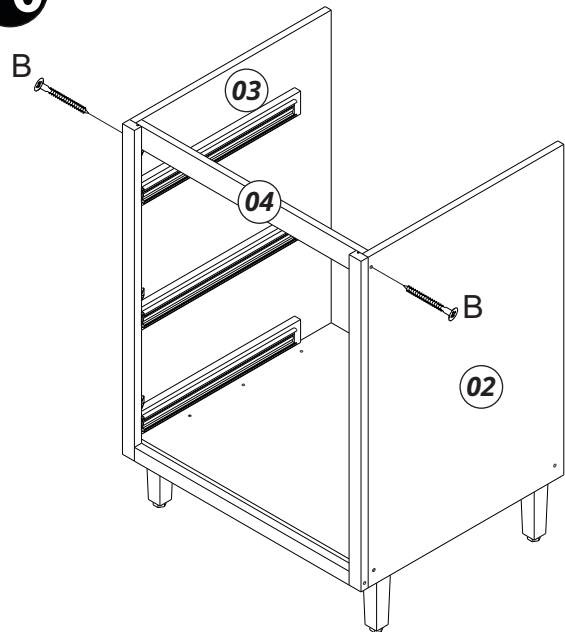

INSTRUÇÕES

INSTRUCTIONS - INSTRUCCIONES

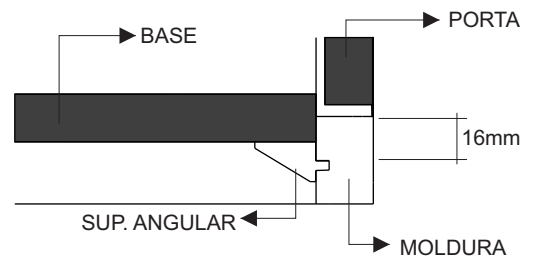
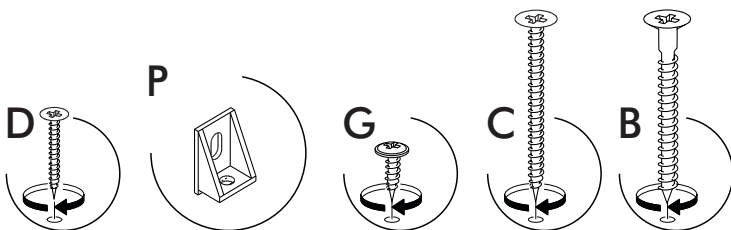

MONTAGEM

ASSEMBLY - MONTAJE

11

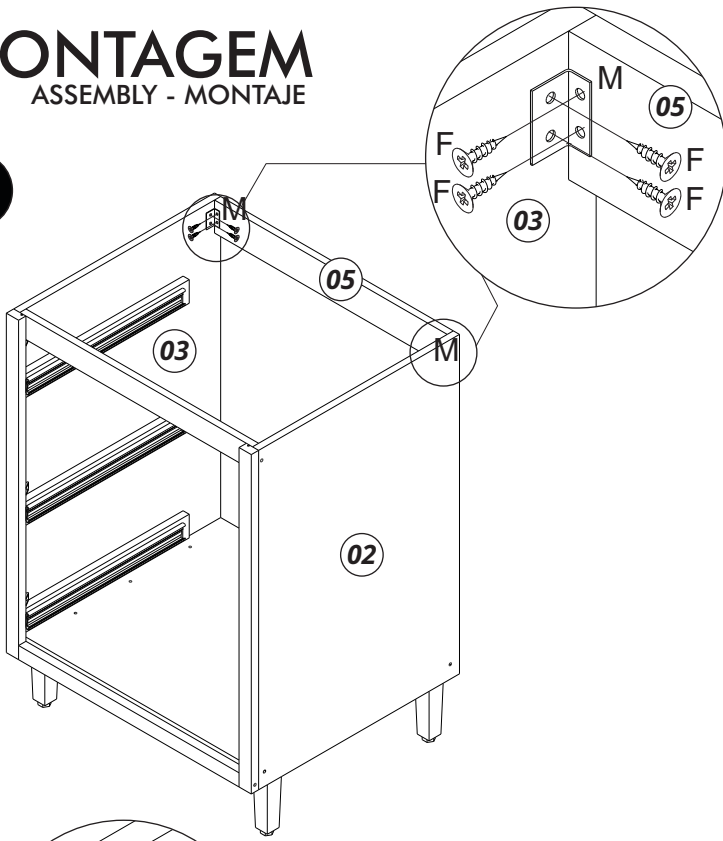

12

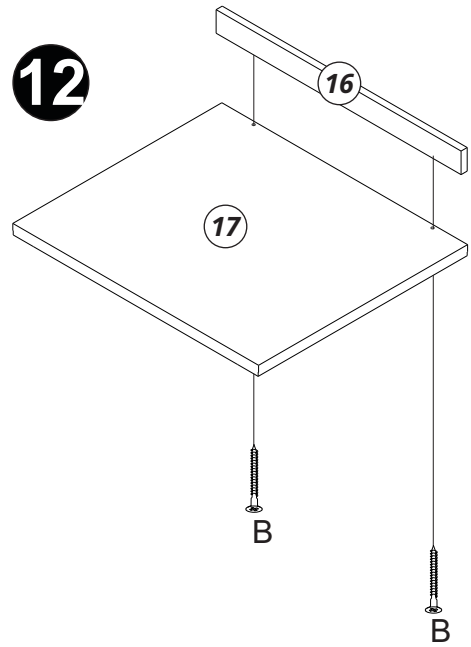

13

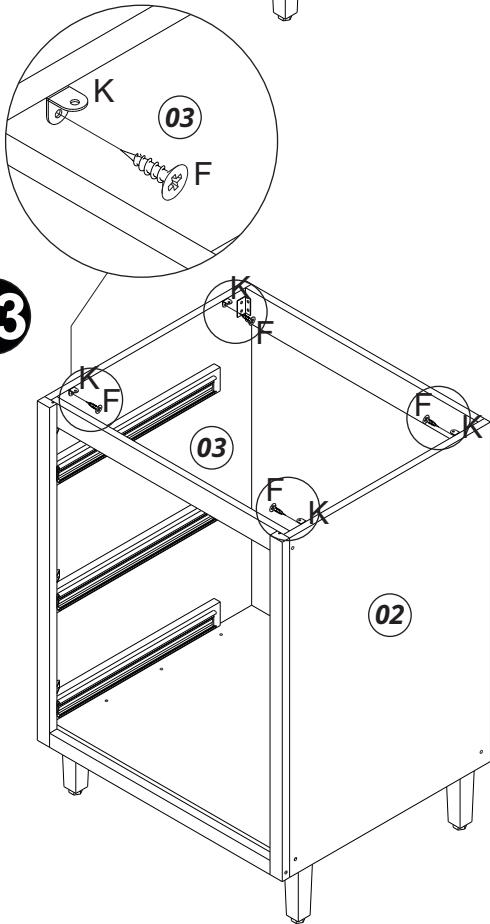

14

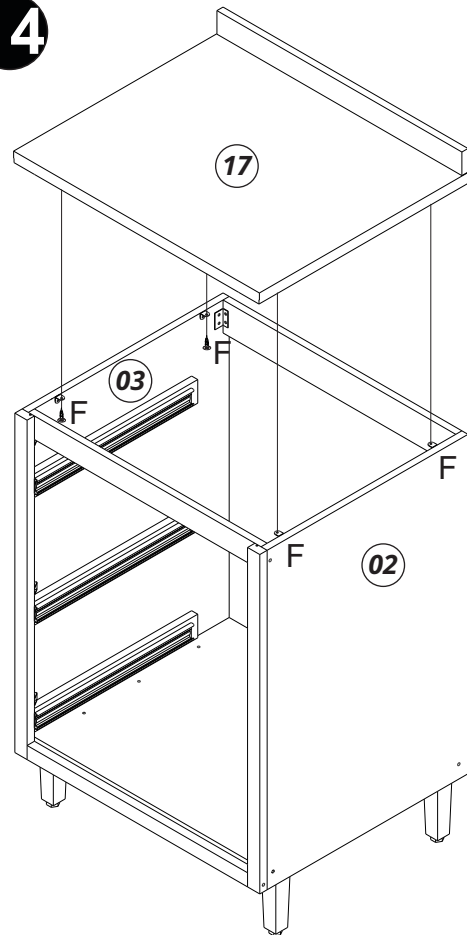

INSTRUÇÕES

INSTRUCTIONS - INSTRUCCIONES

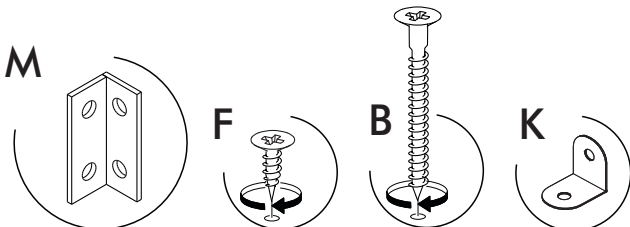

MONTAGEM

ASSEMBLY - MONTAJE

15

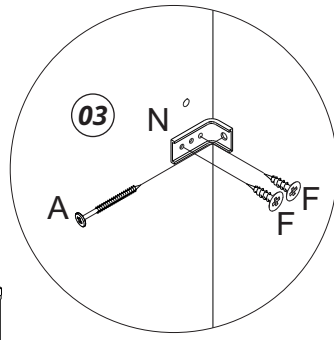
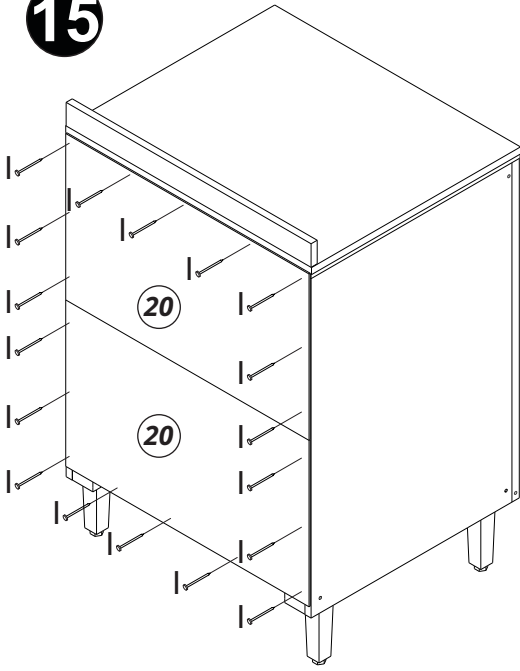

16

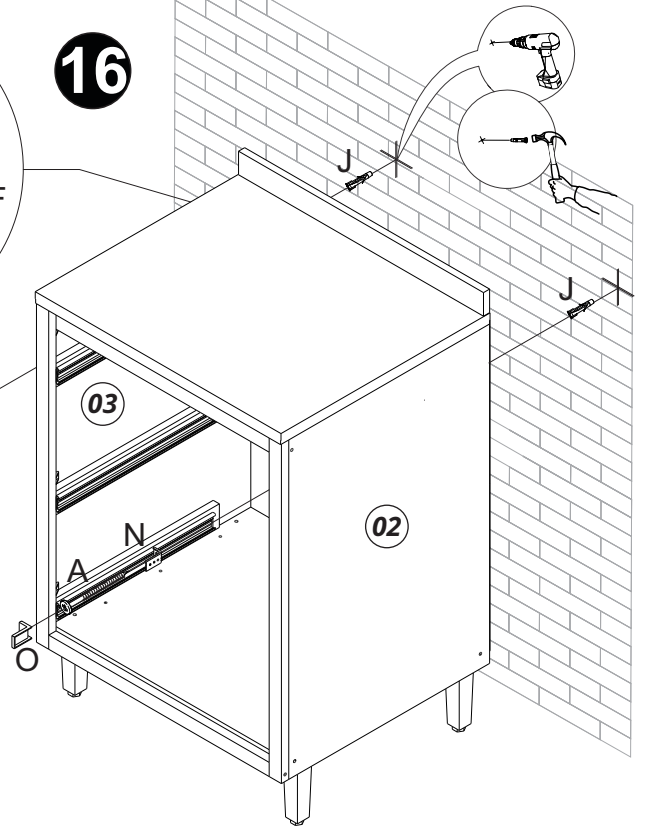
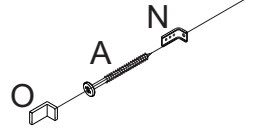

17

Repetir o passo 17 para a montagem das 3 gavetas.
Repeat step 17 to assemble the 3 drawers.
Repita el paso 17 para ensamblar los 3 cajones.

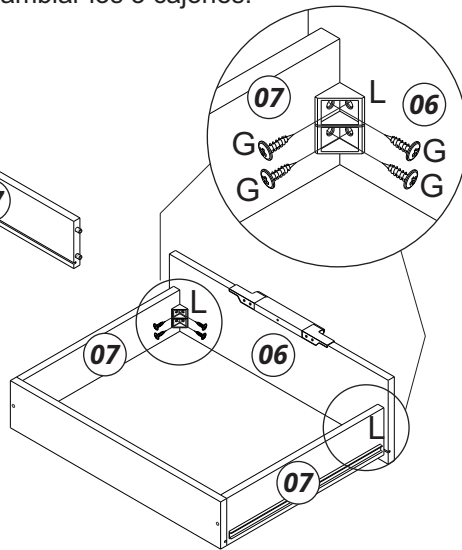
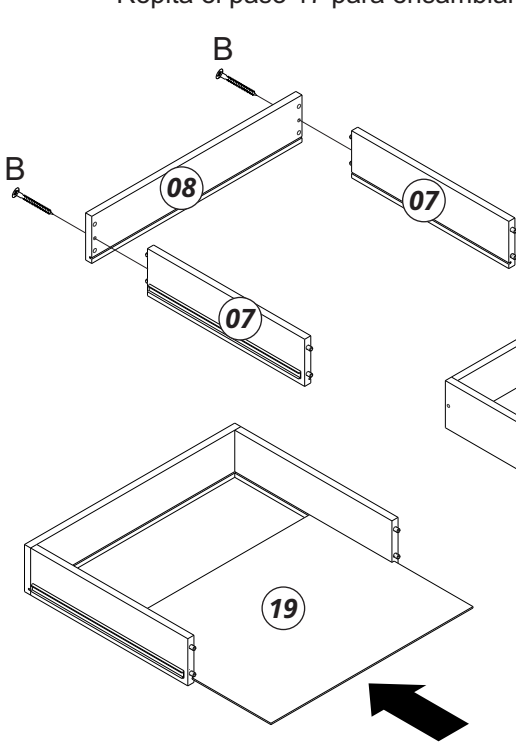

18

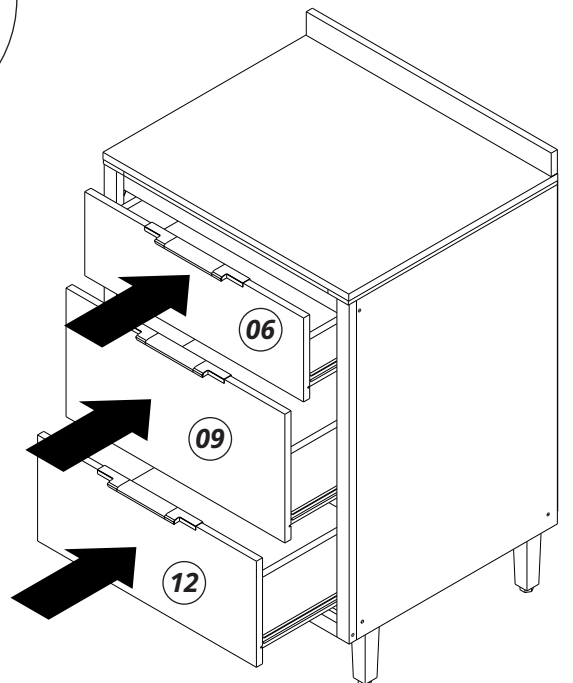

INSTRUÇÕES

INSTRUCTIONS - INSTRUCCIONES

