

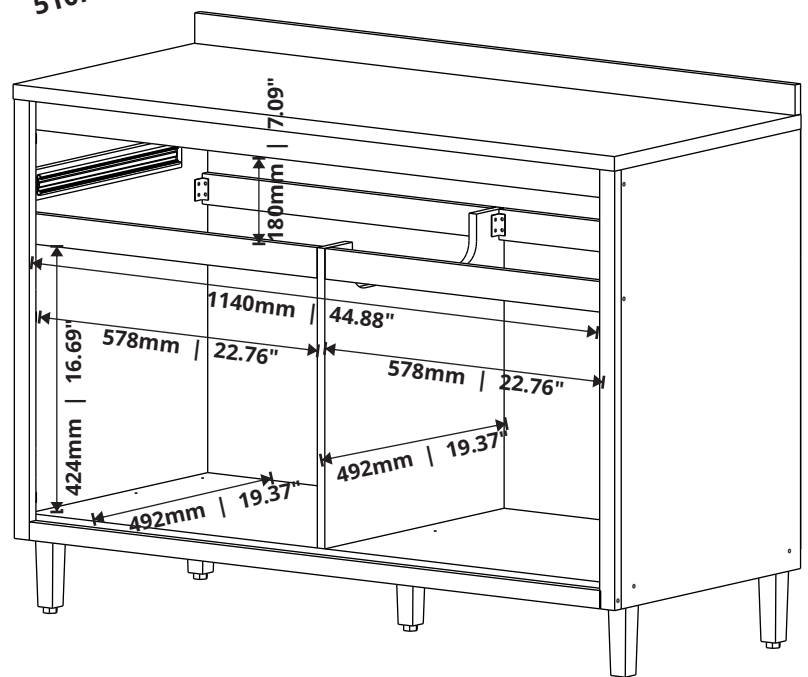

# VITAMOV

## BALCÃO BARONESA 120 BARONESA 120 COUNTER ENCIMERA BARONESA 120

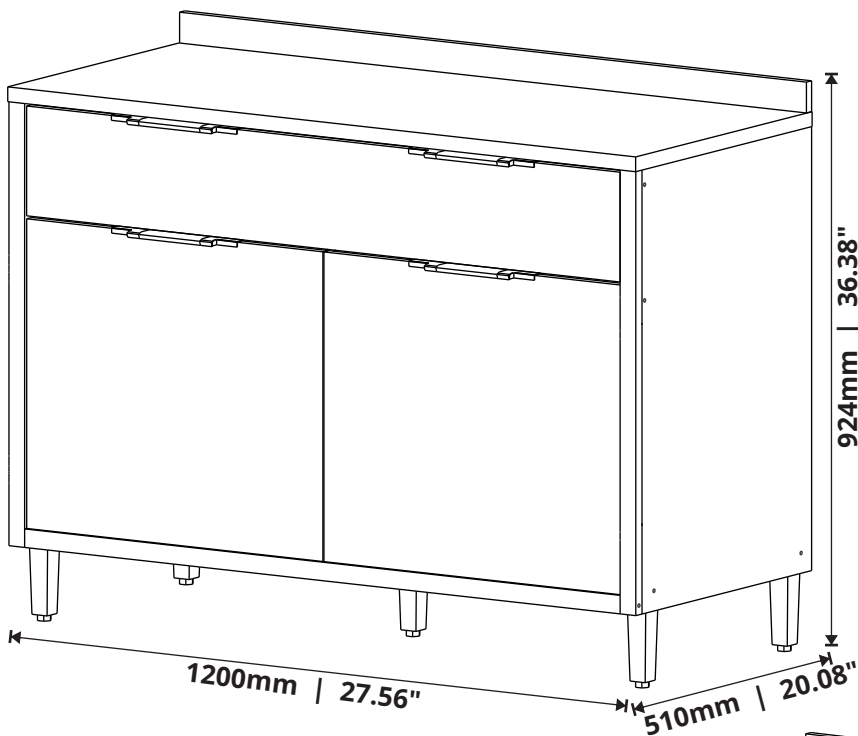

Rua Augusto Zanforlim, 1-25 - Distrito Industrial  
CEP: 15520-000, Valentim Gentil/SP - Cx. Postal 18  
Fone: (17) 3485-1336  
vitamov@vitamov.com.br

# ACESSÓRIOS

ACCESSORIES - ACCESORIOS

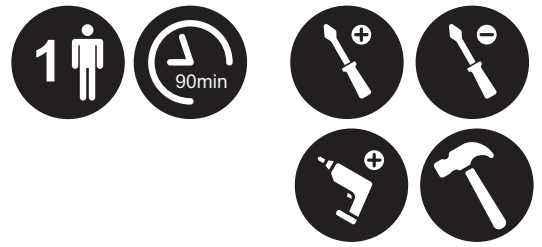
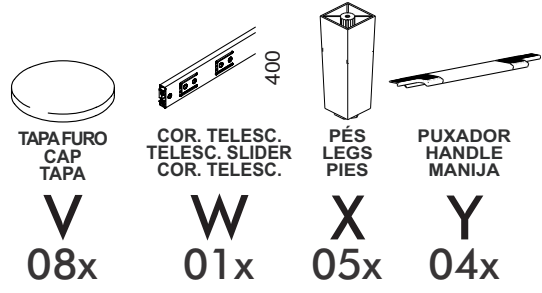
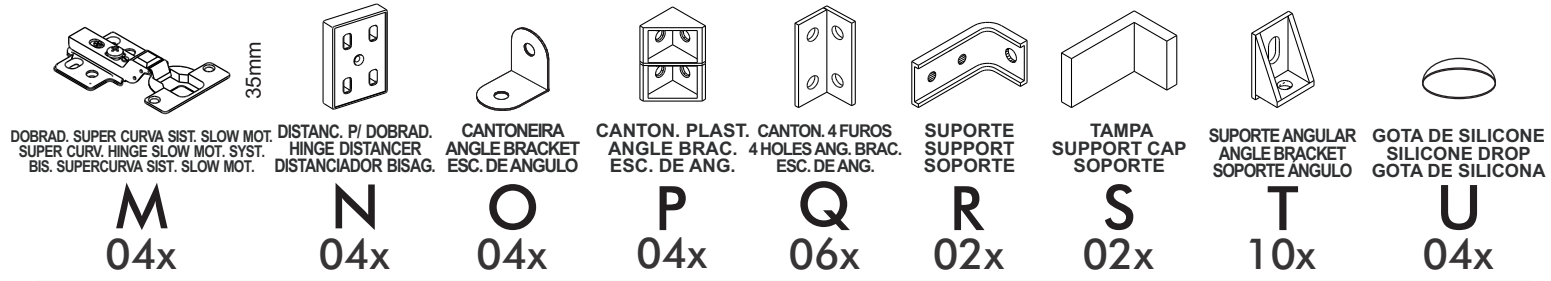
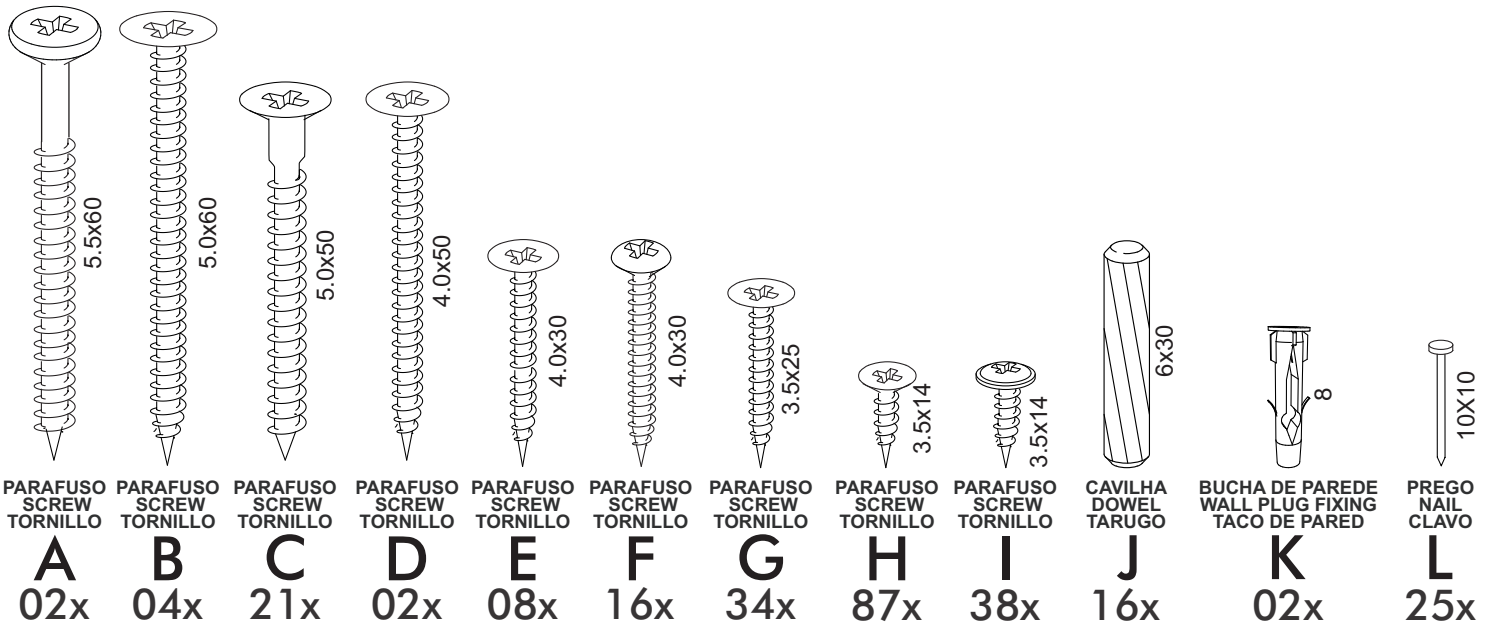

## CAPACIDADE DE CARGA

LOAD CAPACITY - CAPACIDAD DE CARGA

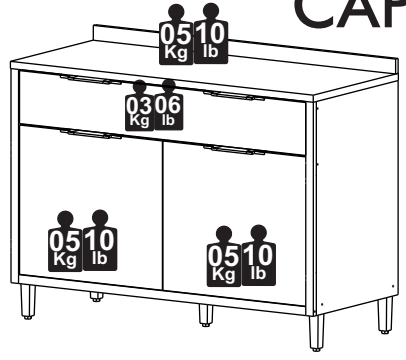

A CAPACIDADE DE CARGA INDICADA É DISTRIBUÍDA NAS ÁREAS DEMONSTRADAS.  
 THE INDICATED LOAD CAPACITY IS DISTRIBUTED IN THE SHOWN AREAS.  
 LA CAPACIDAD DE CARGA INDICADA ES DISTRIBUIDA EN ZONAS DEMONSTRADAS.

AS FERRAMENTAS NECESSÁRIAS PARA A MONTAGEM DO PRODUTO NÃO SÃO FORNECIDAS PELA EMPRESA.  
 THE TOOLS NEEDED FOR THE PRODUCT ASSEMBLY ARE NOT PROVIDED BY THE COMPANY.  
 LAS HERRAMIENTAS NECESARIAS PARA LA EL MONTAJE DEL PRODUCTO NO SON PROPORCIONADO POR LA EMPRESA.

## CERTIFICADO DE GARANTIA

CERTIFICATE OF WARRANTY - CERTIFICADO DE GARANTÍA

**DISPOSIÇÕES**  
 O projeto, instalação e a montagem na residência do consumidor não é responsabilidade da Vitamov. A montagem deve seguir corretamente as instruções que se encontram dentro da embalagem de cada módulo.  
 A Vitamov se reserva o direito de efetuar modificações de caráter técnico em seus produtos, sem aviso prévio.  
**EXCLUSÃO DA GARANTIA**  
 O presente termo exclui de sua garantia:  
 - danos causados em consequência de acidentes, mau uso, manuseio ou deslocamento incorreto dos produtos;  
 - danos causados por montagem inadequada;  
 - danos em decorrência de agentes externos (inundações, incêndio, etc);  
 - defeitos oriundos de umidade excessiva  
 A fixação dos armários de forma segura e garantida depende da qualidade da parede na qual os mesmos serão instalados. A Vitamov não se responsabiliza por danos causados por instalações dos armários em paredes inadequadas.

**PROVISIONS**  
 The design, installation and assembly in the consumer's home is not the responsibility of Vitamov. Assembly must correctly follow the instructions given found inside the packaging of each module. Vitamov reserves the right to make technical changes to its products without prior notice.  
**EXCLUSION OF WARRANTY**  
 This term excludes from its warranty:  
 - damage caused as a result of accidents, misuse, incorrect handling or displacement of the products;- damage caused by improper assembly;  
 - damage resulting from external agents (floods, fire, etc.);  
 - defects from excessive humidity. Fixing the cabinets safely and securely depends on the quality of the wall on which they will be installed. Vitamov is not responsible for damage caused by installing cabinets on inadequate walls.

**PROVISIONES**  
 El diseño, instalación y montaje en el domicilio del consumidor no es responsabilidad de Vitamov. El montaje debe seguir correctamente las instrucciones dadas que se encuentra dentro del embalaje de cada módulo. Vitamov se reserva el derecho de realizar cambios técnicos en sus productos sin previo aviso.  
**EXCLUSIÓN DE GARANTÍA**  
 Este certificado excluye de su garantía:  
 - daños causados como consecuencia de accidentes, mal uso, manejo incorrecto o desplazamiento de los productos;  
 - daños causados por un montaje inadecuado;  
 - daños resultantes de agentes externos (inundaciones, incendios, etc.);  
 - defectos por exceso de humedad. La fijación de los gabinetes de manera segura y segura depende de la calidad de la pared en la que se instalarán.  
 Vitamov no es responsable de daños causados por instalar gabinetes en paredes inadecuadas.

# PEÇAS

PIECES - PIEZAS

Nº PÇ	PORTUGUÊS	ENGLISH	ESPAÑOL	Medidas/Measures/ Medidas	Qtde.	Cod. Assist.
1	Base	Base	Base	1170 x 492 x 15	1	4552
2	Lateral Direita	Right Side	Lado Derecho	720 x 492 x 15	1	4549
3	Lateral Esquerda	Left Side	Lado Izquierdo	720 x 492 x 15	1	4550
4	Divisória	Partition	Partición	492 x 492 x 15	1	4560
5	Porta	Door	Puerta	567 x 502 x 15	2	4558
6	Frente de Gaveta	Drawer Front	Frente Del Cajón	1136 x 178 x 15	1	4559
7	Lateral de Gaveta	Drawer Side	Lado Del Cajón	385 x 100 x 15	4	4562
8	Contra Fundo (Tampo)	Counter Bottom (Top)	Contra Fondo (Tapa)	1115 x 100 x 15	1	4555
9	Contra Fundo (Pia)	Counter Bottom (Sink)	Contra Fondo (Fregadero)	326 x 100 x 15	2	4561
10	Batente de Gaveta Traseiro	Back Drawer Flap	Solapa Del Cajón Trasero	1170 x 50 x 15	1	4554
11	Batente de Porta 1	Door Flap 1	Solapa Puerta 1	577 x 50 x 15	2	4556
12	Batente de Porta 2	Door Flap 2	Solapa Puerta 2	577 x 70 x 15	2	4557
13	Régua do Tampo	Top Frame	Moldura Tapa	1200 x 50 x 15	1	4553
14	Suporte para Corrediça	Slider Support	Soporte Corredera	400 x 50 x 15	2	4563
15	Tampo do Balcão	Counter Top	Tapa Encimera	1202 x 512 x 24	1	4551
16	Suporte Pé Lateral	Leg Side Support	Soporte Pié Lado	491 x 50 x 24	2	4564
17	Suporte Pé Central	Leg Center Support	Soporte Pié Central	140 x 140 x 24	1	4565
18	Fundo de Gaveta p/ Pia	Drawer Back (Sink)	Fondo Del Cajón (Fregadero)	1113 x 405 x 06	1	4567
19	Fundo de Gaveta p/ Tampo	Drawer Back (Top)	Fondo Del Cajón (Tapa)	1113 x 405 x 06	1	4568
20	Fundo 1	Back Panel 1	Fondo 1	1196 x 480 x 03	1	
21	Fundo 2	Back Panel 2	Fondo 2	1196 x 225 x 03	1	
22	Sarrafo de Madeira	Wooden Lath	Listón de Madera	1170 x 40 x 20	1	
A12	Moldura Lateral Esquerda	Left Side Frame	Moldura Lado Izquierdo		1	4546
A21	Moldura Lateral Direita	Right Side Frame	Moldura Lado Derecho		1	4547
A22	Moldura Inferior	Bottom Frame	Moldura Inferior		1	4548

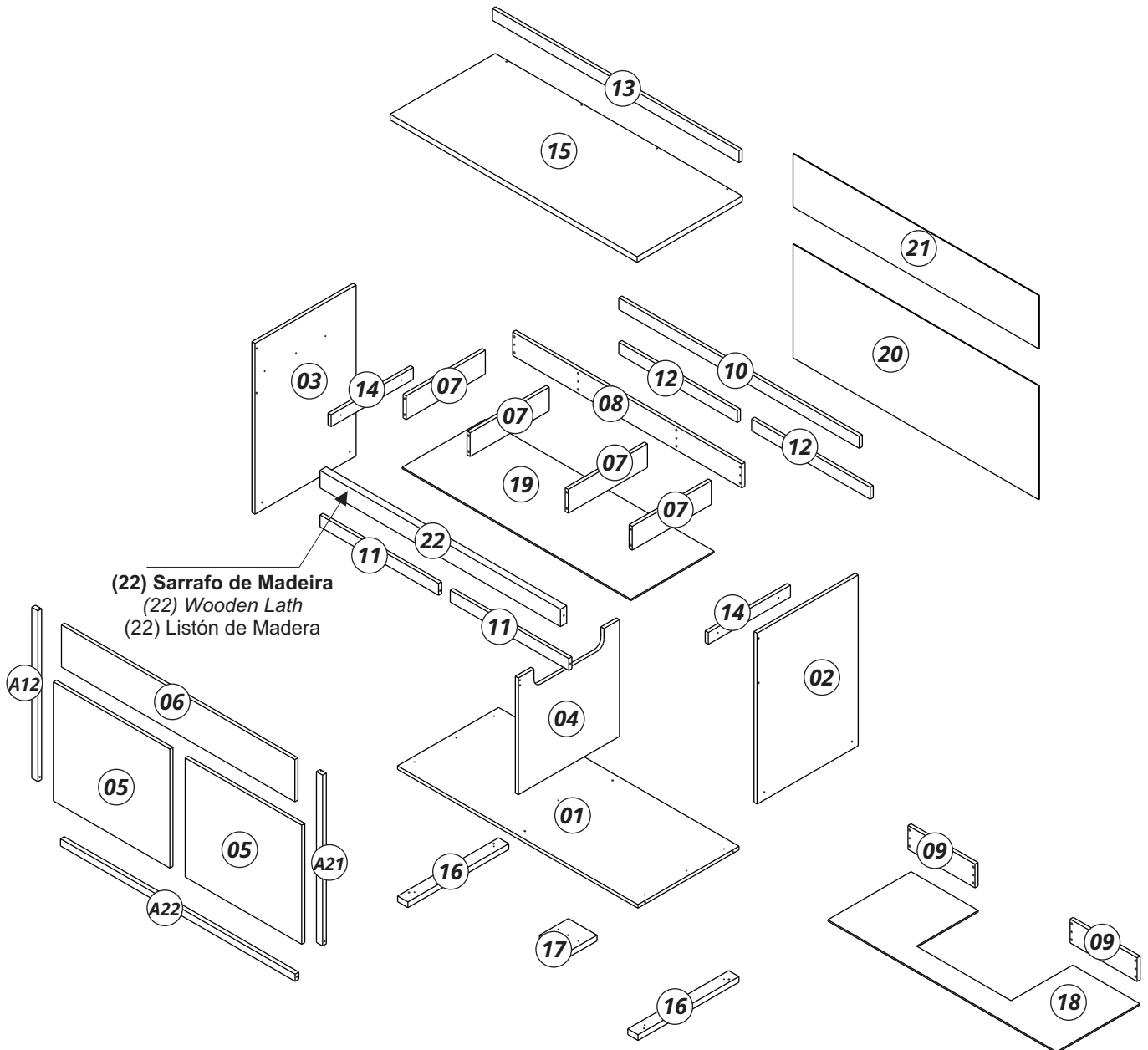



# MONTAGEM

ASSEMBLY - MONTAJE

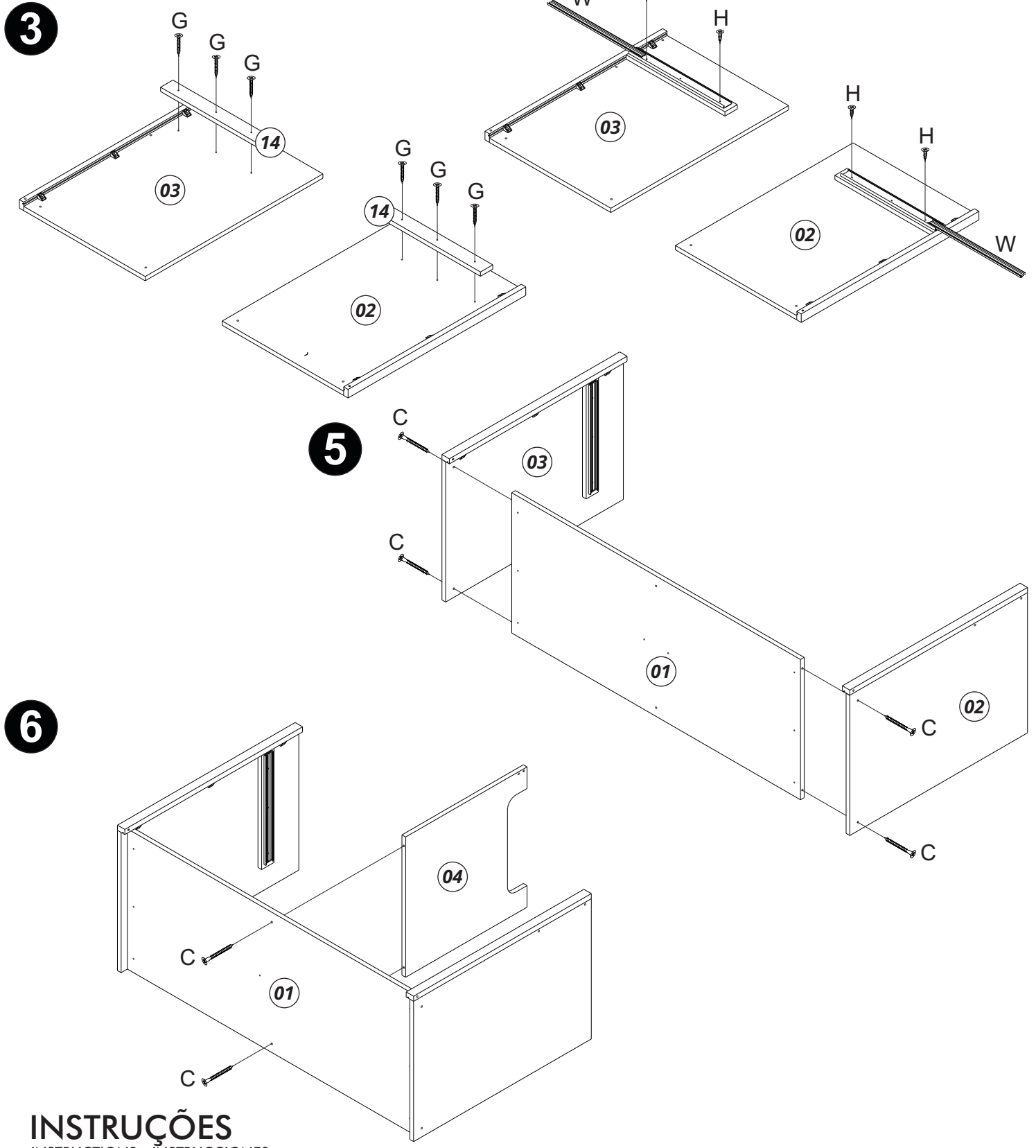

## INSTRUÇÕES

INSTRUCTIONS - INSTRUCCIONES

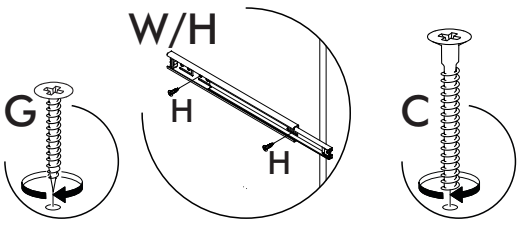

# MONTAGEM

ASSEMBLY - MONTAJE

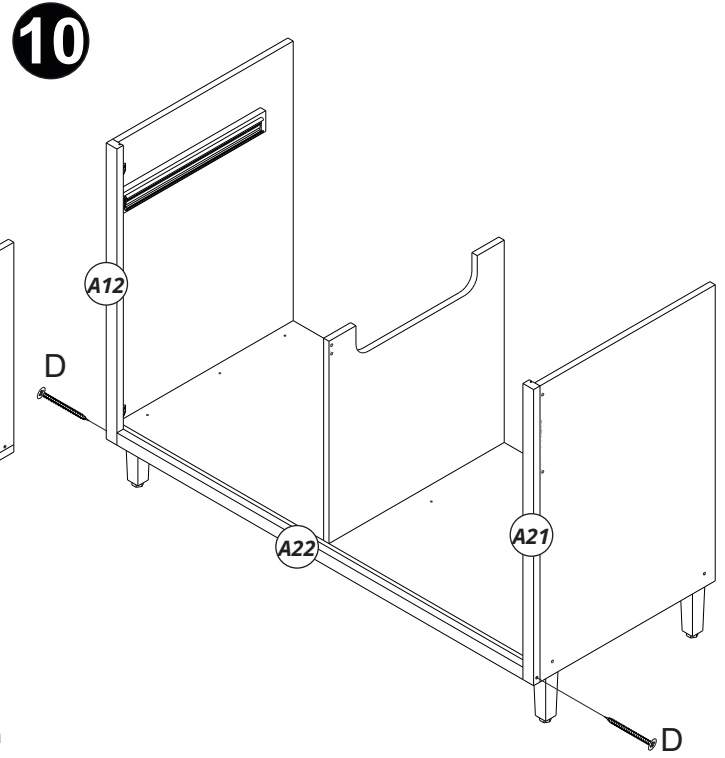
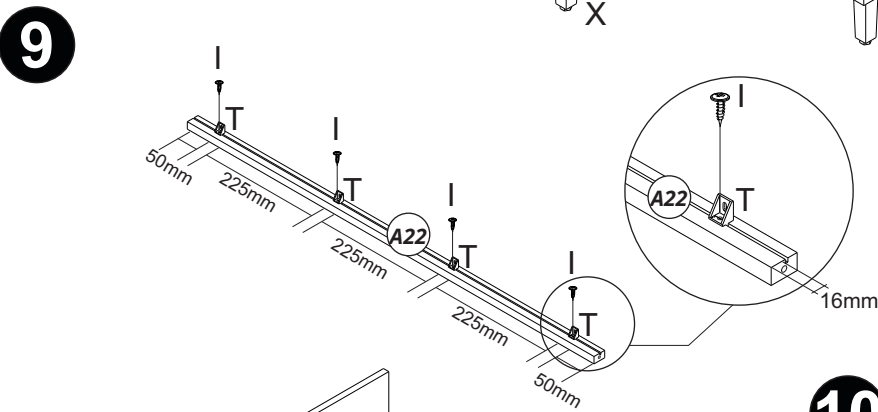
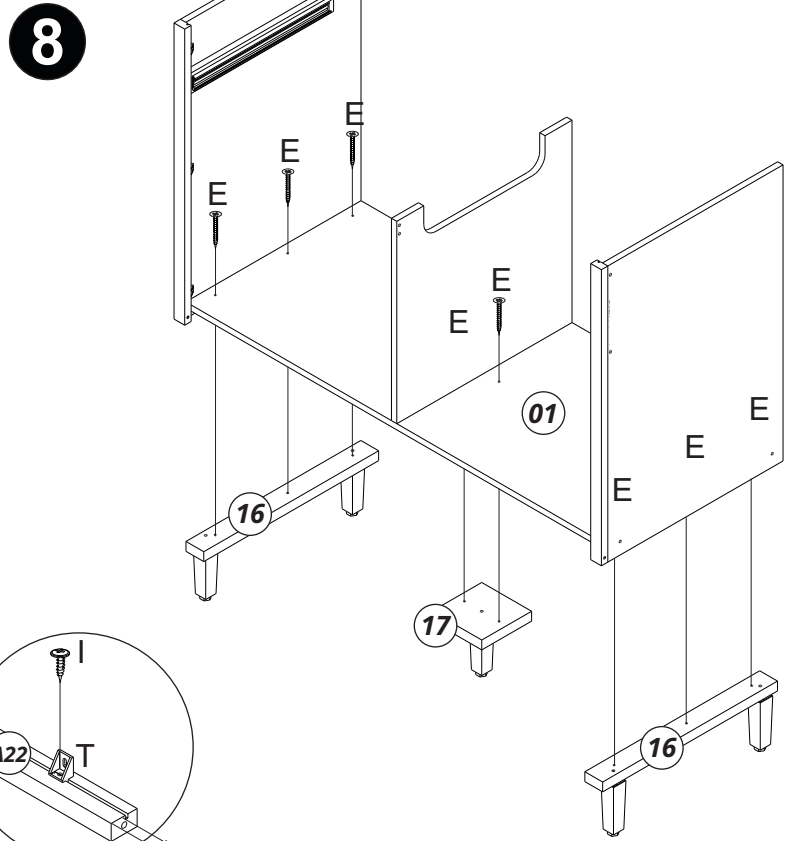
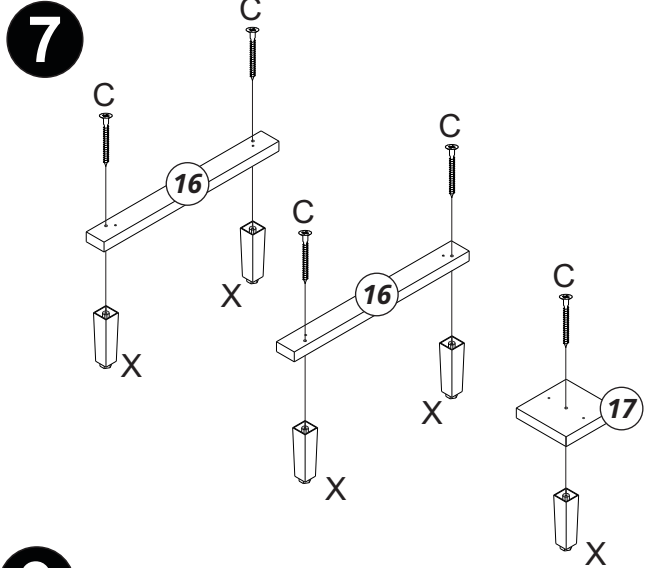

## INSTRUÇÕES

INSTRUCTIONS - INSTRUCCIONES

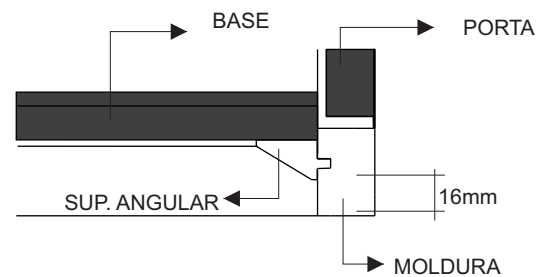
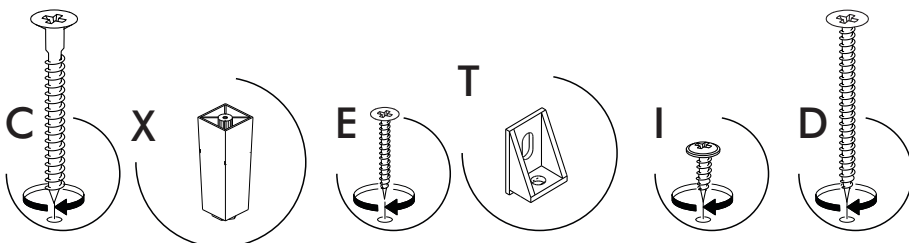

# MONTAGEM

ASSEMBLY - MONTAJE

11

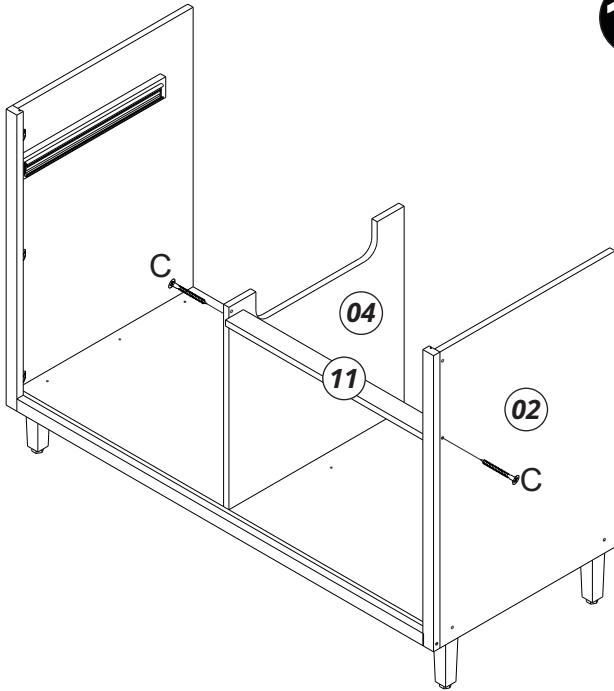

12

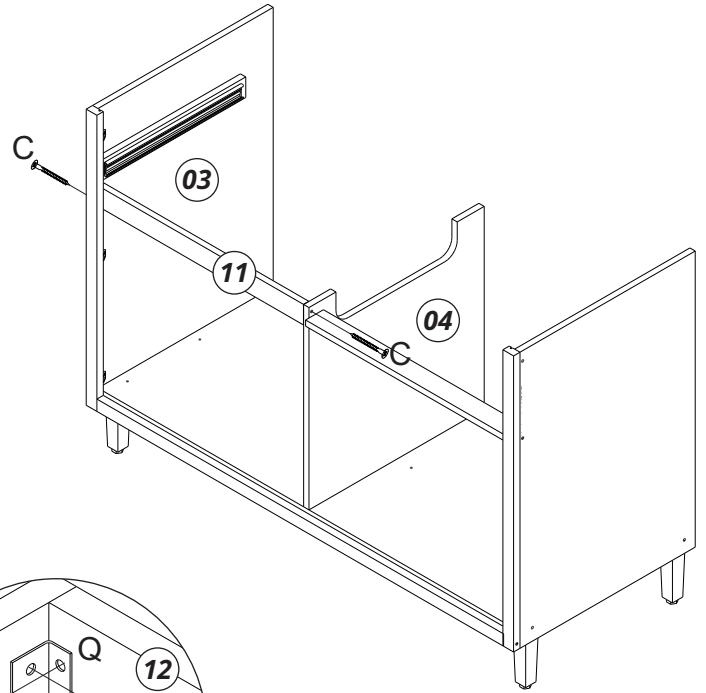

13

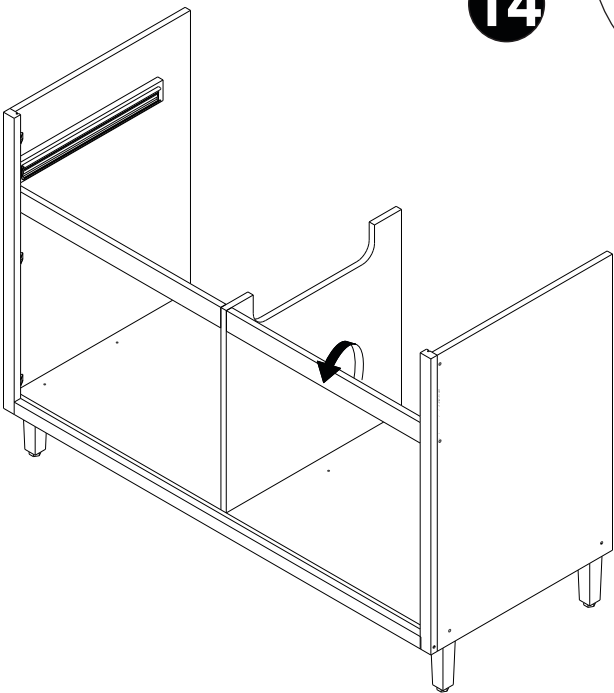

14

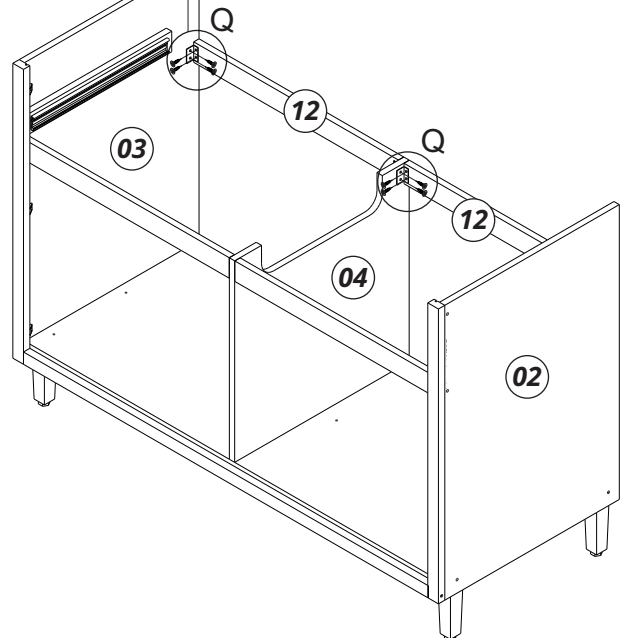
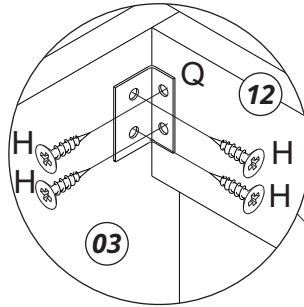

## INSTRUÇÕES

INSTRUCTIONS - INSTRUCCIONES

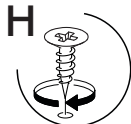
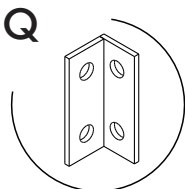
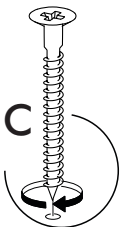

# MONTAGEM

ASSEMBLY - MONTAJE

15

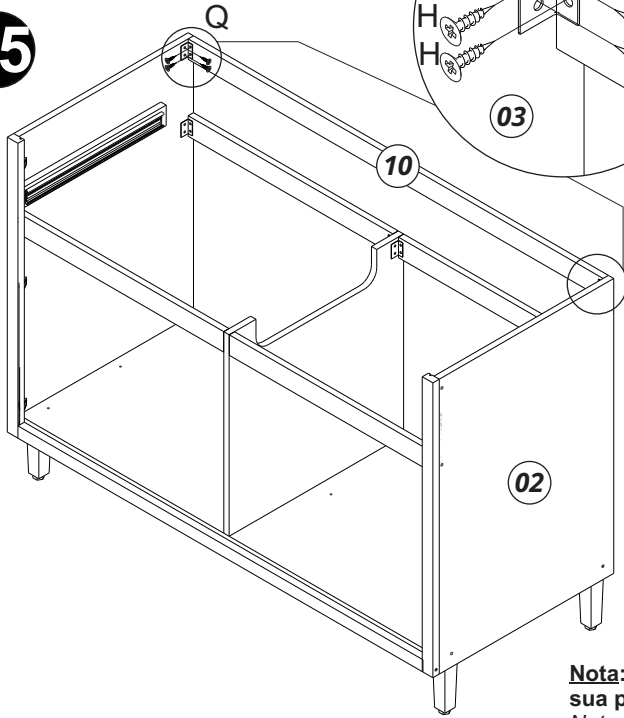

16

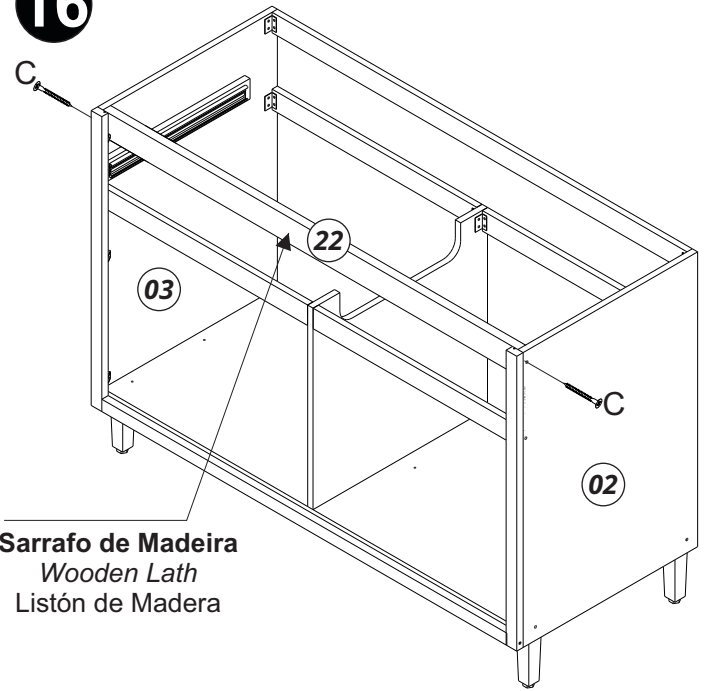

Sarrafo de Madeira  
Wooden Lath  
Listón de Madera

**Nota:** A peça (22) deve ser montada conforme as especificações, uma vez que sua presença é essencial para garantir a integridade e segurança do produto.

*Note:* The piece (22) must be assembled according to specifications, as its presence is essential to ensure the integrity and safety of the product.

*Nota:* La pieza (22) debe ensamblarse según las especificaciones, ya que su presencia es esencial para garantizar la integridad y seguridad del producto.

17

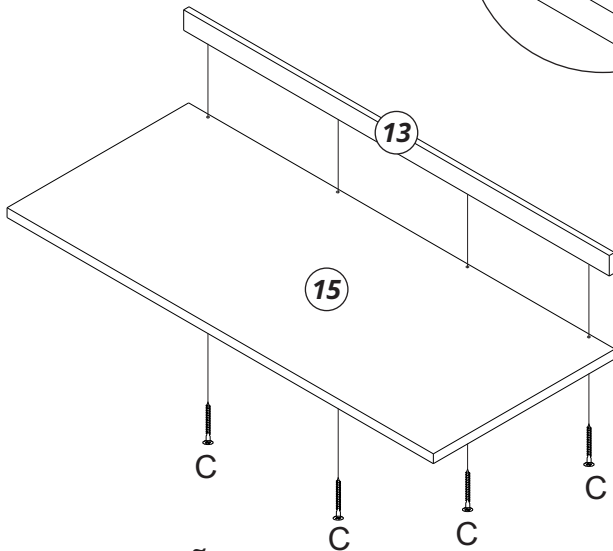

18

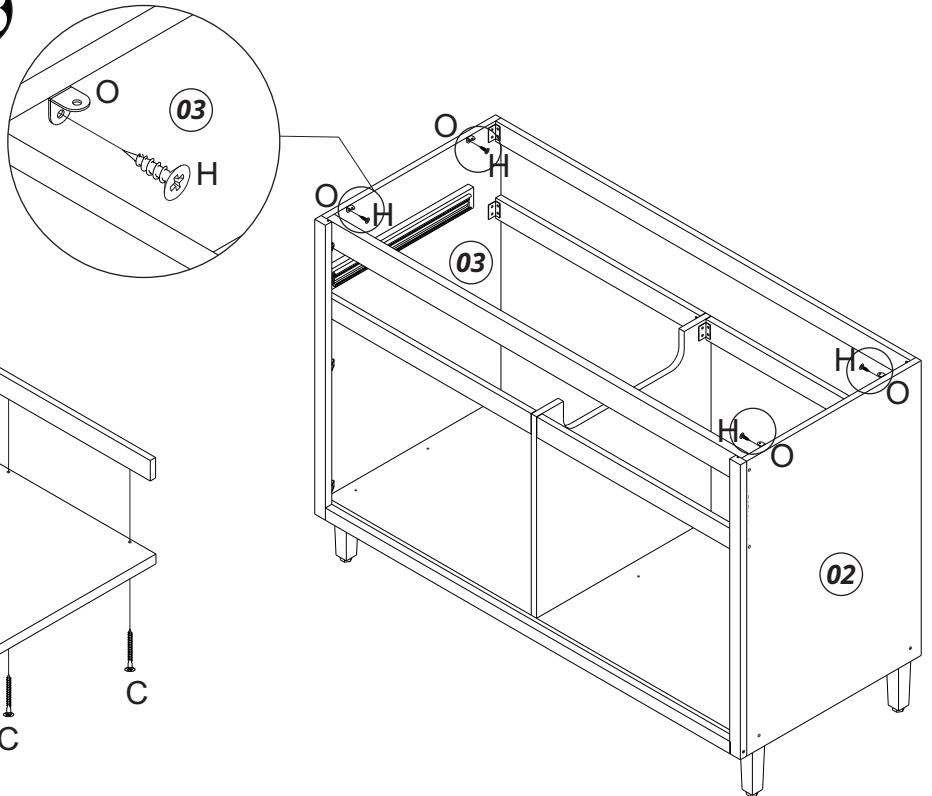

# INSTRUÇÕES

INSTRUCTIONS - INSTRUCCIONES

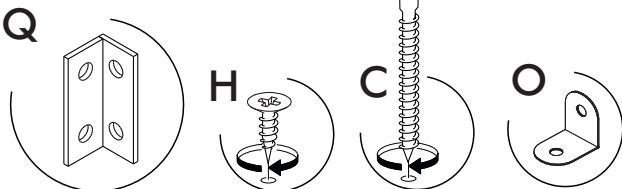

# MONTAGEM

ASSEMBLY - MONTAJE

19

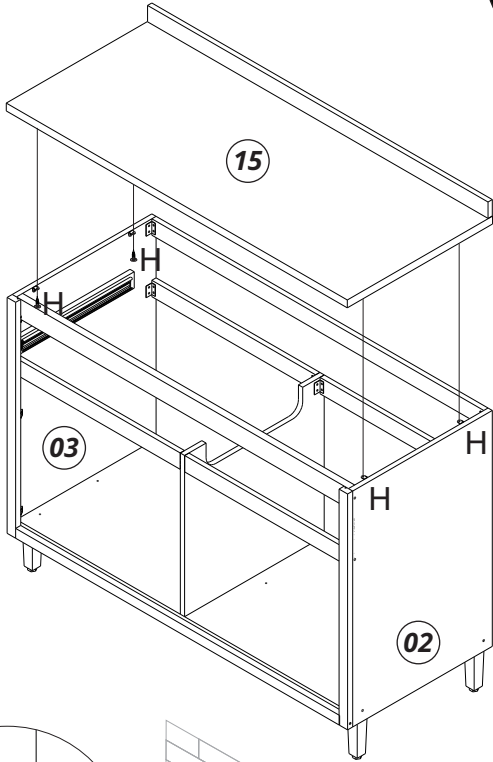

20

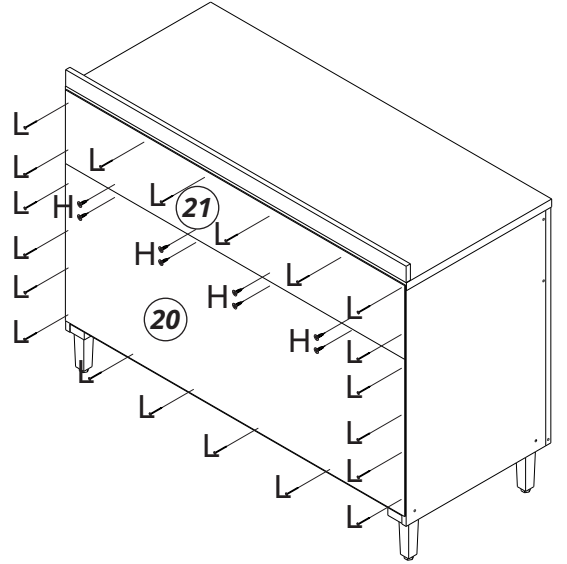

21

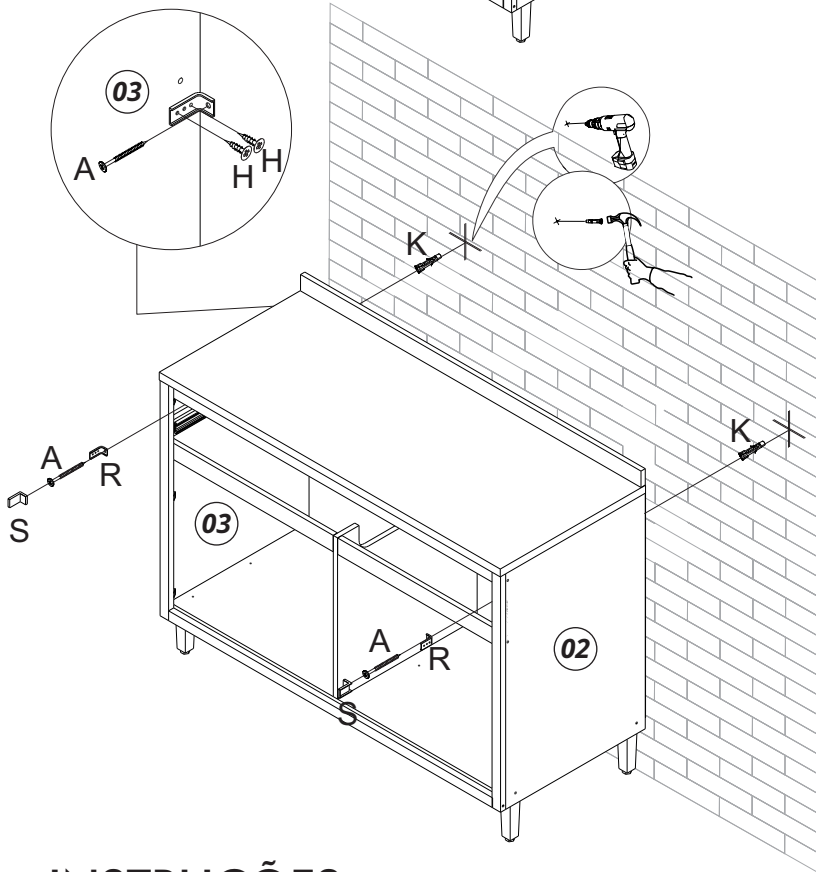

22

Montagem da gaveta "Tampo"  
 Assembly of the Drawer "Top"  
 Montaje del Cajón "Tapa"

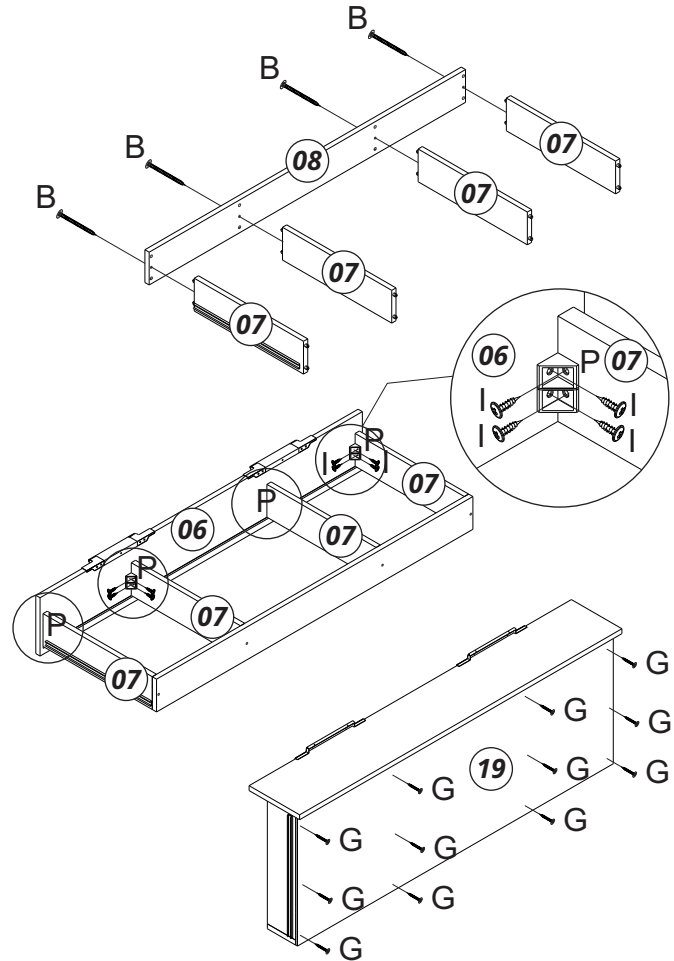

## INSTRUÇÕES

INSTRUCTIONS - INSTRUCCIONES

L

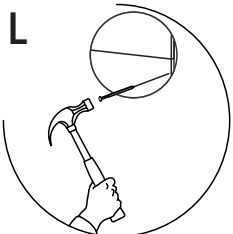

R

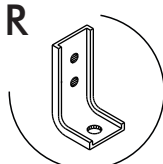

K



A

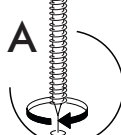

S

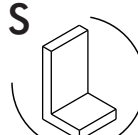

B

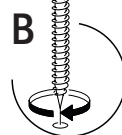

H



P

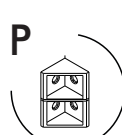

G

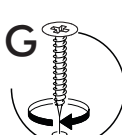

# MONTAGEM

ASSEMBLY - MONTAJE

## 23 Montagem da gaveta "Pia" Assembly of the Drawer "Sink" Montaje del Cajón "Fregadero"

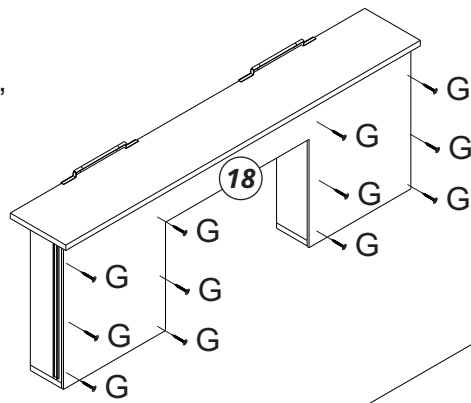
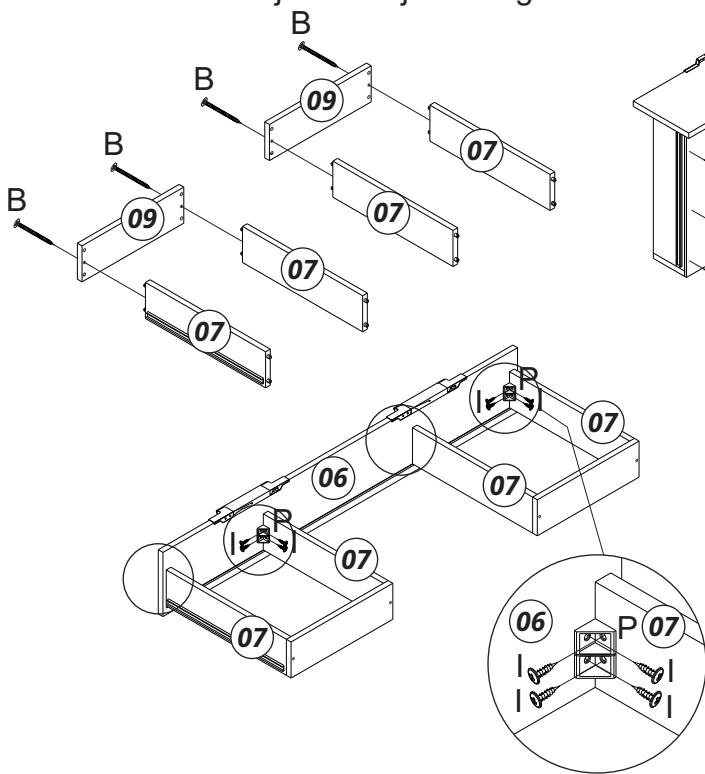

24

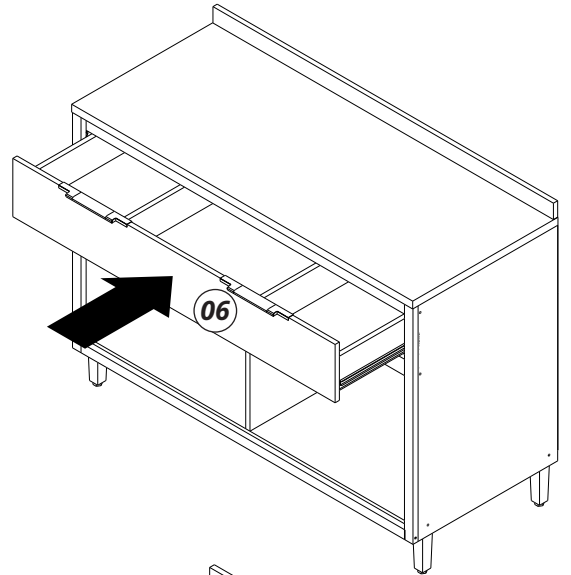

25

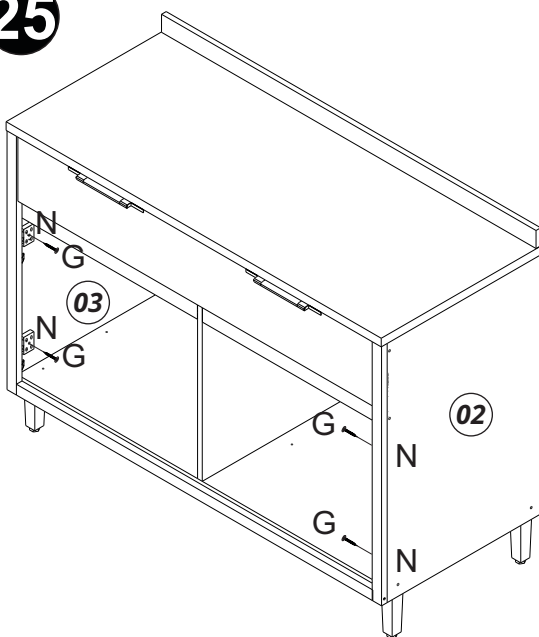

26

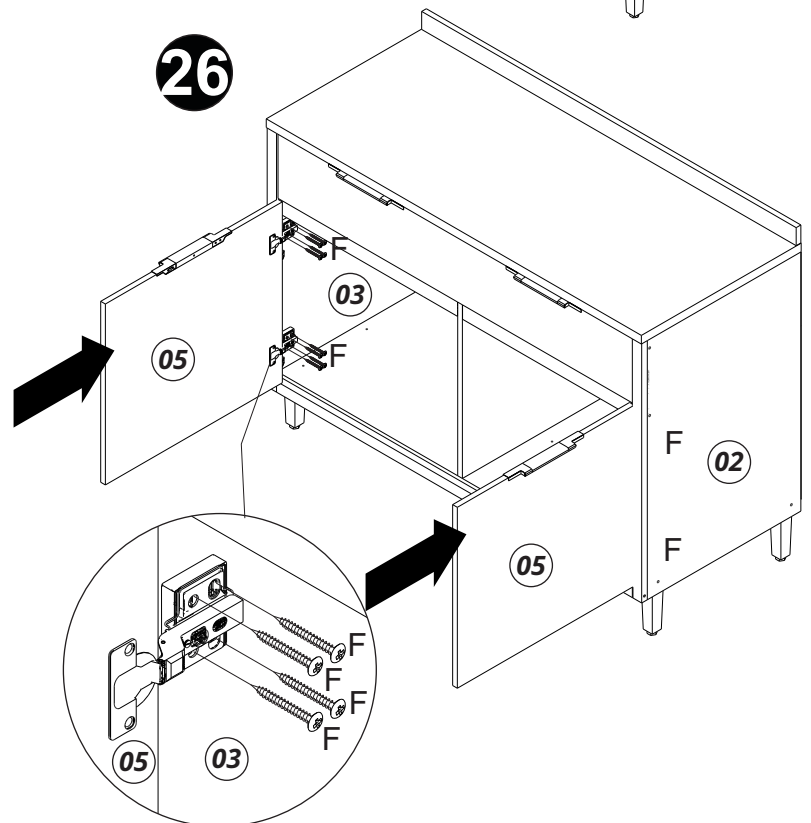

## INSTRUÇÕES

INSTRUCTIONS - INSTRUCCIONES

