

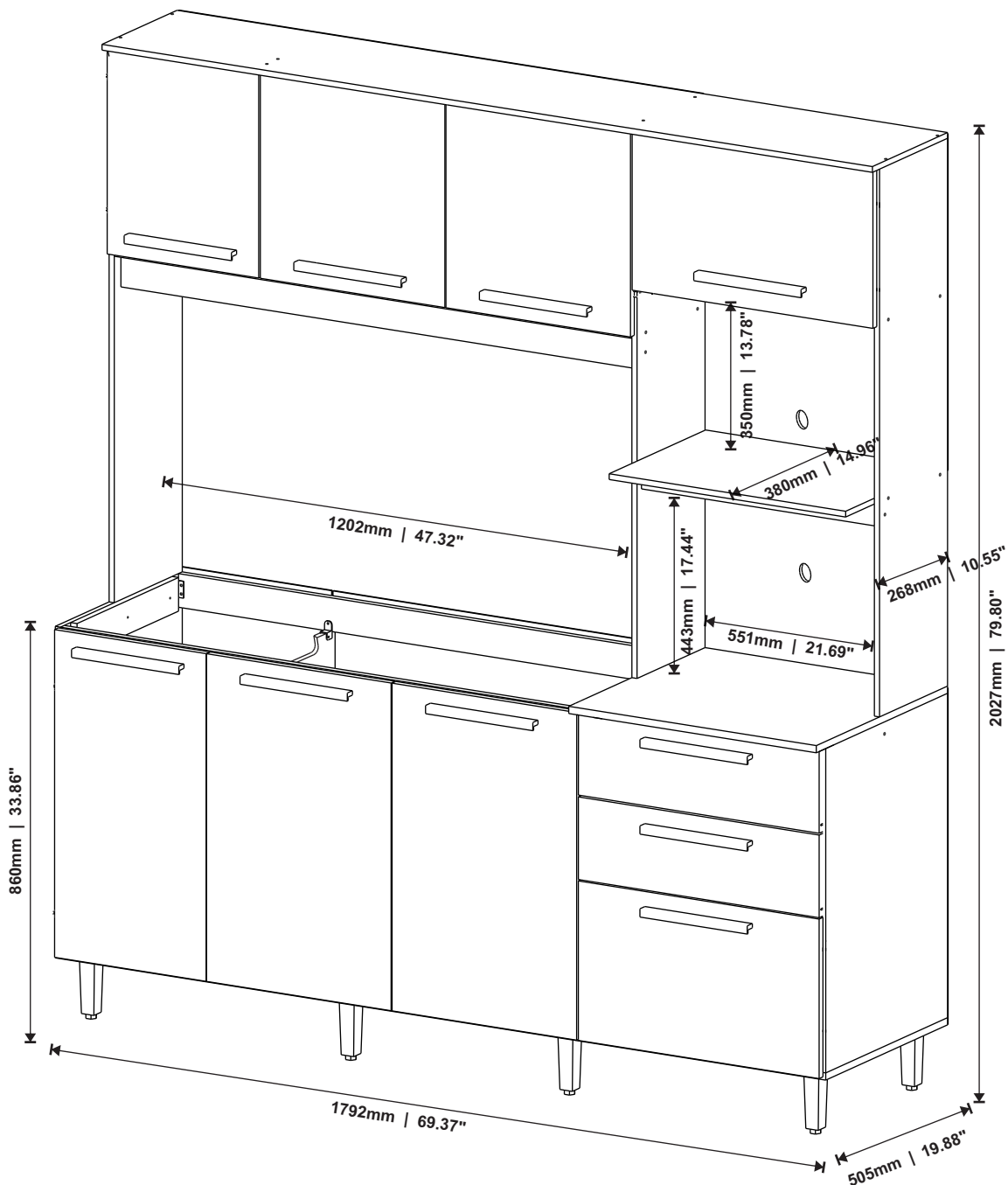

VITAMOV

COZINHA APOLLO KITCHEN CABINET APOLLO ARMARIO DE COCINNA APOLLO



Rua Augusto Zanforlim, 1-25 - Distrito Industrial
CEP: 15520-000, Valentim Gentil/SP - Cx. Postal 18
Fone: (17) 3485-1336
vitamov@vitamov.com.br

ACESSÓRIOS

ACCESSORIES - ACCESORIOS

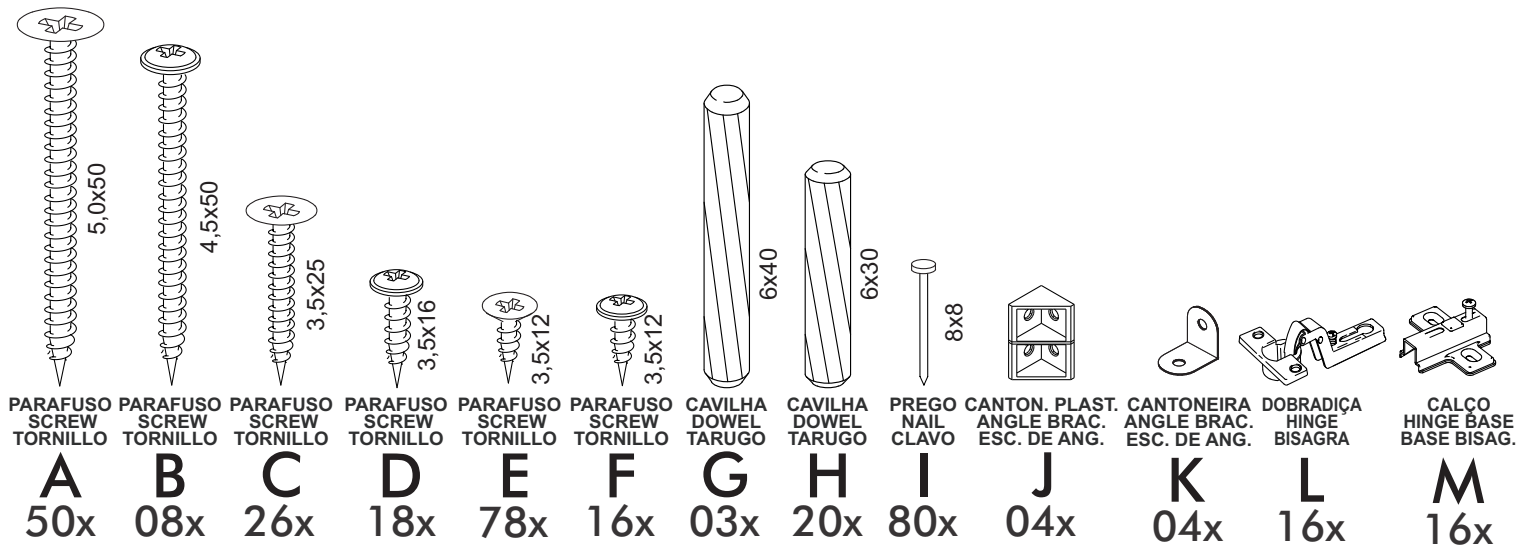

CÓD. ASSIST. 2510 CÓD. ASSIST. 5080 CÓD. ASSIST. 4829

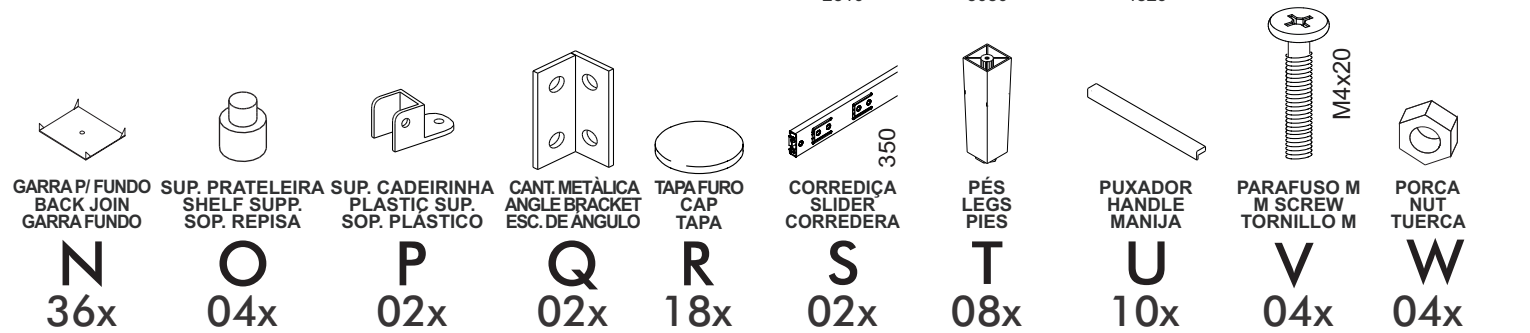

CAPACIDADE DE CARGA

LOAD CAPACITY - CAPACIDAD DE CARGA

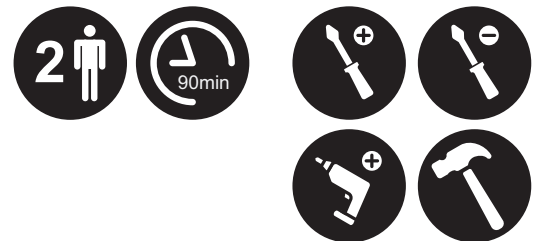
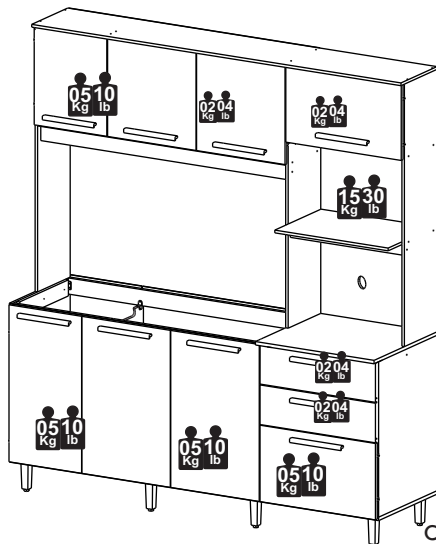

AS FERRAMENTAS NECESSÁRIAS PARA A MONTAGEM DO PRODUTO NÃO SÃO FORNECIDAS PELA EMPRESA. THE TOOLS NEEDED FOR THE PRODUCT ASSEMBLY ARE NOT PROVIDED BY THE COMPANY. LAS HERRAMIENTAS NECESARIAS PARA LA EL MONTAJE DEL PRODUCTO NO SON PROPORCIONADO POR LA EMPRESA.

A CAPACIDADE DE CARGA INDICADA É DISTRIBUIDA NAS ÁREAS DEMONSTRADAS.

THE INDICATED LOAD CAPACITY IS DISTRIBUTED IN THE SHOWN AREAS.

LA CAPACIDAD DE CARGA INDICADA ES DISTRIBUIDA EN ZONAS DEMONSTRADAS.

CERTIFICADO DE GARANTIA

CERTIFICATE OF WARRANTY - CERTIFICADO DE GARANTÍA

DISPOSIÇÕES

O projeto, instalação e a montagem na residência do consumidor não é responsabilidade da Vitamov. A montagem deve seguir corretamente as instruções que se encontram dentro da embalagem de cada módulo.

A Vitamov se reserva o direito de efetuar modificações de caráter técnico em seus produtos, sem aviso prévio.

EXCLUSÃO DA GARANTIA

O presente termo exclui de sua garantia:

- danos causados em consequência de acidentes, mau uso, manuseio ou deslocamento incorreto dos produtos;
- danos causados por montagem inadequada;
- danos em decorrência de agentes externos (inundações, incêndio, etc);
- defeitos oriundos de umidade excessiva

A fixação dos armários de forma segura e garantida depende da qualidade da parede na qual os mesmos serão instalados.

A Vitamov não se responsabiliza por danos causados por instalações dos armários em paredes inadequadas.

PROVISIONS

The design, installation and assembly in the consumer's home is not the responsibility of Vitamov. Assembly must correctly follow the instructions given found inside the packaging of each module. Vitamov reserves the right to make technical changes to its products without prior notice.

EXCLUSION OF WARRANTY

This term excludes from its warranty:

- damage caused as a result of accidents, misuse, incorrect handling or displacement of the products;
- damage caused by improper assembly;
- damage resulting from external agents (floods, fire, etc.);
- defects from excessive humidity. Fixing the cabinets safely and securely depends on the quality of the wall on which they will be installed. Vitamov is not responsible for damage caused by installing cabinets on inadequate walls.

PROVISIONES

El diseño, instalación y montaje en el domicilio del consumidor no es responsabilidad de Vitamov. El montaje debe seguir correctamente las instrucciones dadas que se encuentra dentro del embalaje de cada módulo. Vitamov se reserva el derecho de realizar cambios técnicos en sus productos sin previo aviso.

EXCLUSIÓN DE GARANTÍA

Este certificado excluye de su garantía:

- daños causados como consecuencia de accidentes, mal uso, manejo incorrecto o desplazamiento de los productos;
- daños causados por un montaje inadecuado;
- daños resultantes de agentes externos (inundaciones, incendios, etc.);
- defectos por exceso de humedad. La fijación de los gabinetes de manera segura y segura depende de la calidad de la pared en la que se instalarán.

Vitamov no es responsable de daños causados por instalar gabinetes en paredes inadecuadas.

PEÇAS

PIECES - PIEZAS

Nº PÇ	PORTUGUÊS	ENGLISH	ESPAÑOL	Medidas/Measures/ Medidas	Qtde.	Cod. Assist.
1	Base	Base	Panel Base	1794 x 480 x 15	1	4870
2	Divisória Inferior Direita	Bottom Right Divider	Divisor Inferior Derecho	675 x 480 x 12	1	4875
3	Divisória Inferior Esquerda	Bottom Left Divider	Divisor Inferior Izquierdo	605 x 480 x 12	1	4874
4	Lateral Inferior Esquerda	Bottom Left Side Panel	Panel Lateral Inferior Izquierdo	675 x 480 x 12	1	4872
5	Lateral Inferior Direita	Bottom Right Side Panel	Panel Lateral Inferior Derecho	675 x 480 x 12	1	4871
6	Prateleira Móvel	Adjustable Shelf	Estante Ajustable	340 x 306 x 12	1	4873
7	Frente de Gaveta	Drawer Front	Frente de Cajón	561 x 172 x 15	2	4895
8	Lateral de Gaveta	Drawer Side	Lateral de Cajón	350 x 100 x 12	4	4896
9	Contra Fundo de Gaveta	Drawer Back Panel	Panel Trasero de Cajón	527 x 100 x 12	2	4879
10	Tampo da Torre	Tower Top Panel	Panel Superior de la Torre	577 x 505 x 15	1	4897
11	Lateral Superior Direita	Upper Right Side Panel	Panel Lateral Superior Derecho	1140 x 268 x 12	1	4882
12	Lateral Superior Esquerda	Upper Left Side Panel	Panel Lateral Superior Izquierdo	1155 x 268 x 12	1	4889
13	Divisória Superior Direita	Upper Right Divider	Divisor Superior Derecho	1140 x 268 x 12	1	4892
14	Pontaletes	Support Post	Poste de Soporte	422 x 70 x 12	1	4877
15	Prateleira Inferior Aéreo	Upper Cabinet Bottom Shelf	Estante Inferior Aéreo	1202 x 268 x 12	1	4884
16	Prateleira Superior da Torre	Tower Upper Shelf	Estante Superior de la Torre	551 x 268 x 12	1	4883
17	Prateleira Microondas	Microwave Shelf	Estante para Microondas	551 x 380 x 12	1	4900
18	Travessa Prateleira Inferior Aéreo	Upper Cabinet Bottom Shelf Rail	Travesaño del Estante Inferior Aéreo	1202 x 70 x 15	1	4894
19	Tampo Superior	Top Panel	Panel Superior	1794 x 296 x 12	1	4878
20	Porta Superior Esquerda Menor	Upper Left Small Door	Puerta Superior Izquierda Pequeña	431 x 352 x 15	1	4886
21	Porta Superior Esquerda Maior	Upper Left Large Door	Puerta Superior Izquierda Grande	431 x 431 x 15	1	4885
22	Porta Superior Direita Maior	Upper Right Large Door	Puerta Superior Derecha Grande	431 x 431 x 15	1	4885
23	Porta Torre Superior	Tower Upper Door	Puerta Superior de la Torre	563 x 334 x 15	1	4898
24	Porta Torre Inferior	Tower Lower Door	Puerta Inferior de la Torre	563 x 334 x 15	1	4899
25	Porta Inferior Maior Direita	Lower Right Large Door	Puerta Inferior Derecha Grande	684 x 431 x 15	1	4888
26	Porta Inferior Maior Esquerda	Lower Left Large Door	Puerta Inferior Izquierda Grande	684 x 431 x 15	1	4888
27	Porta Inferior Menor Esquerda	Lower Left Small Door	Puerta Inferior Izquierda Pequeña	684 x 352 x 15	1	4887
28	Prateleira Inferior Direita	Lower Right Shelf	Estante Inferior Derecho	850 x 306 x 12	1	4891
29	Travessa Menor da Pia	Sink Small Rail	Travesaño Pequeño del Fregadero	445 x 70 x 15	2	4876
30	Travessa Maior da Pia	Sink Large Rail	Travesaño Grande del Fregadero	1202 x 70 x 15	2	4893
31	Travessa do Forno	Oven Rail	Travesaño del Horno	551 x 50 x 12	1	4880
32	Travessa do Microondas	Microwave Rail	Travesaño del Microondas	551 x 50 x 12	1	4881
33	Fundo 1	Back Panel 1	Fondo 1	700 x 568 x 03	2	4890
34	Fundo 2	Back Panel 2	Fondo 2	568 x 455 x 03	1	4902
35	Fundo 3	Back Panel 3	Fondo 3	1218 x 445 x 03	1	4901
36	Fundo 4	Back Panel 4	Fondo 4	862 x 349 x 03	2	4905
37	Fundo 5	Back Panel 5	Fondo 5	700 x 357 x 03	1	4903
38	Fundo de Gaveta	Drawer Bottom Panel	Fondo de Cajón	525 x 366 x 03	2	4904

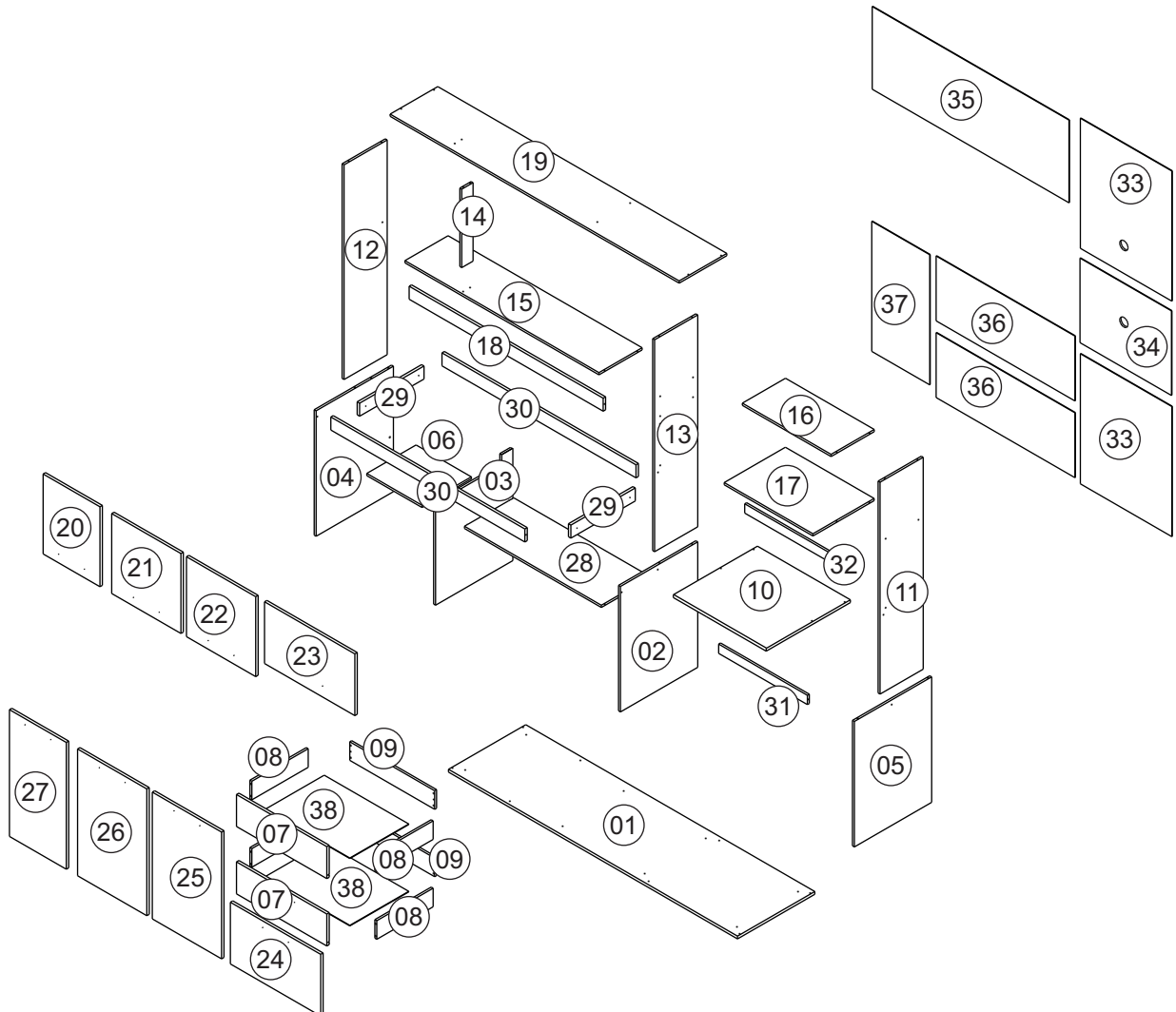

PRÉ-MONTAGEM

PRE ASSEMBLY - PRÉ-MONTAJE

IMPORTANTE ATTENTION - IMPORTANTE
A MONTAGEM DEVE SER REALIZADA POR UM PROFISSIONAL DE MONTAGEM.
ASSEMBLY MUST BE CARRIED OUT BY AN ASSEMBLY PROFESSIONAL.
EL MONTAJE DEBE SER HECHO POR UN MONTADOR DE MUEBLES.

1

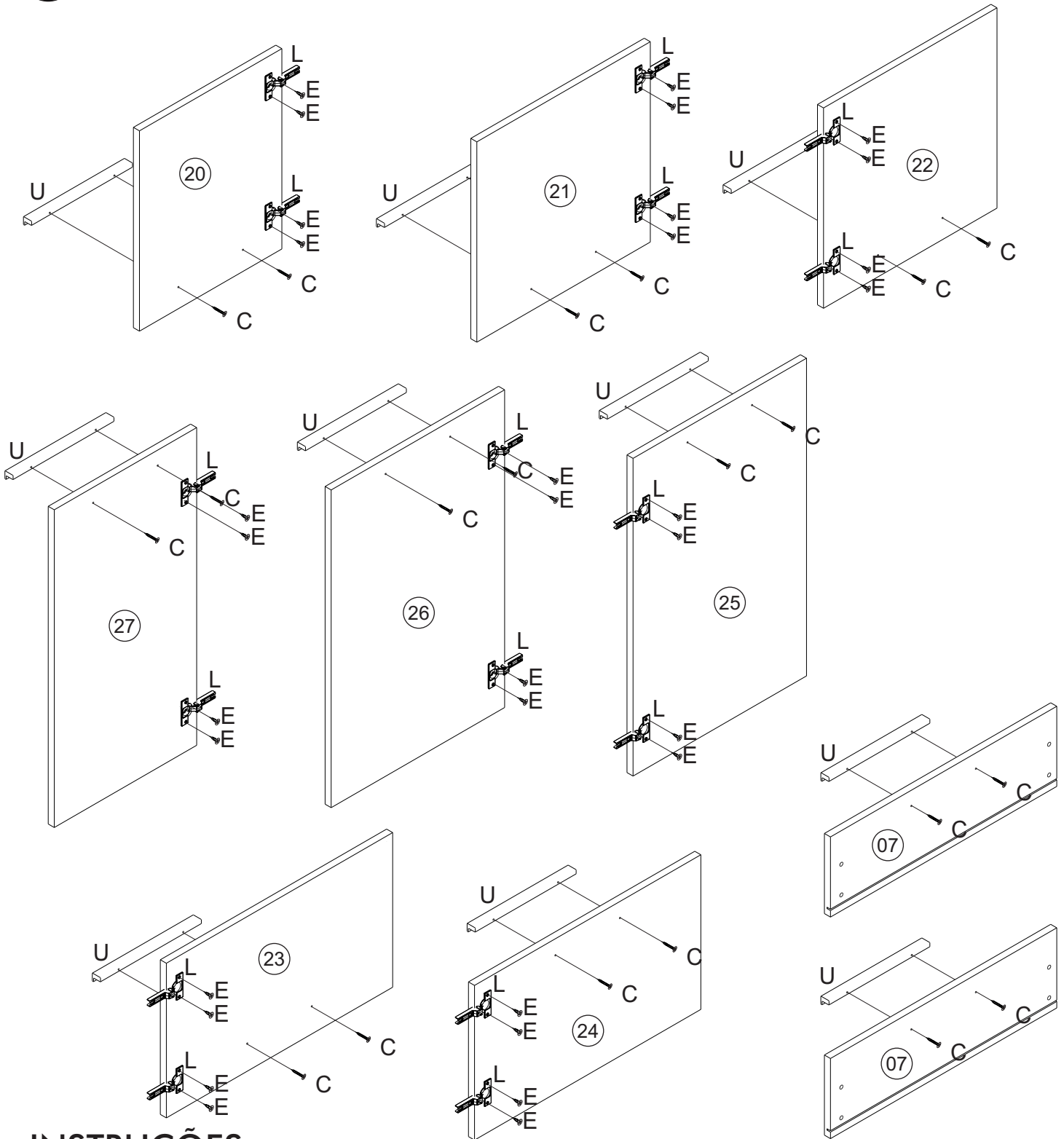

INSTRUÇÕES

INSTRUCTIONS - INSTRUCCIONES

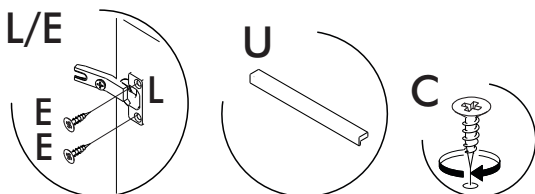

PRÉ-MONTAGEM

PRE ASSEMBLY - PRÉ-MONTAJE

IMPORTANT ATTENTION - IMPORTANTE
 A MONTAGEM DEVE SER REALIZADA POR UM PROFISSIONAL DE MONTAGEM.
 ASSEMBLY MUST BE CARRIED OUT BY AN ASSEMBLY PROFESSIONAL.
 EL MONTAJE DEBE SER HECHO POR UN MONTADOR DE MUEBLES.

2

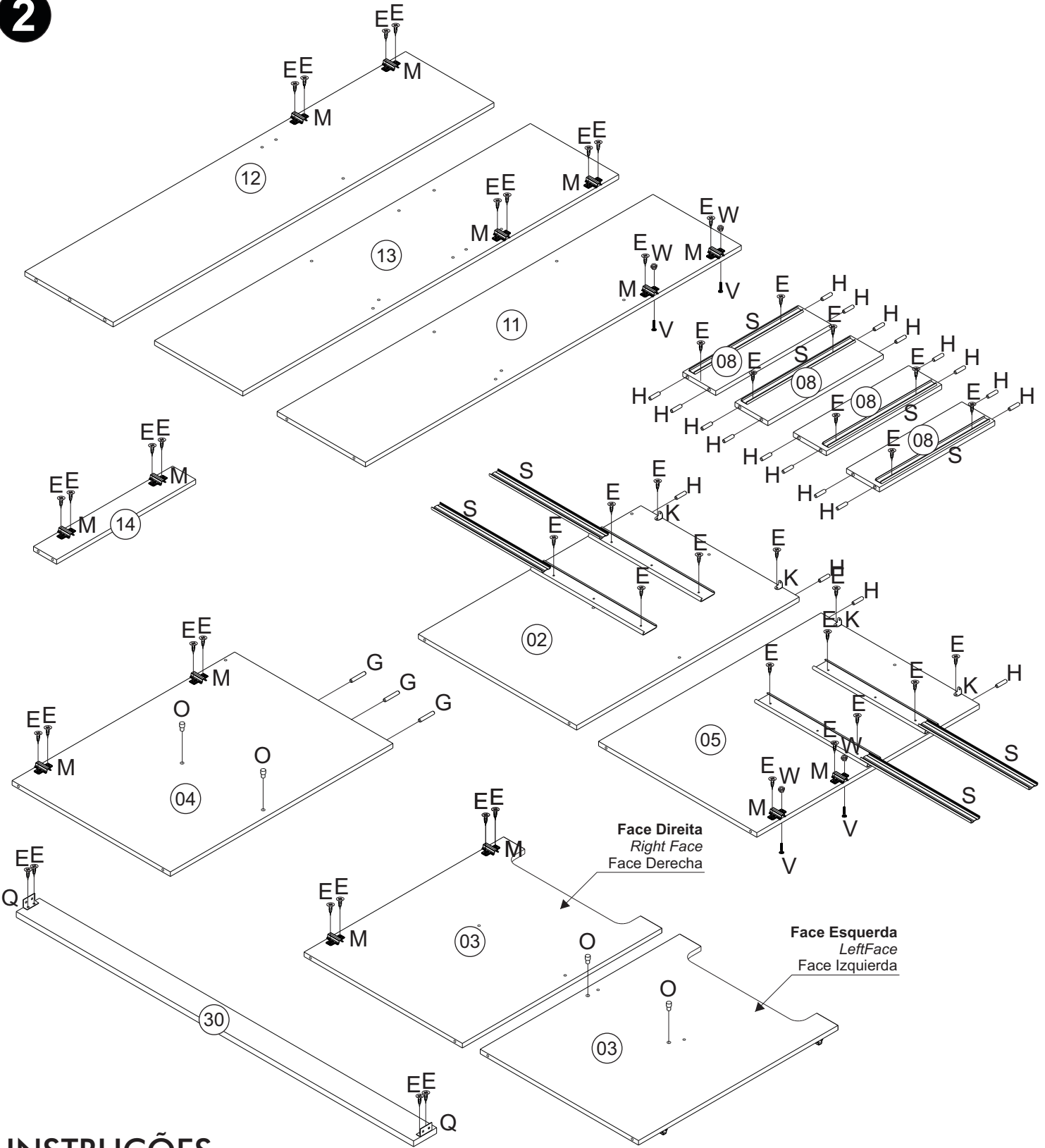

INSTRUÇÕES

INSTRUCTIONS - INSTRUCCIONES

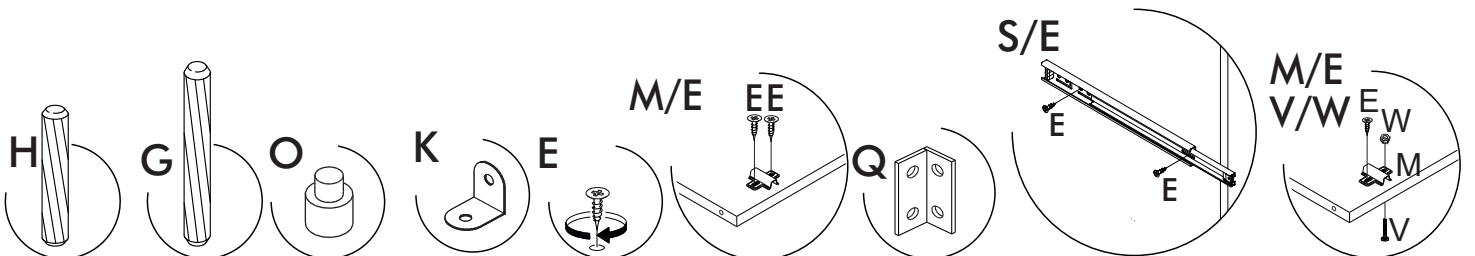

MONTAGEM

ASSEMBLY - MONTAJE

1

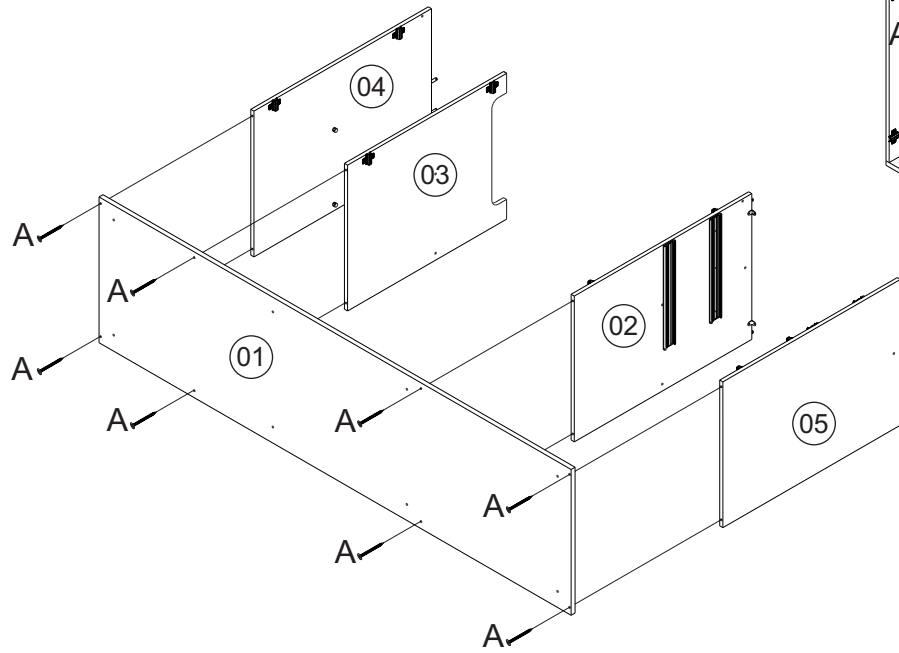

2

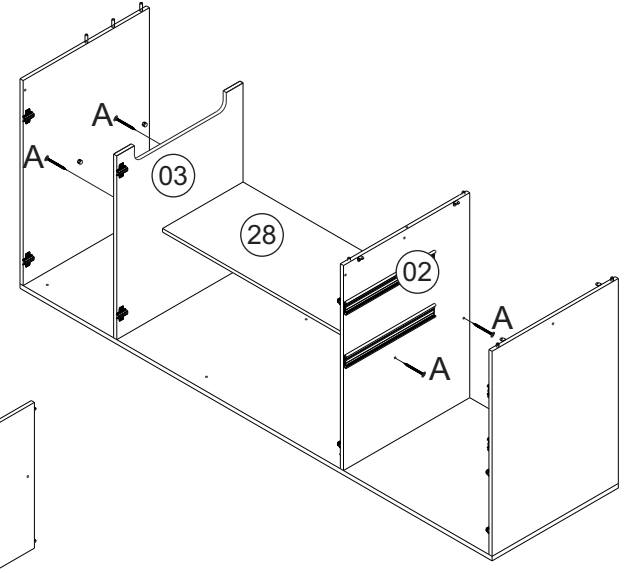

3

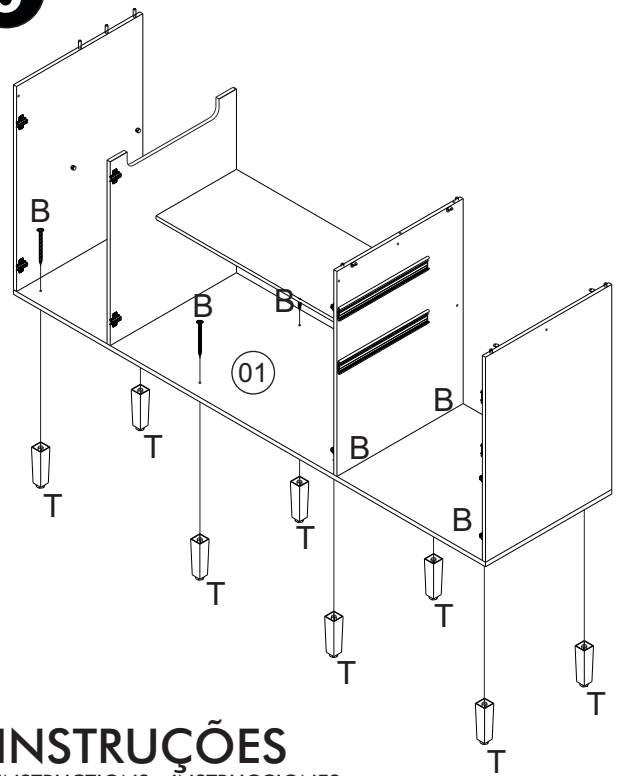

4

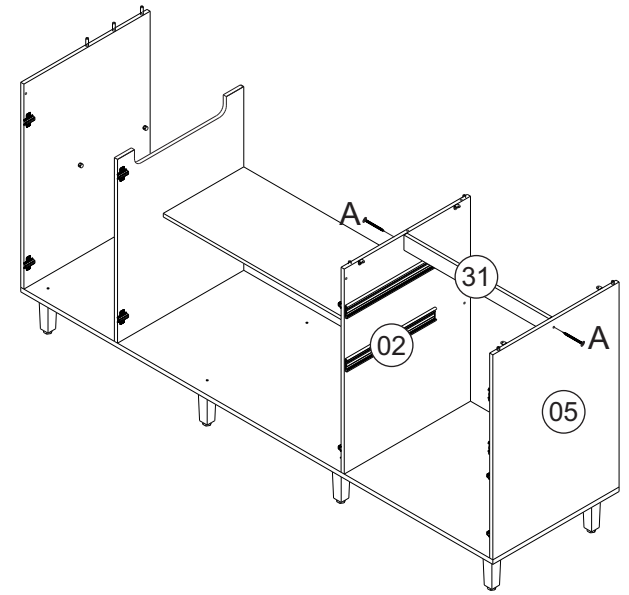

INSTRUÇÕES

INSTRUCTIONS - INSTRUCCIONES

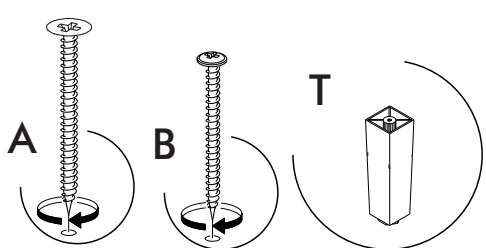

MONTAGEM

ASSEMBLY - MONTAJE

5

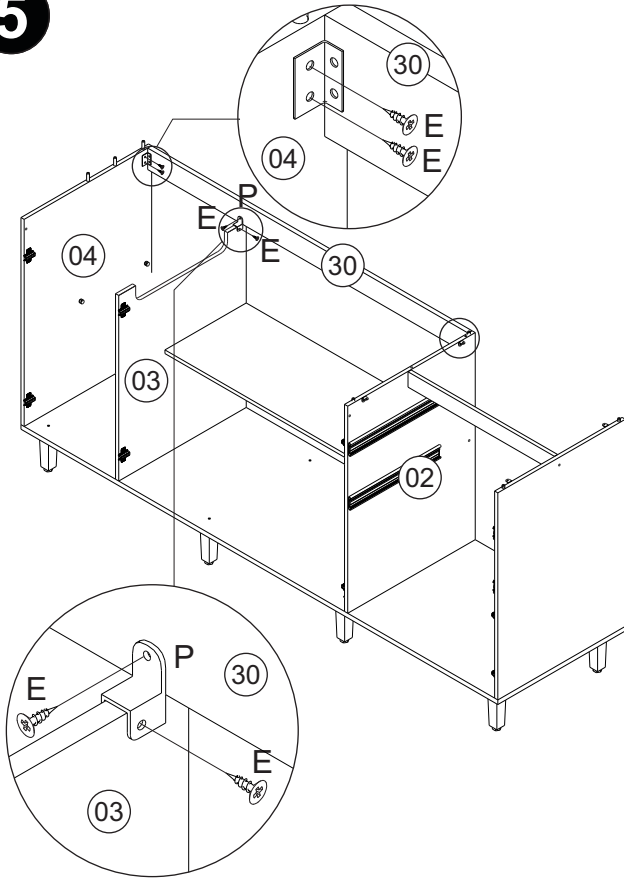

6

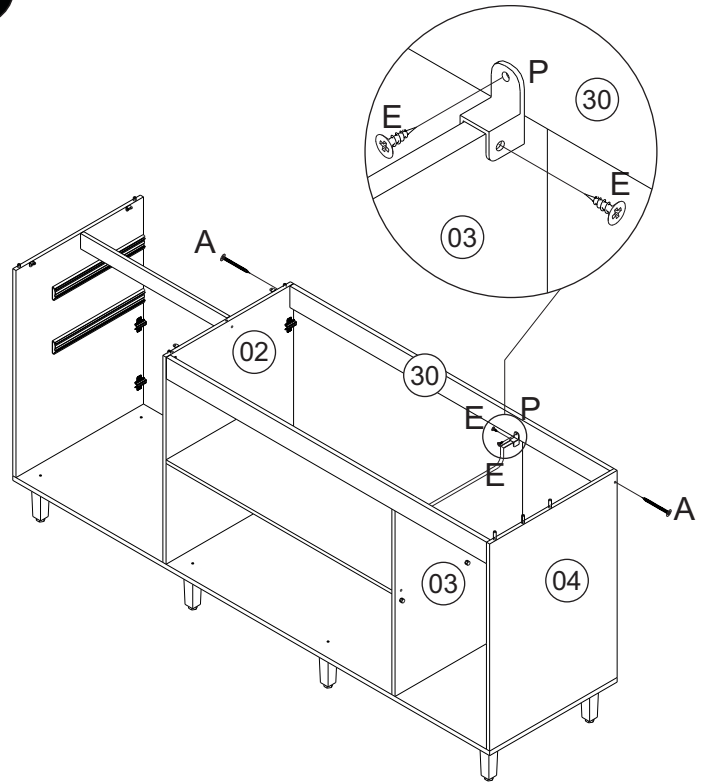

7

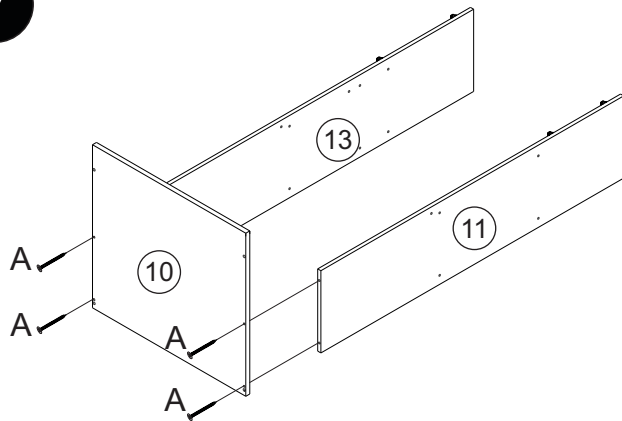

8

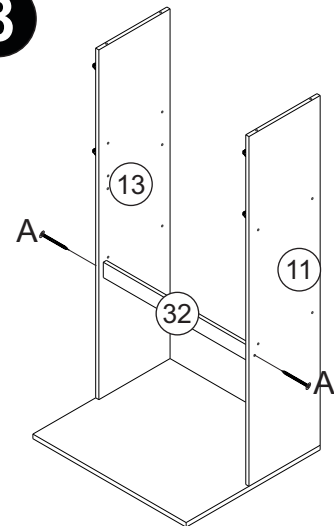

INSTRUÇÕES

INSTRUCTIONS - INSTRUCCIONES

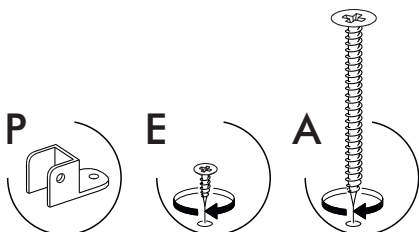

MONTAGEM

ASSEMBLY - MONTAJE

9

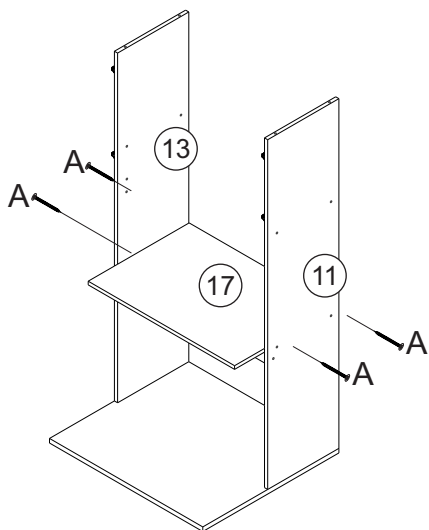

10

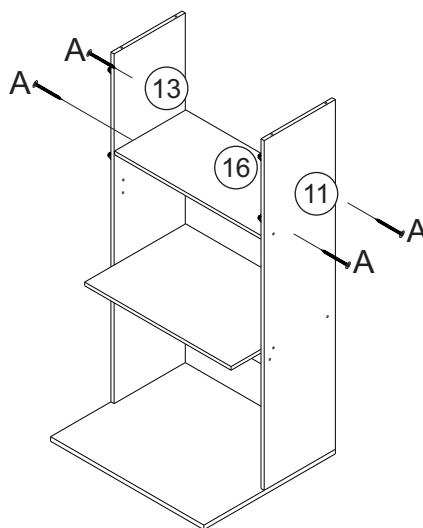

11

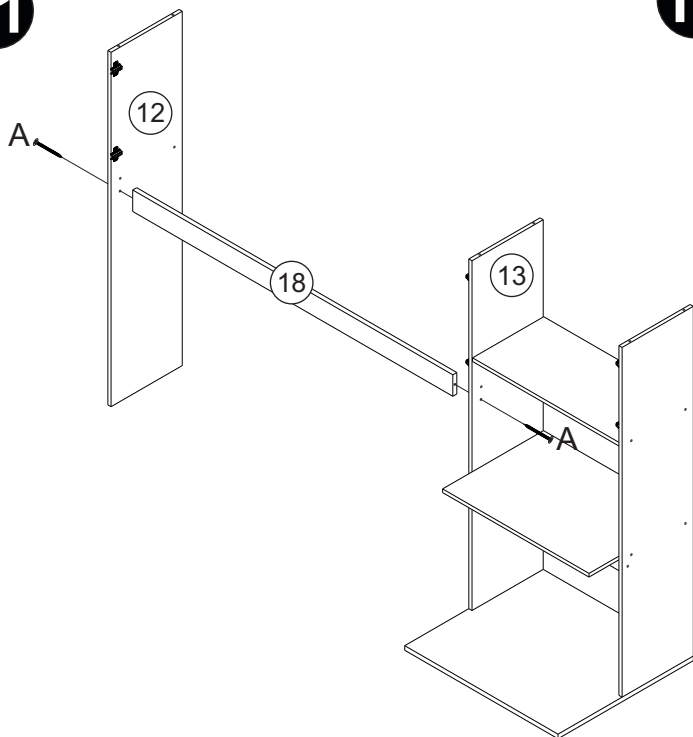

12

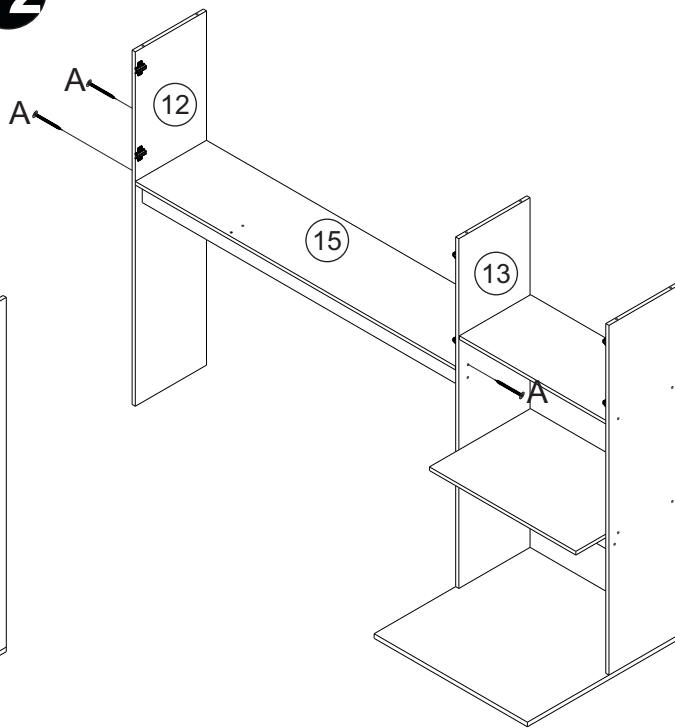

INSTRUÇÕES

INSTRUCTIONS - INSTRUCCIONES

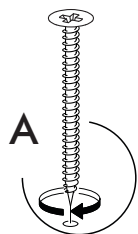

MONTAGEM

ASSEMBLY - MONTAJE

13

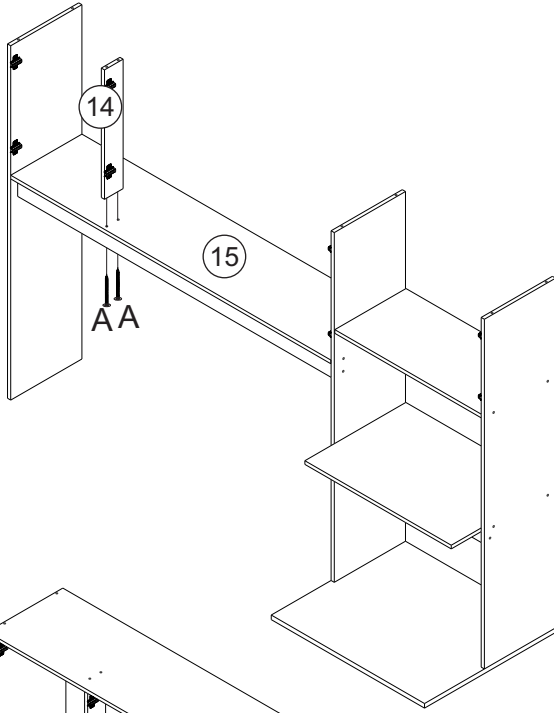

14

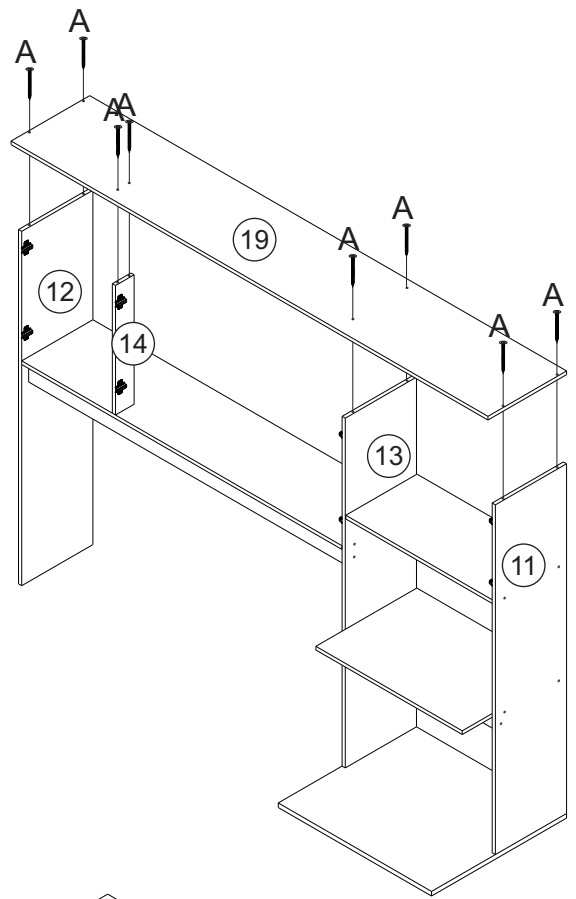

15

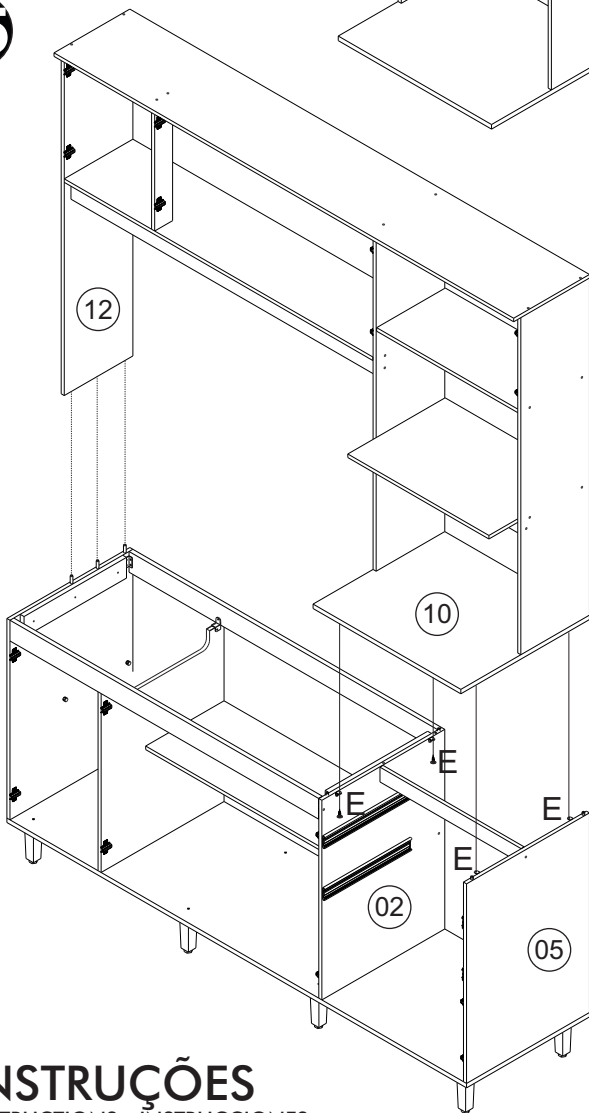

16

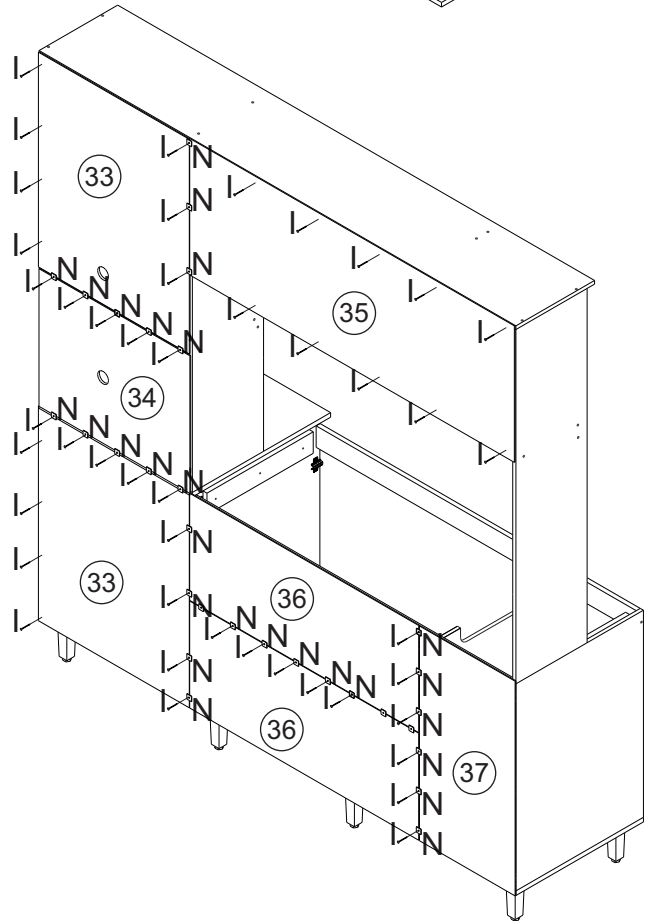

INSTRUÇÕES

INSTRUCTIONS - INSTRUCCIONES

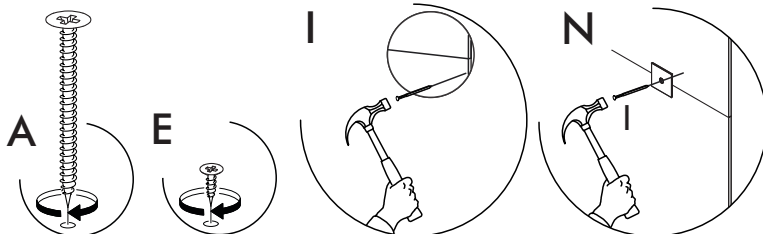

MONTAGEM

ASSEMBLY - MONTAJE

18 2x

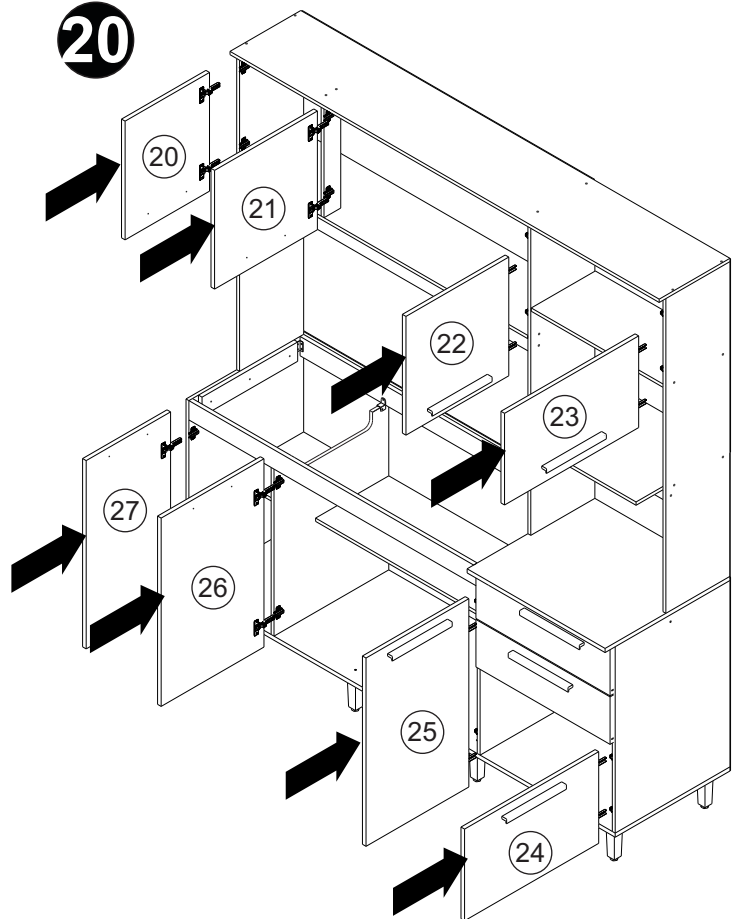
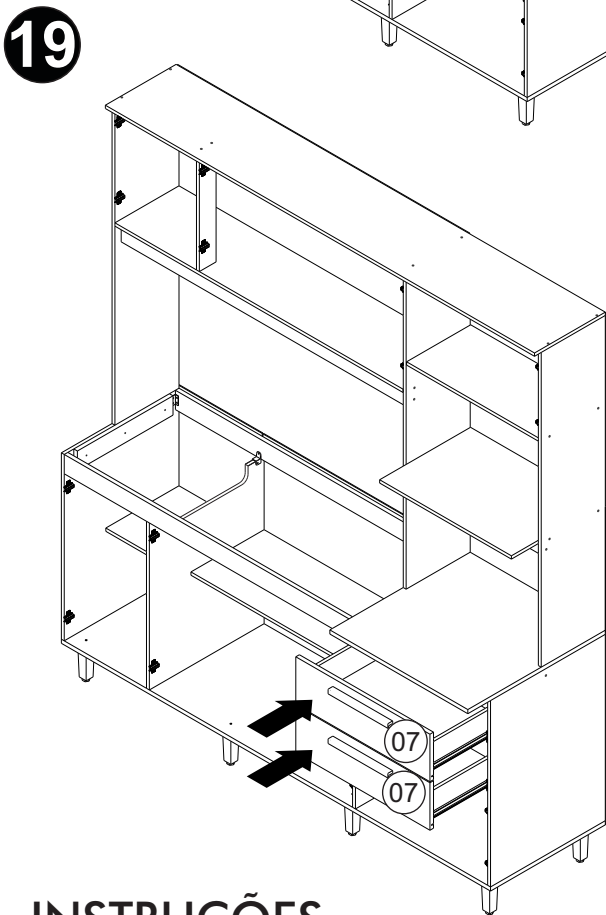
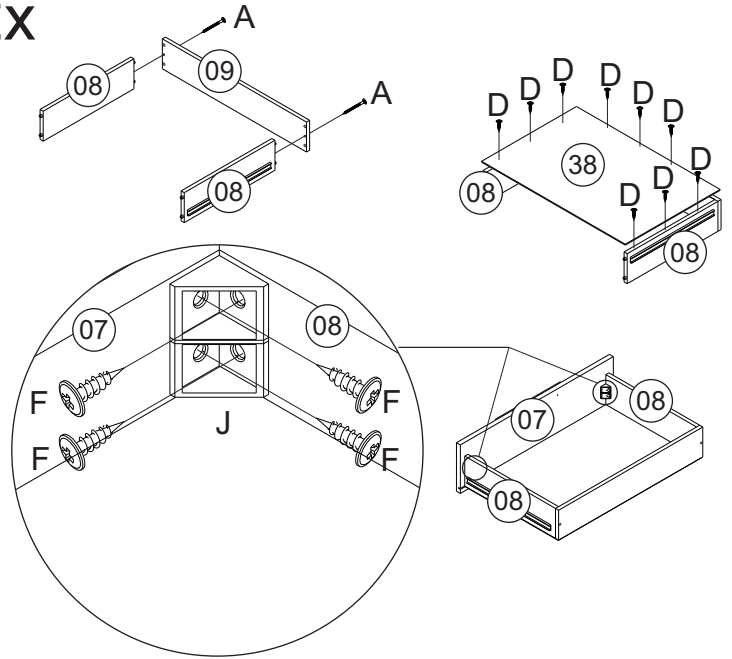
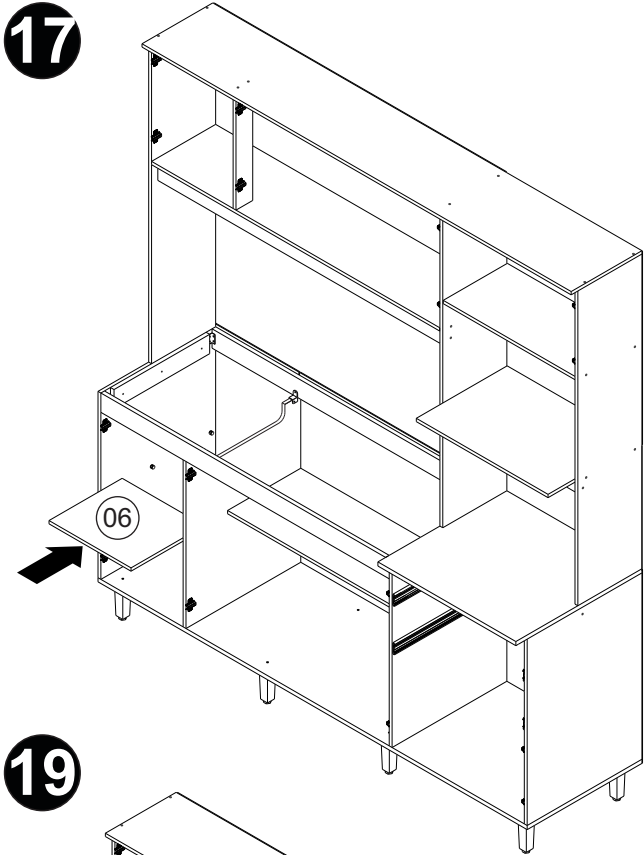

INSTRUÇÕES

INSTRUCTIONS - INSTRUCCIONES

