

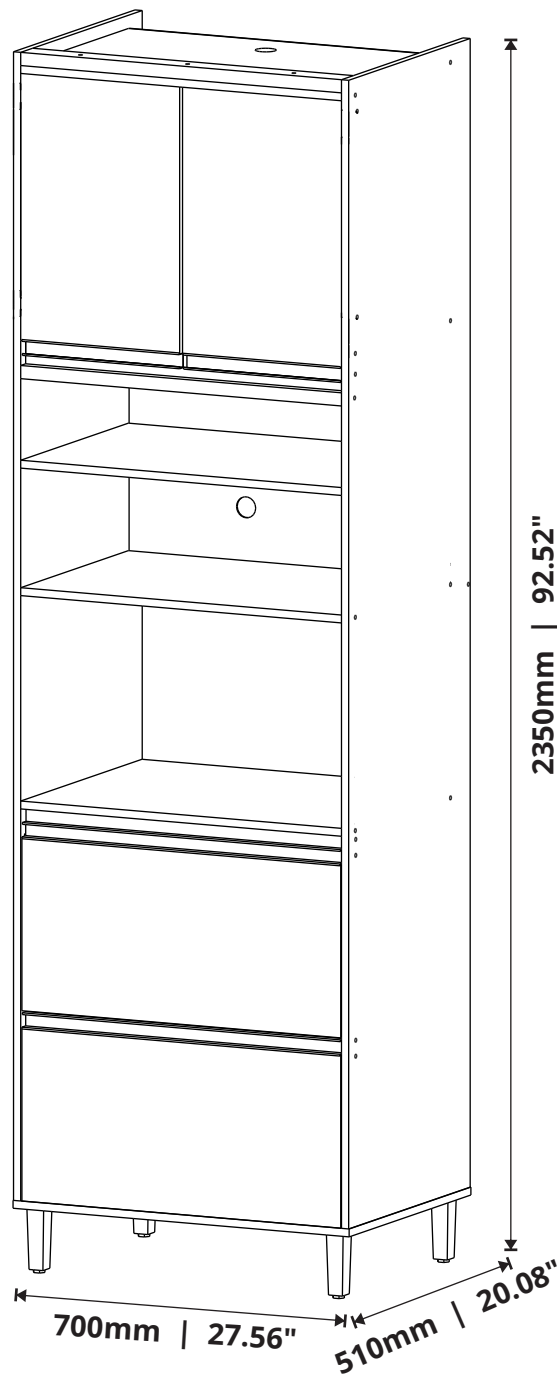

VITAMOV











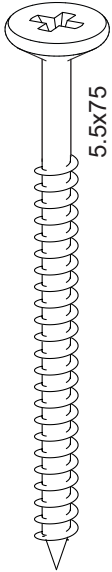
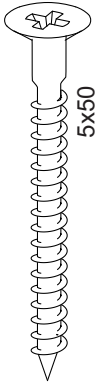
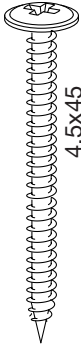

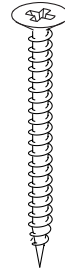

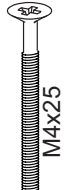

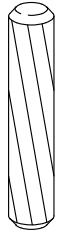
TORRE AGATA AGATA TOWER TORRE AGATA

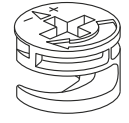
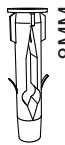
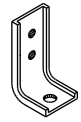
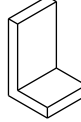

Rua Augusto Zanforlim, 1-25 - Distrito Industrial
CEP: 15520-000, Valentim Gentil/SP - Cx. Postal 18
Fone: (17) 3485-1336
vitamov@vitamov.com.br

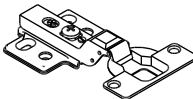
ACESSÓRIOS

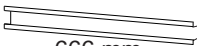
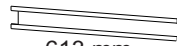
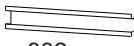
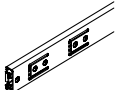
ACCESSORIES - ACCESORIOS

PARAFUSO SCREW TORNILLO	PARAFUSO SCREW TORNILLO	PARAFUSO SCREW TORNILLO	PARAFUSO SCREW TORNILLO	PARAFUSO SCREW TORNILLO	PARAFUSO SCREW TORNILLO	PARAFUSO SCREW TORNILLO	PARAFUSO SCREW TORNILLO	PARAFUSO SCREW TORNILLO	CAVILHA DOWEL TARUGO	PORCA NUT TUERCA	PINO MINIFIX MINIFIX BOLT TORNILLO MINIFIX	CASTANHA MINIFIX MINIFIX CAM CAJA MINIFIX
A 02x	B 34x	C 04x	D 12x	E 03x	F 06x	G 04x	H 62x	I 25x	J 04x	K 12x	L 12x	
												
5.5x75	5x50	4.5x45	3.5x40	3.5x35	3.5x25	M4x25	3.5x14	6x30				12
				BUCHA DE PAREDE WALL PLUG FIXING TACO DE PARED	CANTON. SUP. AÉREO AIR SUP. ANG. BRAC. SOP. ANG. AIRE		CAPA PLAST. PLASTIC COVER CUBIERTA PLAST.	GARRA P/FUNDO BACK JOIN GARRA DE FUNDO	SUPORTE PRAT. SHELF SUPPORT. SOPORTE REPISA			
				M 02x	N 02x	O 02x	P 20x	Q 04x				
												
				8MM								
TAPA FURO CAP TAPA	DOBRAD. SIST. SLOW MOTION 35MM HINGE SLOW MOTION SYSTEM 35MM BISAGRA SIST. SLOW MOTION 35MM		PREGO NAIL CLAVO	PÉS LEGS PIES	PUXADOR HANDLE MANIJA	PUXADOR HANDLE MANIJA	PUXADOR HANDLE MANIJA	COR. TElesc. TElesc. SLIDER COR. TElesc.	GOTA DE SILICONE SILICONE DROP GOTA DE SILICONA			
R 34x	S 04x		T 70x	U 04x	V 02x	W 01x	X 02x	Y 03x	Z 03x			
												
	35 mm		10x10		666 mm	613 mm	332 mm		350			

CAPACIDADE DE CARGA

LOAD CAPACITY - CAPACIDAD DE CARGA

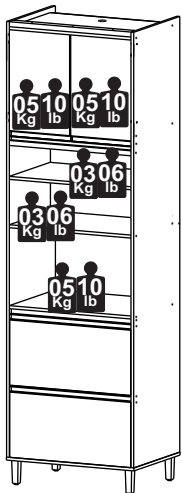

A CAPACIDADE DE CARGA INDICADA É DISTRIBUÍDA NAS ÁREAS DEMONSTRADAS.
THE INDICATED LOAD CAPACITY IS DISTRIBUTED IN THE SHOWN AREAS.
LA CAPACIDAD DE CARGA INDICADA ES DISTRIBUÍDA EN ZONAS DEMONSTRADAS.



AS FERRAMENTAS NECESSÁRIAS PARA A MONTAGEM DO PRODUTO NÃO SÃO FORNECIDAS PELA EMPRESA.
THE TOOLS NEEDED FOR THE PRODUCT ASSEMBLY ARE NOT PROVIDED BY THE COMPANY.
LAS HERRAMIENTAS NECESARIAS PARA LA EL MONTAJE DEL PRODUCTO NO SON PROPORCIONADO POR LA EMPRESA.

CERTIFICADO DE GARANTIA

CERTIFICATE OF WARRANTY - CERTIFICADO DE GARANTÍA

DISPOSIÇÕES

O projeto, instalação e a montagem na residência do consumidor não é responsabilidade da Vitamov. A montagem deve seguir corretamente as instruções que se encontram dentro da embalagem de cada módulo.

A Vitamov se reserva o direito de efetuar modificações de caráter técnico em seus produtos, sem aviso prévio.

EXCLUSÃO DA GARANTIA

O presente termo exclui de sua garantia:

- danos causados em consequência de acidentes, mau uso, manuseio ou deslocamento incorreto dos produtos;
- danos causados por montagem inadequada;
- danos em decorrência de agentes externos (inundações, incêndio, etc);
- defeitos oriundos de umidade excessiva

A fixação dos armários de forma segura e garantida depende da qualidade da parede na qual os mesmos serão instalados.

A Vitamov não se responsabiliza por danos causados por instalações dos armários em paredes inadequadas.

PROVISIONS

The design, installation and assembly in the consumer's home is not the responsibility of Vitamov. Assembly must correctly follow the instructions given found inside the packaging of each module. Vitamov reserves the right to make technical changes to its products without prior notice.

EXCLUSION OF WARRANTY

This term excludes from its warranty:

- damage caused as a result of accidents, misuse, incorrect handling or displacement of the products;
- damage caused by improper assembly;
- damage resulting from external agents (floods, fire, etc.);
- defects from excessive humidity. Fixing the cabinets safely and securely depends on the quality of the wall on which they will be installed. Vitamov is not responsible for damage caused by installing cabinets on inadequate walls.

PROVISIONES

El diseño, instalación y montaje en el domicilio del consumidor no es responsabilidad de Vitamov. El montaje debe seguir correctamente las instrucciones dadas que se encuentra dentro del embalaje de cada módulo. Vitamov se reserva el derecho de realizar cambios técnicos en sus productos sin previo aviso.

EXCLUSIÓN DE GARANTÍA

Este certificado excluye de su garantía:

- daños causados como consecuencia de accidentes, mal uso, manejo incorrecto o desplazamiento de los productos;
- daños causados por un montaje inadecuado;
- daños resultantes de agentes externos (inundaciones, incendios, etc.);
- defectos por exceso de humedad. La fijación de los gabinetes de manera segura y segura depende de la calidad de la pared en la que se instalarán.

Vitamov no es responsable de daños causados por instalar gabinetes en paredes inadecuadas.

PEÇAS

PIECES - PIEZAS

Nº PÇ	PORTUGUÊS	ENGLISH	ESPAÑOL	Medidas/Measures/ Medidas	Qtde.	Cod. Assist.
1	Base	Base	Base	702 x 155 x 15	1	3758
2	Prateleira Central	Center Shelf	Repisa Central	670 x 452 x 15	2	3759
3	Frente Gaveta	Drawer Front	Frente Del Cajón	666 x 329 x 15	2	3774
4	Lateral Gaveta	Drawer Side	Lado Del Cajón	385 x 150 x 15	4	3771
5	Contra Fundo Gaveta	Drawer Counter Bottom	Contra Fondo Del Cajón	646 x 150 x 15	2	3768
6	Contra Fundo Porta Talher	Cutlery Tray Counter Bottom	Contra Fondo Porta Cubiertos	646 x 70 x 15	1	3769
7	Frente Porta Talher	Cutlery Tray Front	Frente Porta Cubiertos	646 x 86 x 15	1	3775
8	Lateral Porta Talher	Cutlery Tray Side	Lado Porta Cubiertos	385 x 70 x 15	2	3770
9	Prateleira Superior	Upper Shelf	Repisa Superior	670 x 432 x 15	1	3761
10	Tampo	Top	Tapa	670 x 452 x 15	1	3760
11	Travessa Traseira	Back Frame	Moldura Trasera	670 x 70 x 15	1	3767
12	Batente	Flap	Solapa	670 x 50 x 15	2	3765
13	Batente Superior	Upper Flap	Solapa Superior	670 x 64 x 15	1	3766
14	Apoio Batente 15mm	Flap Support 15mm	Apoyo Solapa 15mm	670 x 50 x 15	3	3764
15	Porta	Door	Puerta	507 x 332 x 15	2	3778
16	Lateral Direita	Right Side	Lado Derecho	2180 x 510 x 15	1	3750
17	Lateral Esquerda	Left Side	Lado Izquierdo	2180 x 510 x 15	1	3751
18	Apoio Batente 25mm	Flap Support 25mm	Apoyo Solapa 25mm	670 x 50 x 25	2	3762
19	Tampo Encabeçado	Top Frame Top	Moldura Superior	670 x 509 x 24	1	3773
20	Fundo 01	Back Panel 01	Fondo 01	669 x 371 x 3	2	3752
21	Fundo 02	Back Panel 02	Fondo 02	669 x 418 x 3	1	3753
22	Fundo Central c/ Furo	Center Back Panel	Fondo Central c/ Agujero	669 x 503 x 3	1	3754
23	Fundo Superior	Upper Back Panel	Fondo Superior	669 x 480 x 3	1	3756
24	Fundo Gaveta	Back Drawer	Fondo Del Cajón	625 x 395 x 3	3	3757

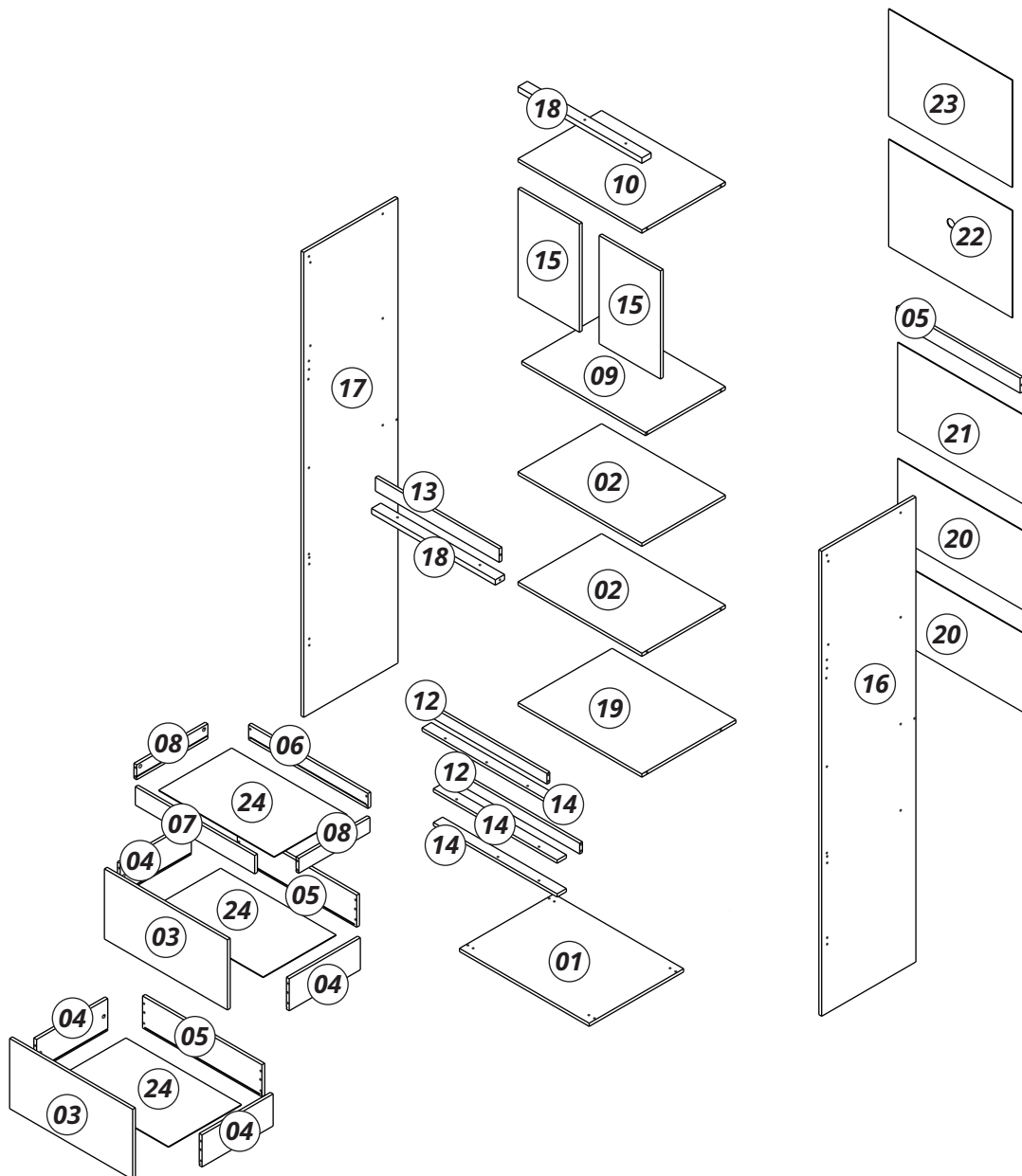

PRÉ-MONTAGEM

PRE ASSEMBLY - PRÉ-MONTAJE

IMPORTANT ATTENTION - IMPORTANTE
 A MONTAGEM DEVE SER REALIZADA POR UM PROFISSIONAL DE MONTAGEM.
 ASSEMBLY MUST BE CARRIED OUT BY AN ASSEMBLY PROFESSIONAL.
 EL MONTAJE DEBE SER HECHO POR UN MONTADOR DE MUEBLES.

1

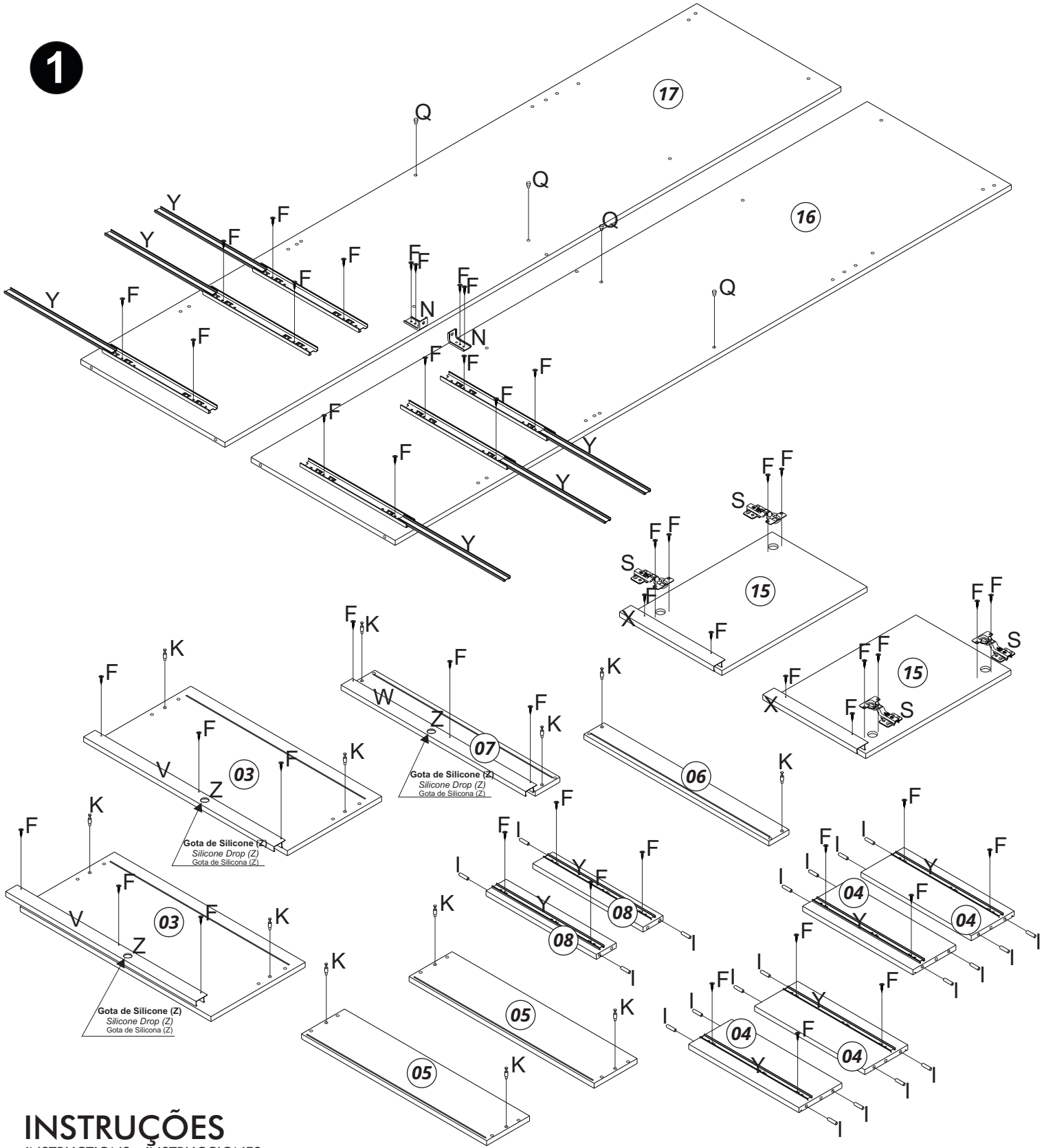

INSTRUÇÕES

INSTRUCTIONS - INSTRUCCIONES

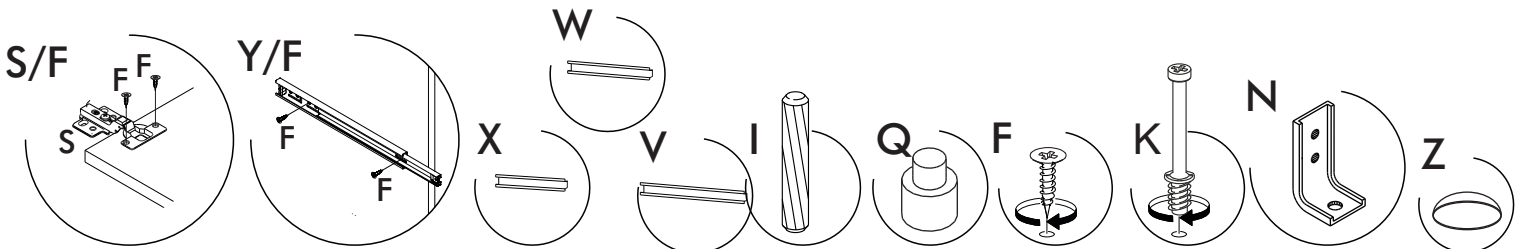

MONTAGEM

ASSEMBLY - MONTAJE

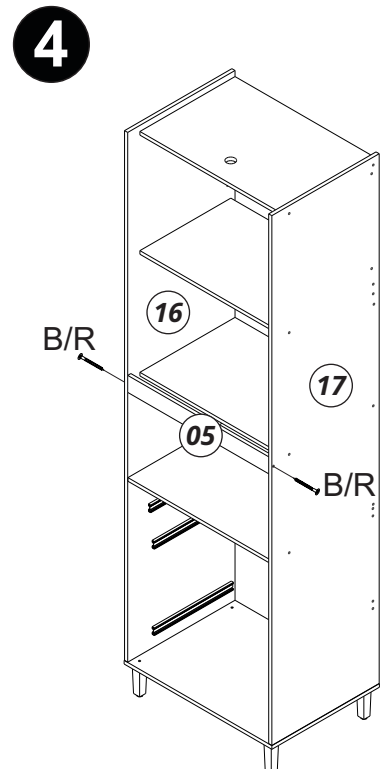
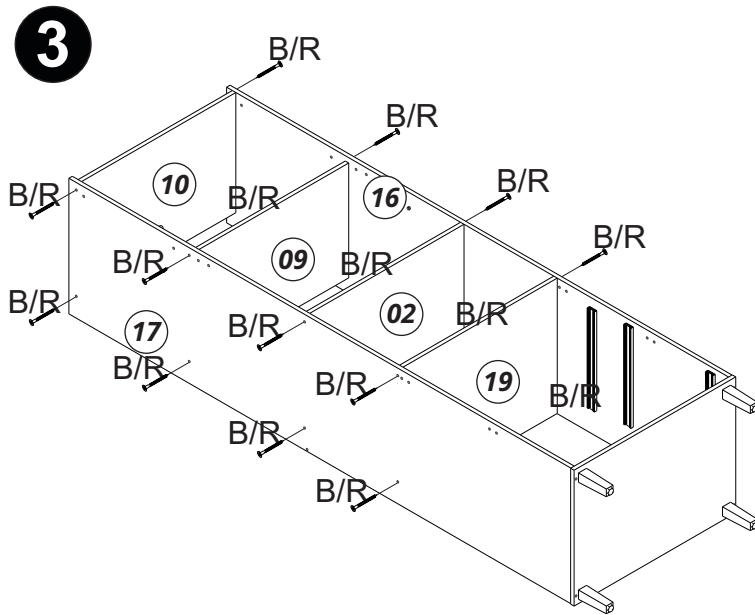
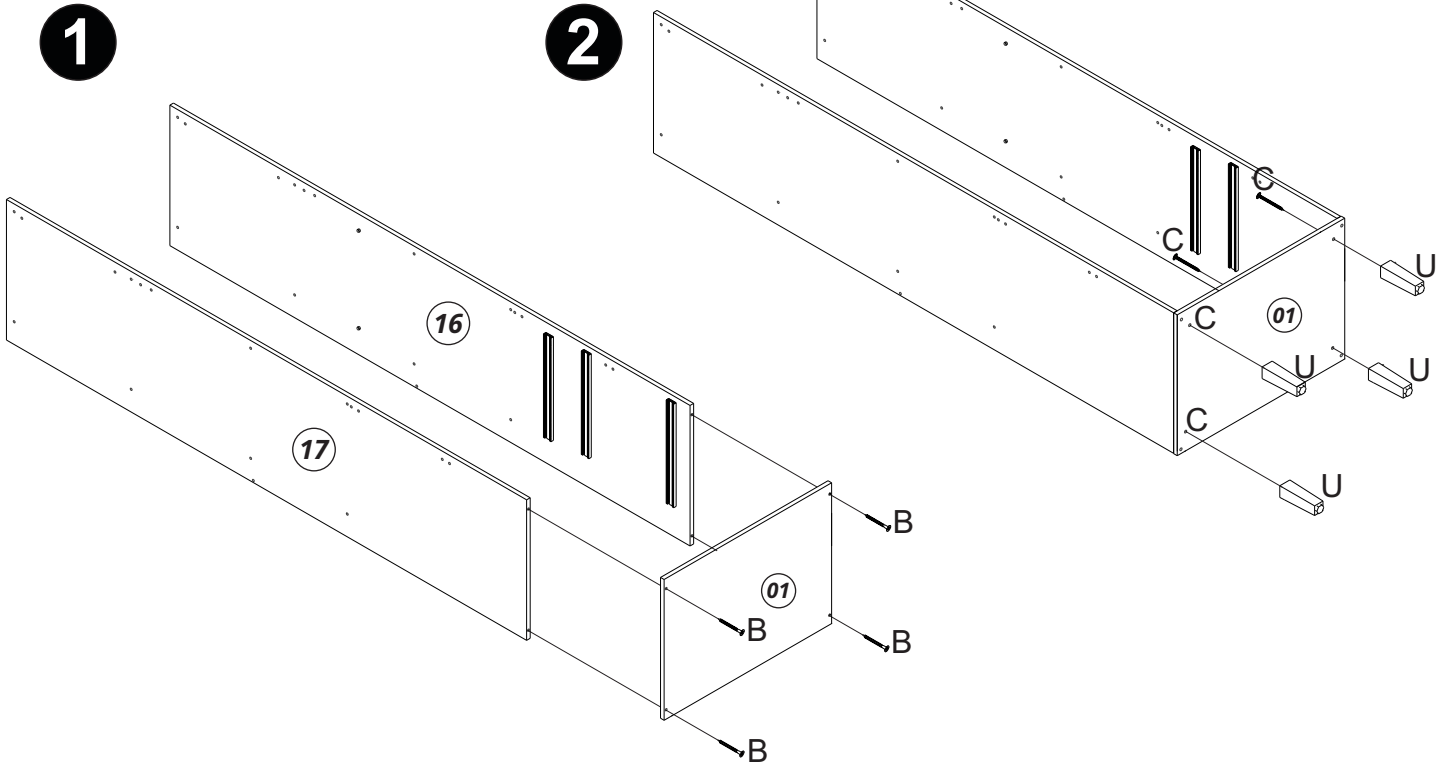

INSTRUÇÕES

INSTRUCTIONS - INSTRUCCIONES

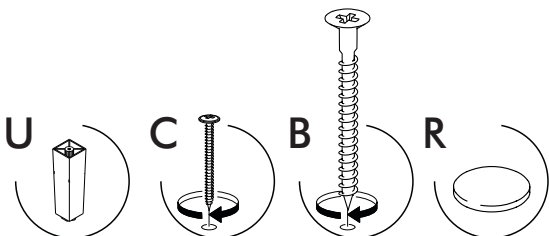

MONTAGEM

ASSEMBLY - MONTAJE

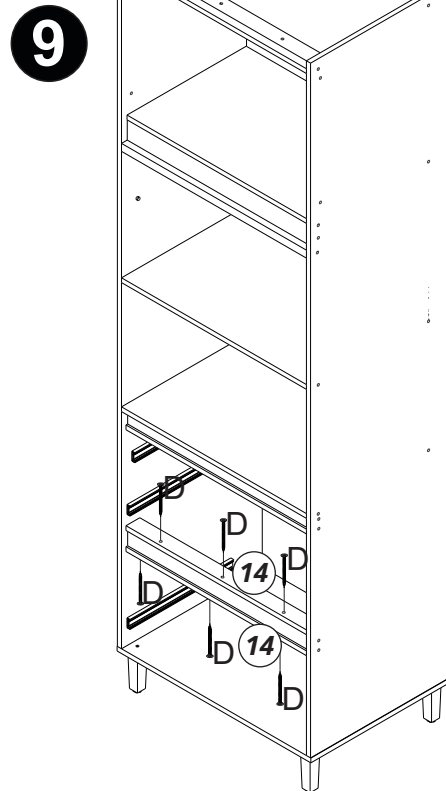
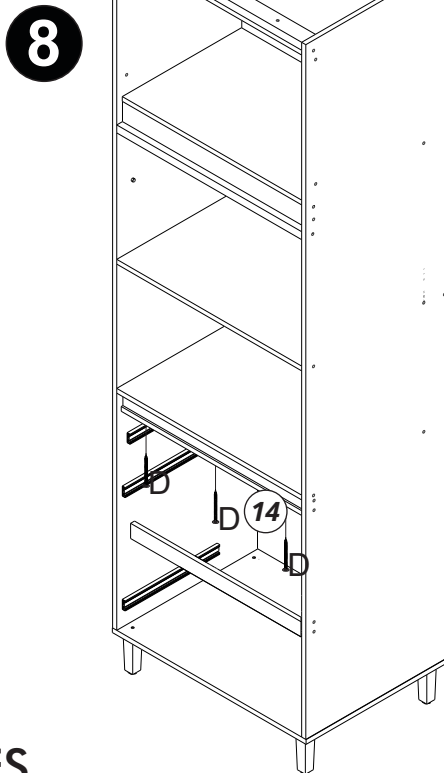
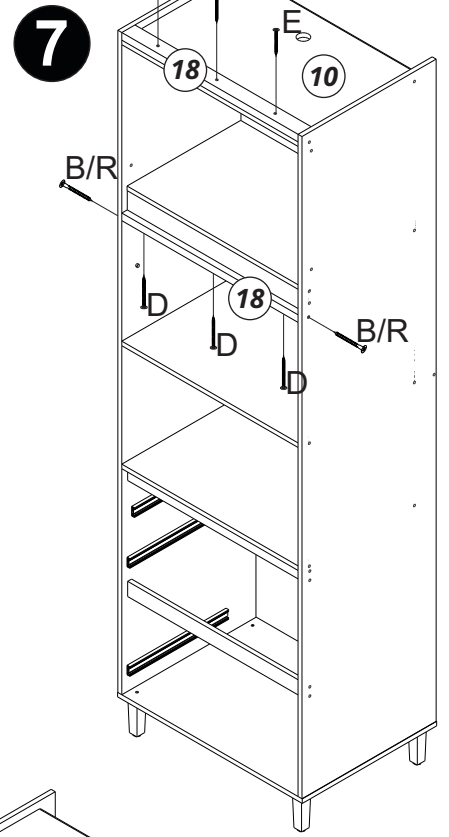
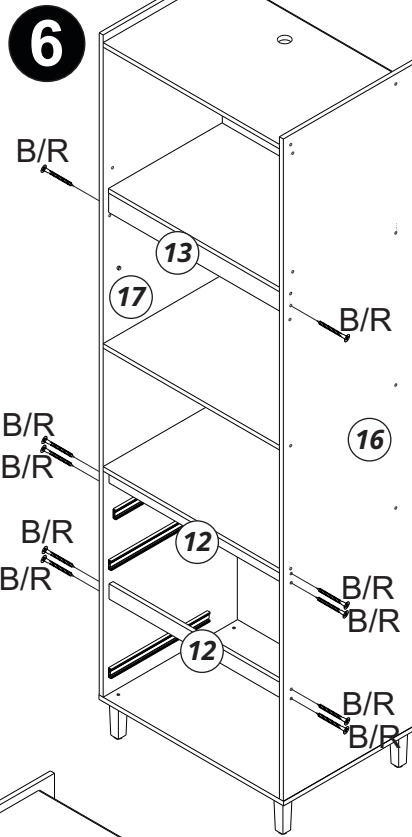
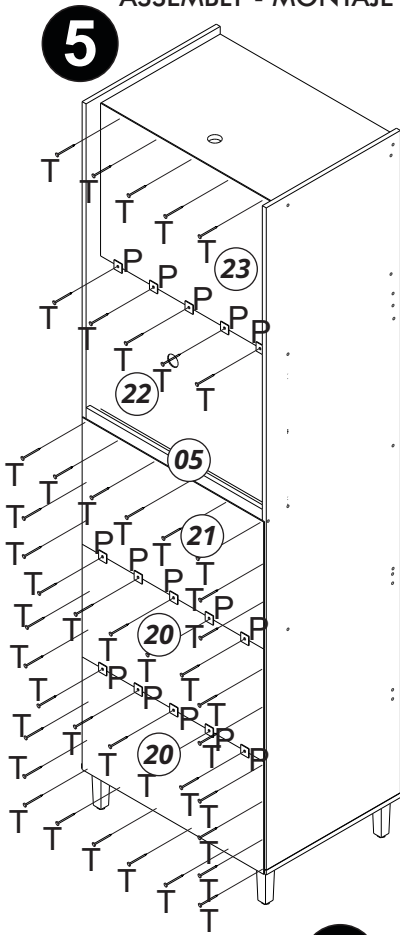

INSTRUÇÕES

INSTRUCTIONS - INSTRUCCIONES

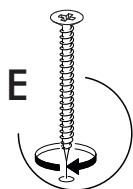
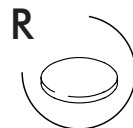
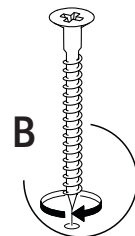
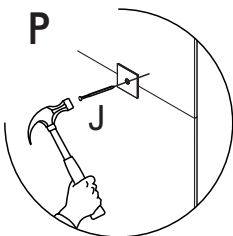
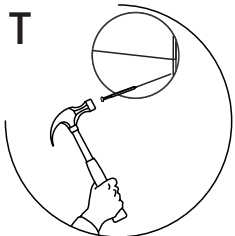

MONTAGEM

ASSEMBLY - MONTAJE

10

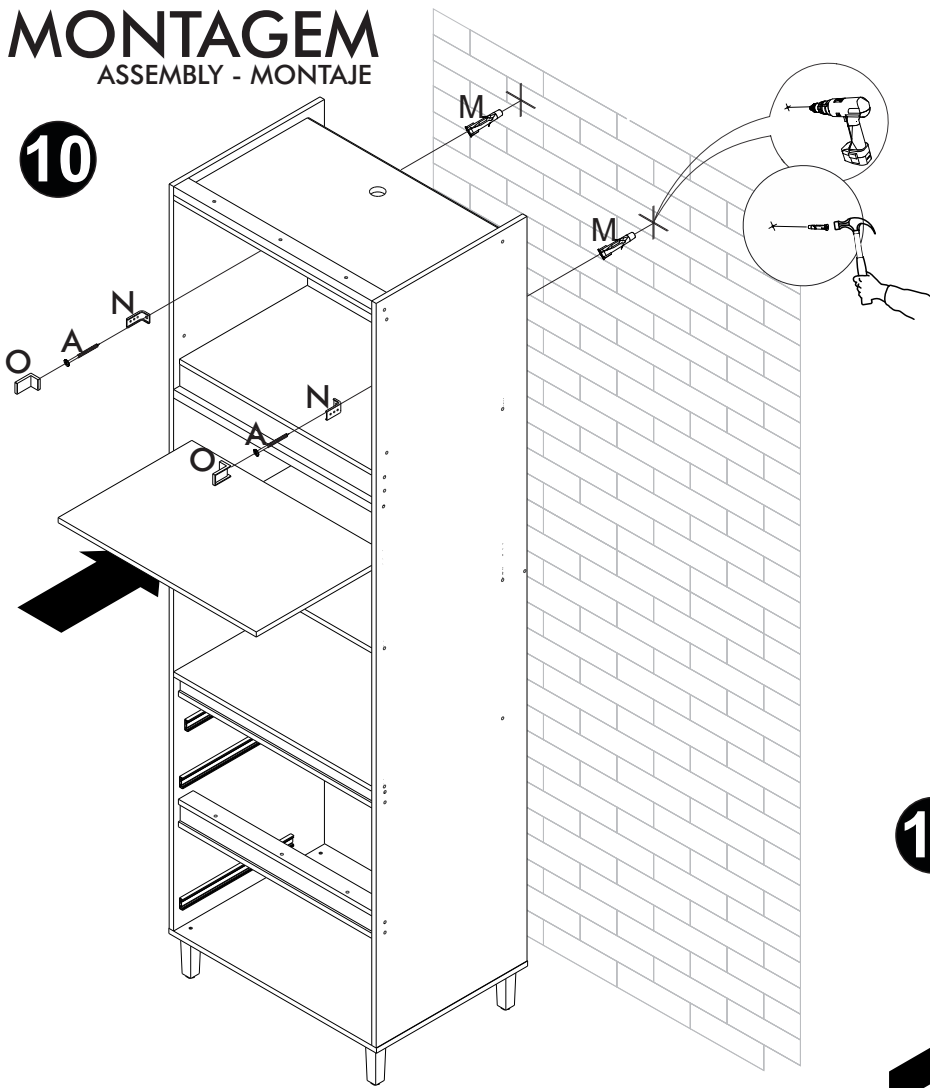

11

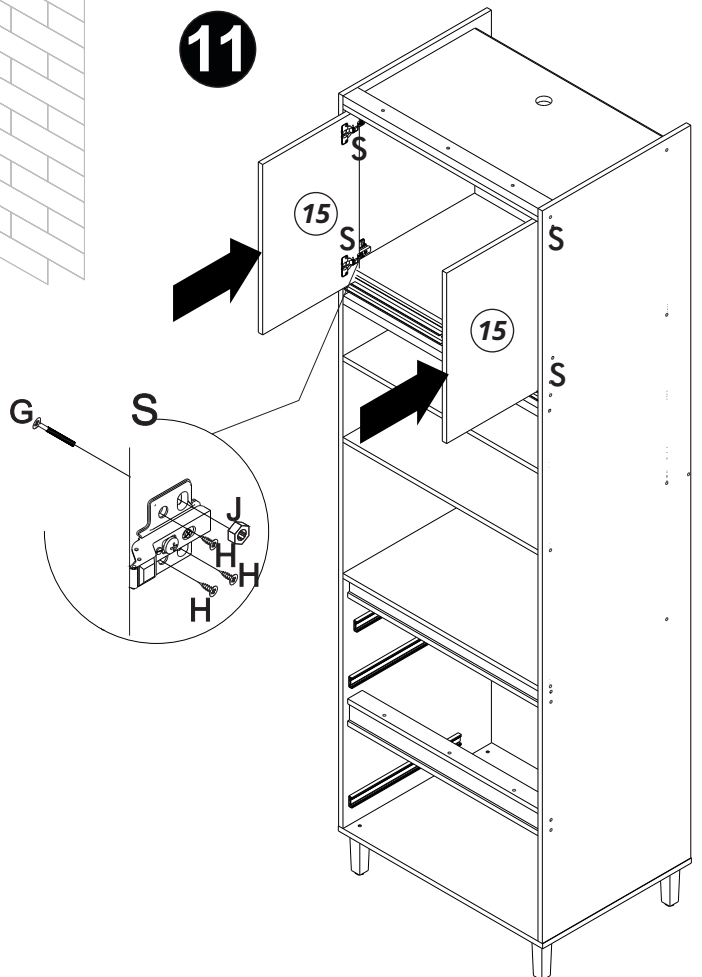

INSTRUÇÕES

INSTRUCTIONS - INSTRUCCIONES

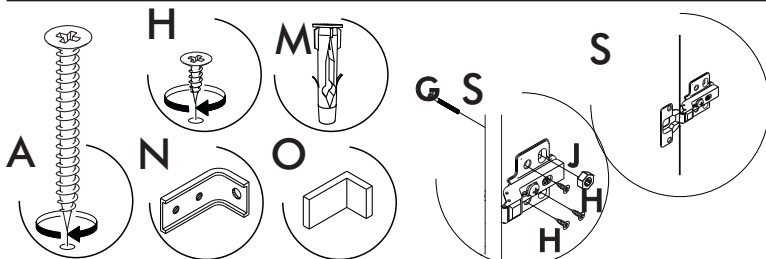

MONTAGEM

ASSEMBLY - MONTAJE

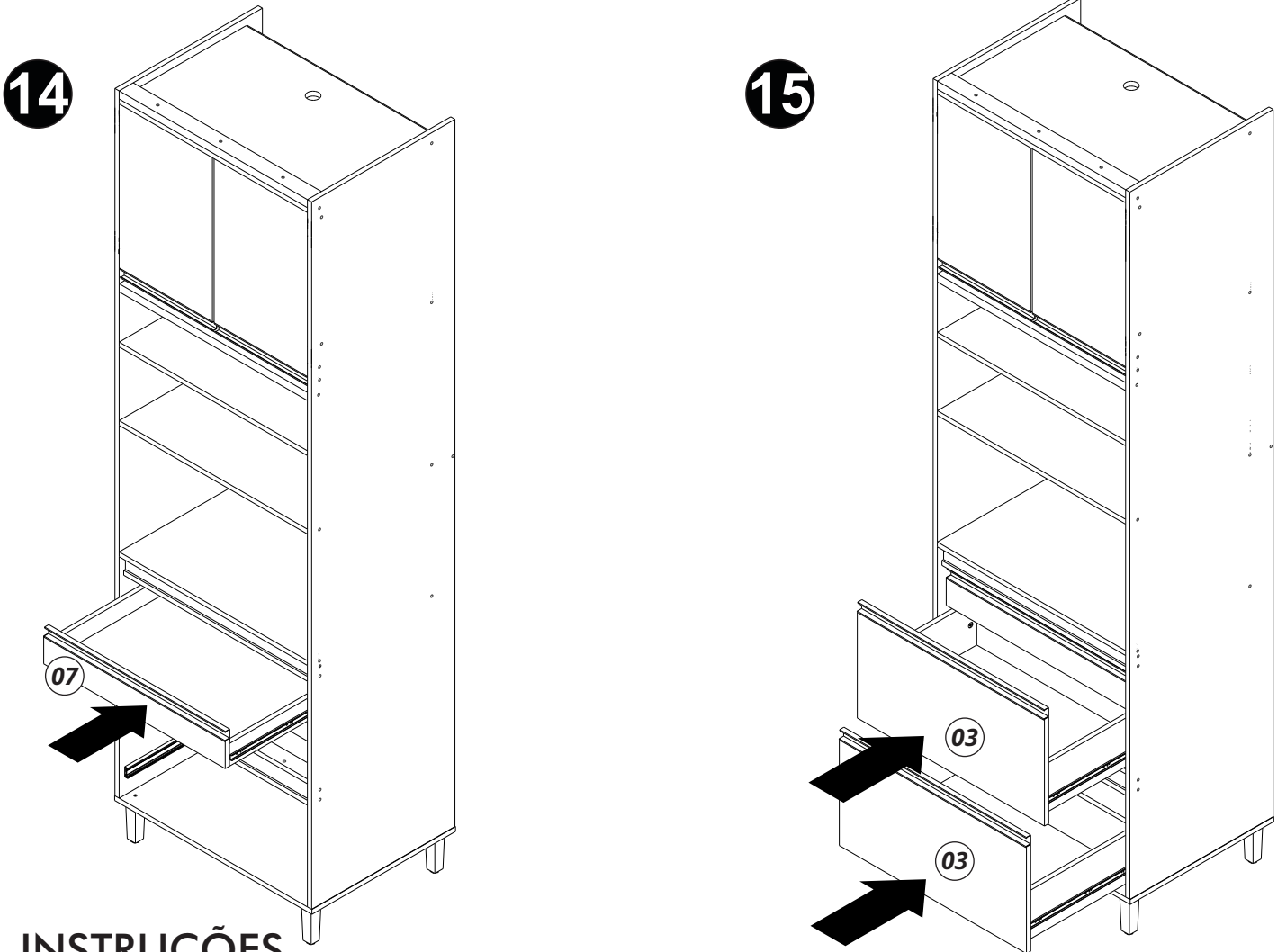
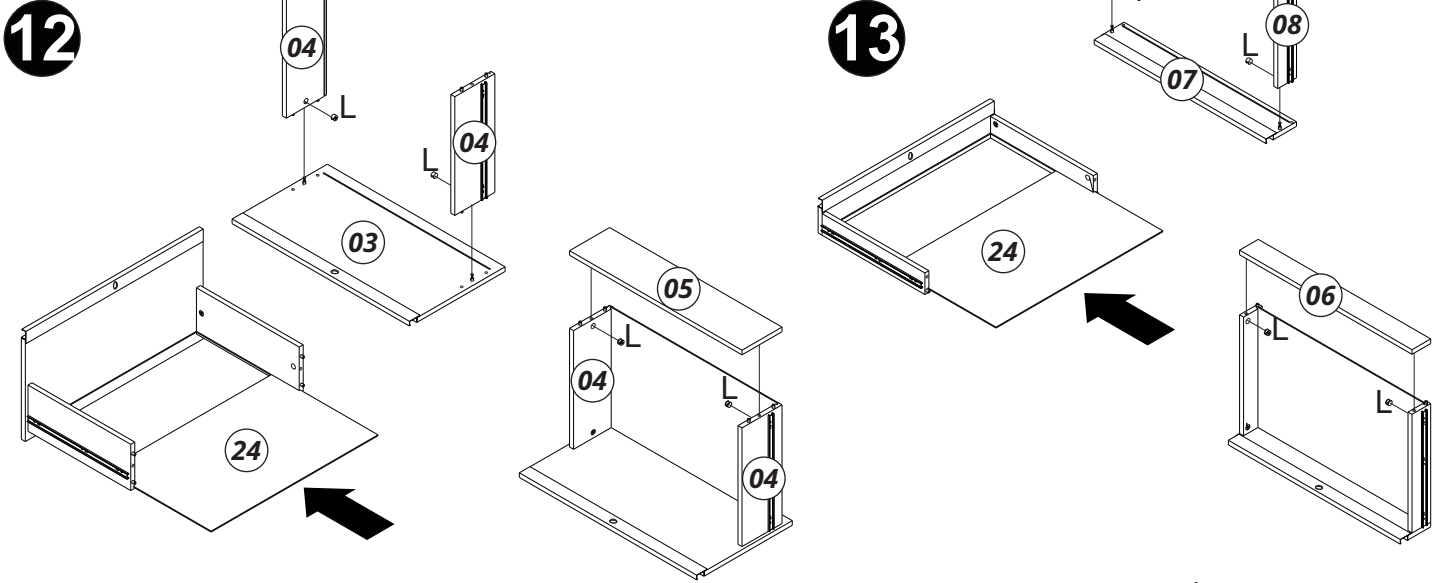

INSTRUÇÕES

INSTRUCTIONS - INSTRUCCIONES

